

U. S. DEPARTMENT OF COMMERCE

Jesse H. Jones, Secretary

CIVIL AERONAUTICS ADMINISTRATION

Donald H. Connolly, Administrator

+

MAINTENANCE, REPAIR, AND ALTERATION
OF CERTIFICATED AIRCRAFT, AIRCRAFT
ENGINES, PROPELLERS, AND INSTRUMENTS



AS AMENDED JUNE 1, 1943

CIVIL AERONAUTICS MANUAL 18

For sale by the Superintendent of Documents, U. S. Government Printing Office, Washington, D. C.

INTRODUCTORY NOTE

This manual contains material interpreting and explaining the maintenance, repair, and alteration requirements specified in the Civil Air Regulations, Part 18.

It should be understood that any method or technique which can be shown to be the equivalent of one set forth in this manual may be acceptable to the Administrator of Civil Aeronautics. Any procedure or method shown to be inapplicable to a particular case may be suitably modified on request. In any event, the acceptance of any equivalent or the modification of any procedure will become effective as of the date of approval rather than the date of its incorporation in this manual. This manual will be revised from time to time as equally acceptable methods or the need for additional explanations are brought to the attention of the Administrator of Civil Aeronautics.

Each section of this manual is arranged and numbered to correspond with the section in the Civil Air Regulations, Part 18, pertaining to the same subject, and the pertinent section of the Civil Air Regulations is quoted ahead of the interpretative material.

On the reverse side of this page will be found a form for convenience in maintaining a record of subsequent revisions. The appendixes to this manual contain general data and information. This information should prove to be particularly helpful to the less experienced agencies.

TABLE OF CONTENTS

		Page
18.1	GENERAL.....	1
18.10	Definitions.....	1
18.2	ROUTINE MAINTENANCE.....	1
18.20	Servicing of aircraft.....	1
18.21	Servicing of aircraft powerplants.....	1
18.22	Servicing of propellers.....	1
18.23	Replacement of small parts.....	1
18.3	REPAIRS.....	2
18.30	Minor repairs.....	2
18.300	Minor aircraft repairs.....	2
18.3000	Nonstructural members.....	2
18.3001	Tanks.....	2
18.3002	Ribs, leading and trailing edges, tip strips.....	2
18.3003	Control cables.....	2
18.3004	Fabric covering.....	2
18.3005	Metal or plywood stressed covering.....	2
18.3006	Replacement of complete components or units.....	2
18.301	Aircraft engine minor repairs.....	3
18.3010	Top overhauls.....	3
18.3011	Complete overhauls.....	3
18.302	Propeller minor repairs.....	3
18.303	Instrument minor repairs.....	3
18.3030	Replacement of removable instruments.....	4
18.31	Major repairs.....	4
18.310	Aircraft major repairs.....	4
18.3100	Ribs and leading edges.....	4
18.3101	Fuel tanks.....	4
18.3102	Fabric covering.....	4
18.3103	Metal or plywood stressed covering.....	4
18.3104	Structural rework involving repair of highly stressed members.....	4
18.311	Aircraft engine major repairs.....	5
18.3110	Overhaul.....	5
18.3111	Special repairs.....	5
18.312	Propeller major repairs.....	5
18.3120	Repairs to wood or metal propellers, propeller hubs, and propeller governors.....	5
18.3121	Repair of steel blades.....	5
18.3122	Repair of steel hubs.....	5
18.3123	Shortening of blades.....	5
18.313	Instrument major repairs.....	5
18.4	ALTERATIONS.....	5
18.40	Minor alterations.....	5
18.400	Aircraft minor alterations.....	5
18.4000	Class III equipment on aircraft specification.....	6
18.4001	Equipment of equal or less weight.....	6
18.4002	Simple modifications.....	6
18.4003	Changes to improve service life.....	6
18.401	Aircraft engine minor alterations.....	6
18.402	Propeller minor alterations.....	6
18.403	Instrument minor alterations.....	6
18.41	Major alterations.....	6
18.410	Aircraft major alterations.....	7
18.4100	Installation or removal of equipment.....	7
18.4101	Design changes.....	7
18.4102	Changes in fuel, oil, cooling, heating, de-icing, and electrical systems.....	7
18.4103	Installation of different type engine, propeller, or feathering system.....	7
18.411	Aircraft engine major alteration.....	7
18.4110	Engine conversion.....	7
18.4111	Modification with unapproved parts.....	8

TABLE OF CONTENTS

	Page	
18.412	Propeller major alterations.....	8
18.413	Instrument major alterations.....	8
18.5	"RULES AND PROCEDURES FOR MAINTENANCE, REPAIRS, AND ALTERATIONS".....	8
18.50	Agencies authorized to perform maintenance, repair, and alteration operations.....	8
18.500	Repair agencies:	
18.5000	Certificated repair station.....	8
18.5001	Manufacturer.....	8
18.5002	Certificated mechanic.....	9
18.501	Agencies authorized to perform maintenance, minor repairs, and minor alterations.....	9
18.5010	Aircraft maintenance, minor repairs, and minor alterations.....	9
18.5011	Aircraft engine maintenance, minor repairs, and minor alterations.....	9
18.5012	Aircraft propeller maintenance, minor repairs, and minor alterations.....	9
18.5013	Aircraft instrument maintenance, minor repairs, and minor alterations.....	9
18.502	Agencies authorized to perform major repairs and major alterations.....	9
18.5020	Aircraft major repairs and major alterations.....	9
18.5021	Aircraft engine major repairs and major alterations.....	10
18.5022	Aircraft propeller major repairs and major alterations.....	10
18.5023	Aircraft instrument major repairs and major alterations.....	10
18.51	Approval of major repairs and major alterations and special privilege provisions for certificated repair stations and manufacturers.....	10
18.52	Flight tests.....	10
18.53	"RECORDING OF REPAIRS AND ALTERATIONS".....	10
18.530	Minor repair and minor alteration log-book entries.....	10
18.5300	Scope of entries.....	10
18.531	Major repair and major alteration records.....	11
18.5310	Number of forms required.....	11
18.5311	Scope of data.....	11
18.5312	Air carrier fleet repairs and alterations.....	11
18.5313	Use of photographs.....	11
18.5314	Proof of strength.....	11
	(a) Comparison with original parts.....	11
	(b) Comparison with manufacturer's drawing.....	12
18.5315	Proof of material conformity.....	12
	(a) Approved material statement.....	12
	(b) Proof by sample or test.....	12
18.5316	Procedures, and guiding comments covering typical alterations.....	12
	(a) The installation of an engine of a type other than that covered by a type (or approved type) certificate.....	12
	(b) The installation of a tail wheel and tire in a previously approved tail skid installation.....	12
	(c) The conversion of an approved type landplane or seaplane to approved ski-plane status.....	12
	(d) Increase in gross weight.....	12
	(e) Change in weight distribution.....	13
	(f) Installation of new items.....	13
	(g) Powerplant changes.....	13
	(h) Control surface changes.....	14
	(i) Fairing, and cowling modifications.....	14
	(j) Appliance installations.....	14
	(k) Batteries.....	14
18.5317	Disposition of data.....	14
	(a) Repairs.....	15
	(b) Alterations.....	15
18.5318	Aircraft operation record entries.....	15
18.5319	Special recording for certificated repair stations, and manufacturers.....	15
18.532	Provision for air carrier records.....	16
18.5320	Repair base records.....	16
18.6	DESIGN, TECHNIQUES, AND MATERIALS.....	16
	A. Materials.....	16
	B. Workmanship.....	16
	C. Technique and practices governing repair and alteration.....	16
18.60	Structures embodying wood, fittings, wires, cables, and fabric.....	16

TABLE OF CONTENTS

	Page	
18.600	Glues and gluing.....	16
18.6000	Grades, and types of glue.....	17
18.6001	Condition of surfaces to be glued.....	17
18.6002	Proper gluing conditions.....	17
18.6003	Gluing pressure.....	17
18.6004	Pressing time and means for applying pressure.....	18
18.601	Wing and control surfaces.....	18
18.6010	General flutter precautions.....	18
18.6011	Splicing of spars.....	18
18.6012	Elongated holes.....	18
18.6013	Longitudinal cracks and local damage.....	18
18.6014	Replacing solid type spars with laminated type.....	19
18.6015	Wing and control surface ribs.....	19
18.6016	Repairs of wood structures at a joint, between joints, at trailing edges, or at spars.....	19
18.6017	Compression ribs.....	19
18.6018	Trailing and leading edges and tip strips.....	19
18.602	Stressed skin plywood covering.....	20
18.6020	General considerations.....	20
18.6021	Extensive damage.....	20
18.6022	Small holes.....	20
18.603	Finishing of wooden structures.....	20
18.604	Fittings.....	20
18.6040	Inspection for defects.....	20
18.6041	Torn, kinked, or cracked fittings.....	20
18.6042	Elongated or worn bolt holes.....	20
18.605	Wire bracing and control cables.....	20
18.6050	Injured, distorted or worn cables.....	20
18.6051	Substitution of cable.....	21
18.6052	Cable terminal splicing or wrapping.....	21
18.6053	Safetying of turnbuckles.....	21
18.606	Fabric covering and finishing.....	21
18.6060	Grade of textile materials.....	21
18.6061	Seams.....	21
18.6062	Covering.....	22
	(a) The envelope method.....	22
	(b) The blanket method.....	22
	(c) Hand sewing or tacking.....	22
	(d) Adequate number of drain grommets.....	22
18.6063	Reinforcing tape.....	22
18.6064	Wing lacing.....	23
18.6065	Fuselage lacing.....	23
18.6066	Finishing tape.....	23
18.6067	Doping.....	23
18.6068	Patching of fabric.....	24
18.6069	Metal fasteners for fabric.....	24
18.61	Welded steel structures.....	25
18.610	General.....	25
18.6100	Preparation for welding.....	25
18.6101	Torch size.....	25
18.6102	Welding rods.....	25
18.6103	Condition of completed weld.....	25
18.6104	Practices to guard against.....	26
18.6105	Cleaning prior to welding.....	26
18.6106	Heat-treating members.....	26
18.6107	Rosette welds.....	26
18.611	Tubular members dented, bent, cracked, or otherwise damaged.....	26
18.6110	Members dented at a station.....	26
18.6111	Members dented, bent, cracked, or otherwise damaged.....	26
18.6112	Repairs at a station or between stations.....	26
18.6113	Special longeron splices.....	27
18.612	Built-in fuselage fittings.....	27
18.6120	Tube of larger diameter than original.....	27

TABLE OF CONTENTS

	Page
18.612 Built-in fuselage fittings—Continued.	
18.6121 Tube of same diameter as original	27
18.6122 Simple sleeve	27
18.6123 Large difference in longeron diameter each side of fitting	27
18.613 Engine mounts	27
18.6130 General considerations	27
18.6131 Check of alinement	28
18.6132 Cause for rejection	28
18.6133 Engine mount ring damage	28
18.614 Landing gears	28
18.6140 Round tube construction	28
18.6141 Streamline tube construction	28
18.6142 Repairable and nonrepairable types of axle assemblies	28
18.6143 Skis	28
18.6144 Ski pedestals	28
18.6145 Floats	29
18.6146 Wheels	29
18.615 Built-up tubular wing or tail surface spans	29
18.616 Wing and tail surface brace struts	29
18.6160 General considerations	29
18.6161 Location of splices	29
18.6162 Fit and alinement	29
18.617 Repairs to joints of arc-welded parts	29
18.6170 Replacing arc-welded joint	29
18.6171 Replacing arc-weld deposit	29
18.618 Steel parts not to be welded	29
18.6180 Brace wires and cables	29
18.6181 Brazed and soldered parts	29
18.6182 Nickel alloy standard parts	30
18.619 Inspection after welding and corrosion protection	30
18.6190 Inspection by magnifying glass	30
18.6191 Inspection by magnetic powder	30
18.6192 X-ray inspection	30
18.6193 Exterior finish	30
18.6194 Interior finish	30
18.62 Stainless steel structures	31
18.620 General considerations	31
18.621 Secondary structural and nonstructural elements	31
18.63 Riveted or bolted steel truss type structures	31
18.630 General considerations	31
18.64 Aluminum and aluminum alloy structures	31
18.640 General considerations and proof of strength	31
18.6400 Unconventional attachments	31
18.6401 Aluminum alloy bolts	31
18.6402 Aluminum alloy nuts	32
18.6403 Self-locking nuts	32
18.6404 Drilling oversize holes	32
18.6405 Disassembly prior to repairing	32
18.6406 Identifying material	32
18.6407 Simple test for identifying heat-treated alloys	32
18.641 Selection of material for replacement parts	33
18.6410 Forming sheet metal parts	33
18.642 Heat treatment	33
18.643 Rivets and riveting practice	33
18.6430 Identification of rivet material	33
18.6431 Rivet size	33
18.6432 Rivet spacing	34
18.6433 Use of A17ST aluminum alloy replacement rivets	34
18.6434 Hollow rivets	34
18.6435 Precautions when riveting	34
18.644 Repair methods	34
18.6440 Splicing of tubes	34
18.6441 Repairs to 24SRT alloy members	34
18.6442 Wing and tail surface ribs	34

TABLE OF CONTENTS

18.644	Repair methods—Continued.	34
18.6443	Patching of small holes.....	34
18.6444	Replacement of portions of skin panels.....	35
18.6445	Splicing of sheets.....	35
18.6446	Straightening of stringers or intermediate frames.....	35
	(a) Members slightly bent.....	35
	(b) Local heating.....	35
18.6447	Splicing of stringers and flanges.....	35
	(a) Size of splicing members.....	35
	(b) Number of rivets in splice.....	35
18.6448	Repairing cracked members.....	36
18.6449	Fittings.....	36
18.645	Fuel tanks and fuel systems.....	36
18.6450	Welded or riveted type tanks.....	36
	(a) Removal of flux after welding.....	36
18.6451	Fuel lines.....	36
18.646	Spot or seam welded structural assemblies.....	37
18.647	Castings.....	37
18.648	Corrosion protection.....	37
18.6480	General considerations.....	37
18.6481	Anodic treatment and priming.....	37
18.6482	Aluminum alloys in contact with wood.....	37
18.6483	Joints between dissimilar metals.....	37
	(a) Bolts and rivets in joints of dissimilar metals or wood.....	38
18.649	Bad practices not considered acceptable.....	38
	(a) Quenching in hot water or air.....	38
	(b) Transferring too slowly from heat-treatment medium to quench tank.....	38
	(c) Reheating at temperatures above boiling water.....	38
	(d) Use of annealed alloys for structural parts.....	38
	(e) Hygroscopic materials improperly moisture-proofed.....	38
	(f) The leaving of any trace of welding flux after welding.....	38
	(g) Use of paint removers.....	38
	(1) Tests for cleaners which are to be used in aqueous solutions.....	38
	(2) Polishes, abrasive cleaners, oily cleaners, etc.....	39
18.65	Safety belt installations.....	39
18.66	Electrical installations.....	39
18.660	Cable insulation.....	39
18.661	Cable terminals.....	39
18.662	Fuse clips.....	39
18.663	Rubber grommets.....	39
18.664	Battery cables.....	40
18.67	Aircraft engines.....	40
18.670	General.....	40
18.6700	Rotating, reciprocating, and highly stressed structural units.....	40
18.671	Crankshafts.....	40
18.672	Replacement parts in certificated aircraft engines.....	40
18.673	Run-in time.....	40
18.674	Cotter pins, wrist-pin retainers, and safety wire.....	40
18.675	Welding in the repair of engines.....	41
18.6750	Structural parts.....	41
18.6751	Secondary parts.....	41
18.676	Metallizing.....	41
18.677	Corrosion prevention.....	41
18.678	Engine accessories.....	41
18.68	Aircraft propellers.....	41
18.680	Hollow and solid steel propellers.....	41
18.6800	Repair of minor damage.....	41
18.681	Aluminum alloy propellers.....	42
18.682	Definition of damaged propellers.....	42
18.6820	Repairable blades.....	42
18.6821	Blades bent in face alinement.....	42
18.6822	Blades bent in edge alinement.....	42
18.6823	Inspection and treatment of defects.....	42
18.6824	Local etching.....	42

TABLE OF CONTENTS

	Page	
18.682	Definition of damaged propellers—Continued.	
18.6825	Treatment of minor surface defects.....	42
	(a) Treatment of metal at edges of defects.....	43
	(b) Treatment of raised edges of scars.....	43
18.6826	Number of defects allowable in blades.....	43
18.6827	Repair of pitted leading edges.....	43
18.6828	Shortening of blades due to defects.....	44
18.683	Causes for rejection.....	44
	(a) Irreparable defects.....	44
	(b) General unserviceability.....	44
	(c) Slag inclusions.....	44
	(d) Transverse cracks.....	44
18.684	Balance.....	44
18.685	Wood propellers.....	44
18.6850	Causes for rejection.....	44
18.6851	Repair of small cracks and cuts.....	44
18.6852	Repair of dents or scars.....	44
18.6853	Use of inlays.....	44
	(a) Materials to be used.....	44
	(b) Preparation of joint.....	45
	(c) Exterior protection of repairs.....	45
	(d) Repairs not to be covered with fabric or stain.....	45
	(e) Direction of grains in inlays.....	45
	(f) Dovetail-type inlays.....	45
	(g) Number of inlays.....	45
18.6854	Hub, neck, and shank repairs.....	45
	(a) Small hub diameter, heavy necks and shanks.....	45
	(b) Small to medium diameter hub with excessively small necks and shanks.....	45
	(c) Large hub diameter, heavy necks and shanks.....	45
18.6855	Blade repairs.....	45
	(a) Exception.....	46
	(b) Trailing edge repairs.....	46
	(c) Repair near hub or tip.....	46
	(d) Repairs at end of metal tipping.....	46
	(e) Repairs under metal tipping.....	46
	(f) Finish.....	46
	(g) Tipping.....	46
	(h) Horizontal and vertical unbalance.....	46
18.686	Propeller hubs.....	46
18.6860	Replacement of small standard parts.....	46
18.6861	General inspection of hubs and clamp rings.....	46
18.6862	Magnetic dust inspection.....	46
18.6863	Finish of hubs and clamp rings.....	47
18.6864	Inspection of splines and cone seats.....	47
18.687	Propeller governors.....	47
18.69	Instruments.....	47
18.690	General.....	47
Fig.	1. Method of splicing solid or laminated rectangular spars.....	48
	2. Method of splicing solid l-spars.....	49
	3. Method of splicing built-up l-spars.....	50
	4. Method of splicing internally routed spars.....	51
	5. Method of splicing box spar flanges (solid block method).....	52
	6. Method of splicing box spar flanges (plate method).....	53
	7. Method of reinforcing a longitudinal crack and/or local damage in a solid or internally routed spar.....	54
	8. Method of splicing box spar webs.....	55
	9. Typical wooden wing rib repairs.....	56
	10. Typical rib splice at a spar.....	57
	11. Typical wing compression rib repairs.....	58
	12. Typical repairs of trailing edges.....	59
	13. Typical methods of repairing elongated or worn bolt holes.....	60
	14. Wrapped or spliced cable terminals.....	61
	15. Fabric attachment (spacing) repair of tears in fabric.....	62
	16. Typical methods of attaching fabric.....	63

TABLE OF CONTENTS

	Page
Fig. 17. Repair of a longeron damaged at a station using a patch plate.....	64
18. Dented, bent, or cracked tube repair in a bay.....	65
19. Alternate tube repair methods.....	66
20. Typical longeron splice using same diameter replacement tube.....	67
21. Engine mount and longeron repair, using larger diameter replacement tube.....	68
22. Alternate typical repairs at a fitting.....	69
23. Streamline tube splice, using round tube (applicable to landing gears).....	70
24. Streamline tube splice, using split sleeve (applicable to wing and tail surface brace struts and other members).....	71
25. Streamline tube splice, using split insert (applicable to landing gears).....	72
26. Streamline tube splice, using plates (applicable to landing gears).....	73
27. Representative types of repairable and nonrepairable axle assemblies.....	74
28. Typical repair method for tubular members of aluminum alloy.....	75
29. Typical repair for buckled or cracked formed metal wing rib capstrips.....	76
30. Typical metal rib repairs (commonly found on small- and medium-size aircraft).....	77
31. Typical repairs of stressed sheet covering.....	78
32. Typical methods of repairing cracked leading and trailing edges and rib intersections.....	79
33. Application of typical flange splices and reinforcement.....	80
34. Typical methods of repairing cracked members at fittings.....	81
35. Typical methods of repairing cracked frame and stiffener combinations.....	82
36. Typical repairs to rudder and to fuselage at tail post.....	83
37. Protractor and method of measuring angle of bend in aluminum alloy propellers.....	84
38. Method of repairing surface cracks, nicks, etc.....	85
39. Correct and incorrect method of reworking leading edge.....	86
40. Repair limits to section width and thickness for aluminum alloy propeller blades.....	87
41. Method of repairing damaged tip.....	88
42. Propeller repair by addition of small inlay.....	89
43. Splicing propeller laminations.....	90
Table 1. Properties of tubes for splices using outside sleeves.....	91
2. Properties of tubes for splices, using inside sleeves.....	91
3. Properties of tubes for splices, using outside sleeves for conditions not covered by tables 1 and 2.....	92
4. Recommended bend radii for 90° bend—in terms of sheet thickness ("T").....	92
5. Rockwell tensile strength relations.....	93
6. Textile materials and supplies used in airplane covering.....	94
Appendix I. Examples and methods of showing compliance with the requirements in case of special repairs involving aluminum alloy structures.....	95
Fig. I. Riveting practice and rivet imperfections.....	99
II. Rivet hole spacing and edge distance.....	100
III. Typical stringer and flange splices.....	101
IV. Example of stringer splice.....	102
V. Example of splice of intermediate frame.....	103
Appendix II. Information on weighing procedure and check of balance for alterations.....	104
Appendix III. Splicing aircraft cable.....	116
Appendix IV. Forms.....	125

MAINTENANCE, REPAIR, AND ALTERATION OF CERTIFICATED AIRCRAFT AND OF AIRCRAFT ENGINES, PROPELLERS, AND INSTRUMENTS

18.1 GENERAL.

"CAR 18.1 General"

18.10 DEFINITIONS.

"CAR 18.10 Definitions. As used in this part:

- "(1) 'Aircraft engine' means an aircraft engine approved by the Administrator.*
- "(2) 'Propeller' means a propeller approved by the Administrator.*
- "(3) 'Instrument' means an instrument installed, for other than purely experimental purposes, in a certificated aircraft.*
- "(4) 'Manufacturer' means (1) the holder of the type certificate, or approval by the Administrator, for an aircraft, aircraft engine, or propeller, or of the current rights, under a licensing arrangement, to the benefits of such type certificate or approval, or (2) the manufacturer of a part or accessory of a certificated aircraft, or (3) the manufacturer of an instrument which is installed in a certificated aircraft: Provided, That such manufacturer shall have in his employ a properly certificated mechanic in direct charge of maintenance, repair, or alteration operations."*

18.2 ROUTINE MAINTENANCE.

"CAR 18.2 Routine maintenance. Routine maintenance is defined as simple or minor preservation operations including, but not limited to, the adjustment of rigging and clearances, and the replacement of small standard parts not involving complex assembly operations."

II. The following are examples of routine maintenance operations:

18.20 SERVICING OF AIRCRAFT.

Servicing on aircraft involving:

- (a) Rigging.
- (b) Adjustment of control surface and control system movements.
- (c) Adjustment of landing gear retracting mechanisms, brakes, de-icing and electrical equipment, etc.

18.21 SERVICING OF AIRCRAFT POWERPLANTS.

Servicing and external adjustments on aircraft powerplants involving:

- (a) Spark plugs.
- (b) Cleaning ignition points.
- (c) Valve tappets.
- (d) Screens, etc.
- (e) Hose connections in fuel, oil, and cooling systems, with identical parts made from same material, etc.

18.22 SERVICING OF PROPELLERS.

Servicing and adjustments of propellers involving:

- (a) Smoothing out surface roughness of blades and polishing of propellers.
- (b) Tightening of loose connections, etc.

18.23 REPLACEMENT OF SMALL PARTS.

Replacement of such small standard parts as:

- (a) Bolts.
- (b) Nuts.
- (c) Pins.
- (d) Bushings.

- (e) Fair-leads.
- (f) Pulleys.
- (g) Turnbuckle terminals.
- (h) Clamps.
- (i) Hose connections in hydraulic systems, etc.
- (j) Batteries, tires, tubes, windshield material, and other similar parts.

18.3 REPAIRS.

"CAR 18.3 Repairs. A repair is any operation other than routine maintenance which is required to restore an aircraft, aircraft engine, propeller, or instrument to a condition for safe operation, including the mending or replacement of damaged or deteriorated parts."

18.30 MINOR REPAIRS.

"CAR 18.30 Minor repairs. Minor repairs are elementary repair operations executed in accordance with standard practices and not within the definition of major repairs."

18.300 MINOR AIRCRAFT REPAIRS.

Repair or replacement work of the following types are considered minor aircraft repairs:

18.3000 NONSTRUCTURAL MEMBERS.

Repairs to nonstructural members which may affect the airworthiness of an aircraft, such as:

- (a) Cowlings.
- (b) Turtlebacks.
- (c) Wing and control surface fairings.
- (d) Electrical installations.
- (e) Windshields.

18.3001 TANKS.

Patching and repairing of leaks in nonintegral fuel, oil, water ballast, hydraulic, and de-icer fluid tanks.

18.3002 RIBS, LEADING AND TRAILING EDGES, TIP STRIPS.

The repair of—

- (a) Not more than two adjacent wing or control surface ribs of a conventional type (wood or metal);
- (b) The leading edge of wing and control surfaces between two adjacent wing or control surface ribs;
- (c) The trailing edge of wings, control surfaces, and flaps, and
- (d) The wing and control surface tip strips.

18.3003 CONTROL CABLES.

Replacement of control cables.

18.3004 FABRIC COVERING.

- (a) Patching of fabric.
- (b) Replacement of the fabric covering of surfaces involving an area not greater than required to repair two adjacent ribs.

18.3005 METAL OR PLYWOOD STRESSED COVERING.

The patching of holes in metal or plywood stressed covering not to exceed 3 inches in any direction when ribs, stringers, bulkheads, and reinforcements are not directly affected.

18.3006 REPLACEMENT OF COMPLETE COMPONENTS OR UNITS.

Replacement of complete components or units such as listed below with parts supplied by the original manufacturer or manufactured in accordance with approved drawings.

- (a) Wings.¹
- (b) Replaceable wing tips.¹
- (c) Control surfaces.¹
- (d) Wing or control surface bracing (struts or wires).
- (e) Sea wings.
- (f) Floats.
- (g) Wheels.
- (h) Skis.
- (i) Landing gears.
- (j) Tail wheel assemblies.
- (k) Engine mounts (prefabricated and bolted on, not to be welded on).
- (l) Fuel and oil system accessories.
- (m) Power-plant cowling.
- (n) Intake or exhaust systems.
- (o) Fuel and oil tanks.
- (p) Power-plant controls.
- (q) Propeller controls.
- (r) Instruments and safety belts.

18.301 AIRCRAFT ENGINE MINOR REPAIRS.

1. Overhaul work of the following types are considered aircraft engine minor repairs:

18.3010 TOP OVERHAULS.

Top overhauls of engines of less than 200 horsepower involving the following:

- (a) Removal of cylinders.
- (b) Grinding valves and removing carbon.
- (c) Fitting new rings.
- (d) Adjustment of valve gear or replacement of parts in valve mechanism except the rotating parts in the crankcase.

18.3011 COMPLETE OVERHAULS.

Complete overhauls of engines of less than 200 horsepower involving only the adjustment, cleaning, fitting, and replacement of parts with identical parts produced by the original manufacturer or parts specifically approved by the Civil Aeronautics Administration.

18.302 PROPELLER MINOR REPAIRS.

1. Repairs to wood or metal propellers, propeller hubs, and propeller governors when made in accordance with the repair practices and methods prescribed in this manual, or in accordance with "Administrator of Civil Aeronautics Approved" recommendations of the propeller manufacturers are considered minor propeller repairs.

18.303 INSTRUMENT MINOR REPAIRS.

1. Cleaning, adjustment, or replacement of parts in instruments such as are listed below are considered minor instrument repairs.

- (a) Air-speed indicators.
- (b) Altimeters.
- (c) Rate of climb indicators.
- (d) Compasses.
- (e) Turn and bank indicators.
- (f) Engine tachometers.
- (g) Temperature and pressure gages.
- (h) Fuel flow meters.
- (i) Electrical and gyroscopic instruments.

¹ After completing replacements of wings, wing tips, and control surfaces, the airplane must be test-flown prior to returning it to service.

18.3030 REPLACEMENT OF REMOVABLE INSTRUMENTS.

Replacement of removable instruments may be considered an aircraft minor repair in accordance with section 18.300.

18.31 MAJOR REPAIRS.

"CAR 18.31 Major repairs. Major repairs are complex repair operations of vital importance to the airworthiness of an aircraft, including but not limited to:

"(a) Straightening, splicing, welding and similar operations when the strength of important structural members might be appreciably affected thereby.

"(b) Operations requiring complicated or unconventional techniques or equipment."

18.310 AIRCRAFT MAJOR REPAIRS.²

1. Repairs of structural components and elements of components such as outlined below usually found necessary as the result of an accident, or of unforeseen conditions requiring repair or reinforcement are considered to be major aircraft repairs, unless classified as minor aircraft repairs in the preceding section (sec. 18.300).

18.3100 RIBS AND LEADING EDGES.

Repair of three or more wing or control surface ribs or the leading edge of wings and control surfaces between such ribs.

18.3101 FUEL TANKS.

Rebuilding including rebottoming of standard type or integral fuel tanks.

18.3102 FABRIC COVERING.

- (a) Repair of fabric covering involving a greater area than required to repair two adjacent ribs. (See sec. 18.204.)
- (b) Replacement of fabric on fabric-covered components such as: wings, fuselages, control surfaces, etc.

18.3103 METAL OR PLYWOOD STRESSED COVERING.

- (a) The repair of damaged areas in metal or plywood stressed covering exceeding three inches in any direction.
- (b) The repair of portions of skin sheets by making additional seams.
- (c) Splicing of skin sheets.

18.3104 STRUCTURAL REWORK INVOLVING REPAIR OF HIGHLY STRESSED MEMBERS.

All repairs involving the replacing, strengthening, reinforcing, and splicing of highly stressed members such as:

- (a) Spars.
- (b) Spar flanges.
- (c) Members of truss-type beams.
- (d) Thin sheet webs of beams.
- (e) Keel and chine members of boat hulls or floats.
- (f) Corrugated sheet compression members which act as flange material of wings or tail surfaces.
- (g) Wing main ribs and compression members.
- (h) Wing or tail surface brace struts.
- (i) Fuselage longerons;
- (j) Members of the side truss, horizontal truss, or bulkheads;
- (k) Main seat support braces and brackets;
- (l) Landing gear brace struts;

² See CAR 18.51 Provision for Approval of Major Repairs and Major Alterations.

- (m) Axles;
- (n) Wheels;
- (o) Skis, and ski pedestals; and
- (p) Parts of the control system such as control columns, pedals, shafts, or horns.

18.311 AIRCRAFT ENGINE MAJOR REPAIRS.

1. Work of the following types is considered aircraft engine major repair:

18.3110 OVERHAUL.

Top and complete overhaul of engines of 200 horsepower or more.

18.3111 SPECIAL REPAIRS.

Repairs to engine parts by welding or any other means. (See CAM 18.6 for technique and practices.)

18.312 PROPELLER MAJOR REPAIRS.

1. Repairs of the following types are considered major propeller repairs:

18.3120 REPAIRS TO WOOD OR METAL PROPELLERS, PROPELLER HUBS, AND PROPELLER GOVERNORS.

Repairs to wood or metal propellers, propeller hubs, and propeller governors not made in accordance with repair practices and methods as prescribed in this manual or in accordance with "Administrator of Civil Aeronautics Approved" recommendations of the propeller manufacturer.

18.3121 REPAIR OF STEEL BLADES.

The repair or straightening of steel blades.

18.3122 REPAIR OF STEEL HUBS.

The repair or machining of steel hubs.

18.3123 SHORTENING OF BLADES.

The shortening of blades below the minimum diameter indicated in the Civil Aeronautics Administration Propeller Specifications so as to materially affect the performance of the propeller.

18.313 INSTRUMENT MAJOR REPAIRS.

1. No attempt is made at present to differentiate between minor and major instrument repairs, and therefore all instrument repairs may be considered minor repairs.

18.4 ALTERATIONS.

"CAR 18.4 Alterations. An alteration is any appreciable change in the design of an aircraft, aircraft engine, propeller, or instrument."

18.40 MINOR ALTERATIONS.

"CAR 18.40 Minor alterations. A minor alteration is:

- "(a) An alteration having no appreciable effect on the weight, balance, structural strength, powerplant operation, flight characteristics, or other characteristics affecting the airworthiness of an aircraft; or
- "(b) An alteration for which specific plans and instructions have been approved by the Administrator and which can be executed by means of elementary operations."

18.400 AIRCRAFT MINOR ALTERATIONS.

1. Changes such as listed below are considered minor aircraft alterations. (See Appendix II, Weighing Procedure and Check of Balance, for details of equipment classifications.)

18.4000 CLASS III EQUIPMENT ON AIRCRAFT SPECIFICATION.

The installation or removal of specific items of effective Class III equipment listed in the Aircraft Specification ³ when made in accordance with the manufacturer's instructions.⁴

18.4001 EQUIPMENT OF EQUAL OR LESS WEIGHT.

The installation or removal of equipment of equal or less weight and in the same location and in the same manner as that listed as Class III equipment in the Aircraft Specification.

18.4002 SIMPLE MODIFICATIONS.

Changes of relatively minor nature, such as the addition of reinforcements or fittings which are easily installed and the installation of which does not require appreciable rework of the aircraft structure and when made in compliance with "Airworthiness Maintenance Inspection Notes" which supplement the Aircraft Specifications ³ issued by the Civil Aeronautics Administration, or in accordance with "Administrator of Civil Aeronautics Approved" alteration instructions of the manufacturer of the aircraft.⁵

18.4003 CHANGES TO IMPROVE SERVICE LIFE.

Changes on structural and nonstructural elements of a minor nature for the purpose of improving the service life or reducing maintenance costs, provided the cumulative weight changes of such alterations do not exceed 1 percent of the certificated weight empty since the last Civil Aeronautics Administration inspection and the empty weight center of gravity location is not changed.

18.401 AIRCRAFT ENGINE MINOR ALTERATIONS.

1. The alteration or conversion of an aircraft engine by replacement or addition of parts, in compliance with "Airworthiness Maintenance Inspection Notes" listed on the engine specifications issued by the Civil Aeronautics Administration, or in accordance with "Administrator of Civil Aeronautics Approved" alteration instructions of the manufacturer of the aircraft engine, is considered a minor aircraft engine alteration.

18.402 PROPELLER MINOR ALTERATIONS.

1. Changes on propellers, hubs, or propeller governors made in compliance with "Airworthiness Maintenance Inspection Notes" which supplement the Propeller Specifications issued by the Civil Aeronautics Administration, or in accordance with "Administrator of Civil Aeronautics Approved" alteration instructions of the propeller manufacturer, are considered minor propeller alterations.

18.403 INSTRUMENT MINOR ALTERATIONS.

1. Design changes made in accordance with the "Administrator of Civil Aeronautics Approved" recommendations of the manufacturer of the instruments are considered minor instrument alterations.

18.41 MAJOR ALTERATIONS.

"CAR 18.41 Major alterations. Major alterations are all alterations not within the definition of minor alterations."

³ Copies of Aircraft Specifications may be obtained from Chief, Correspondence Section, Civil Aeronautics Administration, Washington, D. C.

⁴ The cumulative weight changes of all such alterations since the last Civil Aeronautics Administration inspection should not exceed 1 percent of the certificated weight empty.

⁵ Proper reference to the pertinent request by the Civil Aeronautics Administration or alteration bulletin of the manufacturer should always be made in the repair records of the repair agency and in the aircraft logbook for the benefit of the Inspector of the Civil Aeronautics Administration conducting the follow-up inspection.

18.410 AIRCRAFT MAJOR ALTERATIONS.

1. Changes of the following type when not listed as Class III equipment in the Aircraft Specifications are considered major aircraft alterations because they are likely to affect the airworthiness of an aircraft to a great degree. (See Appendix II, Weighing Procedure and Check of Balance, for details of equipment classifications.)

18.4100 INSTALLATION OR REMOVAL OF EQUIPMENT.⁶

The installation or removal of equipment of any type and in any location other than outlined in section CAM 18.400.

18.4101 DESIGN CHANGES.

Basic design changes on any component such as:

- (a) Wings.
- (b) Tail surfaces.
- (c) Fuselage.
- (d) Landing gear, etc.
- (e) Elements of components (spars, ribs, shock absorbers, bracing, cowlings, turtlebacks, fairings, balance weights, etc.) of an aircraft.

18.4102 CHANGES IN FUEL, OIL, COOLING, HEATING, DE-ICING, AND ELECTRICAL SYSTEMS.

Changes over the *original design* in the fuel, oil, cooling, heating, de-icing, electrical, and exhaust systems of an aircraft. This includes conversions of any sort for the purpose of using fuel of rating or grade other than that called for in *original approval*.

18.4103 INSTALLATION OF DIFFERENT TYPE ENGINE, PROPELLER, OR FEATHERING SYSTEM.

The installation of a type of engine or propeller different from that approved for the airplane or the installation of propeller feathering or de-icing systems.

18.411 AIRCRAFT ENGINE MAJOR ALTERATION.

1. Changes of the following type are considered major aircraft engine alterations:

18.4110 ENGINE CONVERSION.

Conversion of an aircraft engine from one approved type to another, involving any changes in compression ratio, propeller gear, or impeller gear ratios, which requires extensive rework and testing of the engine, though all the work may be accomplished by using factory parts and carried out in accordance with the aircraft engine manufacturer's "Administrator of Civil Aeronautics Approved" alteration instructions.

⁶ In case such work is carried out so that:

- (a) The cumulative weight change of all such alterations since the last Civil Aeronautics Administration inspection does not exceed 1 percent of the certificated weight empty.
- (b) The cumulative effect upon the empty weight center of gravity of all such alterations since the last Civil Aeronautics Administration inspection does not exceed 1/2 of 1 percent of the M. A. C.
- (c) The method of attachment to the structure is such as to distribute the weight uniformly over as large a portion of the structure as practical.
- (d) The installation is such as to have no adverse effect upon the original airworthiness. (For instance, equipment increasing the fire hazard or otherwise interfering with the safe operation of an aircraft should not be considered satisfactory for installation.)

Such alterations are considered to fall under the special privilege provisions for certificated repair stations and manufacturers contained in CAR 18.51 without having to be executed in accordance with any other manual or further specification approved by the Administrator.

18.4111 MODIFICATION WITH UNAPPROVED PARTS.

When aircraft engine structural parts are replaced with parts other than those supplied by the original manufacturer or specifically approved by the Civil Aeronautics Administration⁷ for the purpose of obtaining approval of the new parts.

18.412 PROPELLER MAJOR ALTERATIONS.

1. Changes in blade design, hub, or propeller governor not authorized on the Propeller Specifications issued by the Civil Aeronautics Administration⁸ are considered major propeller alterations.

18.413 INSTRUMENT MAJOR ALTERATIONS.

1. Changes in design not made in accordance with the "Administrator of Civil Aeronautics Approved" recommendations of the instrument manufacturer are considered major instrument alterations.

18.5 "RULES AND PROCEDURES FOR MAINTENANCE, REPAIRS, AND ALTERATIONS."**18.50 AGENCIES AUTHORIZED TO PERFORM MAINTENANCE, REPAIR, AND ALTERATION OPERATIONS.**

"CAR 18.50 Agencies authorized to perform maintenance, repair, and alteration operations. Maintenance, repair, and alteration operations shall be performed only by: (1) A certificated mechanic having the proper rating or a person working under the direct supervision of such mechanic; or (2) a certificated repair station having the proper rating; or (3) the manufacturer of the aircraft or part of the aircraft to be repaired: Provided, That all instrument repairs and alterations and propeller major repairs and major alterations shall be performed only by a certificated repair station having the proper rating or by the instrument or propeller manufacturer."

18.500 REPAIR AGENCIES.

Agencies which repair or alter an aircraft, aircraft engine, propeller, or appliance in accordance with the classifications set forth in sections 18.3 and 18.4 of this manual are classified as:

- (a) Certificated repair stations.
- (b) Manufacturers.
- (c) Certificated mechanics.

18.5000 CERTIFICATED REPAIR STATION.

A certificated repair station means a repair station certificated in accordance with the provisions of the Civil Air Regulations (CAR 52).

18.5001 MANUFACTURER.

For the purpose of this manual a manufacturer means (1) the holder of the type certificate, or approval by the Administrator, for an aircraft, aircraft engine, or propeller, or of the current rights, under a licensing arrangement, to the benefits of such type certificate or approval; or (2) the manufacturer of a part or accessory of a certificated aircraft; or (3) the manufacturer of an instrument which is installed in a certificated aircraft: *Provided*, That such manufacturer shall have in his employ a properly certificated mechanic⁹ in direct charge of maintenance, repair, or alteration operations.

⁷ Changes as above require extensive proof tests as specified in Part 13 of the Civil Air Regulations and CAM 13. Also see section 18.672 of this manual.

⁸ Changes such as outlined above usually involve proof testing of the propeller or governor in accordance with CAR 14.

⁹ See CAR 24.23 Factory mechanic rating.

18.5002 CERTIFICATED MECHANIC.

A certificated mechanic means a mechanic certificated in accordance with the provisions of the Civil Air Regulations (CAR 24).

18.501 AGENCIES AUTHORIZED TO PERFORM MAINTENANCE, MINOR REPAIRS, AND MINOR ALTERATIONS.**18.5010 AIRCRAFT MAINTENANCE, MINOR REPAIRS, AND MINOR ALTERATIONS.**

Maintenance, minor repairs, or minor alterations of a certificated aircraft must be made by one of the following:

- (a) A certificated repair station holding the appropriate rating.
- (b) The manufacturer of the aircraft.
- (c) A certificated mechanic holding an aircraft mechanic rating.
- (d) A person under the direct supervision of a certificated mechanic holding an aircraft mechanic rating.

18.5011 AIRCRAFT ENGINE MAINTENANCE, MINOR REPAIRS, AND MINOR ALTERATIONS.

Maintenance, minor repairs, or minor alterations of a certificated aircraft engine must be made by one of the following:

- (a) A certificated repair station holding the appropriate rating.
- (b) The manufacturer of the aircraft engine.
- (c) A certificated mechanic holding an aircraft engine mechanic rating.
- (d) A person under the direct supervision of a certificated mechanic holding an aircraft engine mechanic rating.

18.5012 AIRCRAFT PROPELLER MAINTENANCE, MINOR REPAIRS, AND MINOR ALTERATIONS.

Maintenance, minor repairs, or minor alterations of a certificated propeller must be made by one of the following:

- (a) A certificated repair station holding the appropriate rating.
- (b) The manufacturer of the propeller.
- (c) A certificated mechanic holding an aircraft engine mechanic rating.
- (d) A person under the direct supervision of a certificated mechanic holding an aircraft engine mechanic rating.

18.5013 AIRCRAFT INSTRUMENT MAINTENANCE, MINOR REPAIRS,¹⁰ AND MINOR ALTERATIONS.

Maintenance, minor repairs, or minor alterations of an instrument must be made by one of the following:

- (a) A certificated repair station holding the appropriate rating.
- (b) The manufacturer of the instrument.

18.502 AGENCIES AUTHORIZED TO PERFORM MAJOR REPAIRS AND MAJOR ALTERATIONS.**18.5020 AIRCRAFT MAJOR REPAIRS AND MAJOR ALTERATIONS.**

Major repairs or major alterations of a certificated aircraft must be made by one of the following:

- (a) A certificated repair station holding the appropriate rating.
- (b) The manufacturer of the aircraft.
- (c) A certificated mechanic holding an aircraft mechanic rating.
- (d) A person under the direct supervision of a certificated mechanic holding an aircraft mechanic rating.

¹⁰ Replacement of removable instruments may be considered an aircraft minor repair (see sec. 18.3006) and may be made or supervised by a certificated mechanic.

18.5021 AIRCRAFT ENGINE MAJOR REPAIRS AND MAJOR ALTERATIONS.

Major repairs or major alterations of a certificated aircraft engine must be made by one of the following:

- (a) A certificated repair station holding the appropriate rating.
- (b) The manufacturer of the aircraft engine.
- (c) A certificated mechanic holding an aircraft engine mechanic rating.
- (d) A person under the direct supervision of a certificated mechanic holding an aircraft engine mechanic rating.

18.5022 AIRCRAFT PROPELLER MAJOR REPAIRS AND MAJOR ALTERATIONS.

Major repairs or major alterations of a certificated propeller must be made by one of the following:

- (a) A certificated repair station holding the appropriate rating.
- (b) The manufacturer of the propeller.

18.5023 AIRCRAFT INSTRUMENT MAJOR REPAIRS AND MAJOR ALTERATIONS.

Major repairs or major alterations of an instrument must be made by one of the following:

- (a) A certificated repair station holding the appropriate rating.
- (b) The manufacturer of the instrument.

18.51 APPROVAL OF MAJOR REPAIRS AND MAJOR ALTERATIONS AND SPECIAL PRIVILEGE PROVISIONS FOR CERTIFICATED REPAIR STATIONS AND MANUFACTURERS.

"CAR 18.51 Provision for approval of major repairs and major alterations. No aircraft, aircraft engine, or propeller which has undergone any major repair or major alteration shall be returned to service until examined, inspected, and approved by a duly authorized representative for the Administrator unless such repair or alteration has been executed in accordance with a manual or specification approved by the Administrator² and performed by a certificated repair station of the proper rating or by the manufacturer."

² "Such manual or specification may, for example, be issued by the manufacturer, a certificated repair station, or by the Administrator. All such manuals or specifications issued by parties other than the Administrator must be approved by him."

18.52 FLIGHT TESTS.

"CAR 18.52 Flight tests. When an aircraft or aircraft engine or propeller thereof has undergone a maintenance, minor repair, or minor alteration operation which may have changed its flight characteristics appreciably or substantially affected its operation in flight, or has undergone a major repair or major alteration, such aircraft shall, prior to carrying passengers, be test flown by a pilot having at least 200 solo hours and holding at least a private pilot certificate and appropriate rating for the aircraft to be test flown."

18.53 "RECORDING OF REPAIRS AND ALTERATIONS."

18.530 MINOR REPAIR AND MINOR ALTERATION LOGBOOK ENTRIES.

"CAR 18.530 Minor repair and minor alteration logbook entries. An adequate description of every minor repair or minor alteration of an aircraft, aircraft engine, or propeller shall be entered in the appropriate logbook over the signature and certificate number of the mechanic directly in charge of or performing such repair or alteration; and in case a manufacturer or a certificated repair station makes said repair or alteration, the appropriate logbook shall also be signed by an authorized official of such agency. The installation of an instrument in an aircraft shall be recorded in the aircraft logbook by the agency making the installation."

18.5300 SCOPE OF ENTRIES.

In case the work was performed in compliance with a request of the Civil Aeronautics Administration or in accordance with recommendations of the manufacturer of the unit repaired, or if replacement of a component purchased from the original manufacturer was involved, the entry should so state.

18.531 MAJOR REPAIR AND MAJOR ALTERATION RECORDS.

"CAR 18.531 Major repair and major alteration records. A repair agency performing a major repair or major alteration on an aircraft, aircraft engine, or propeller shall execute such Repair and Alteration Forms as may be prescribed and furnished by the Administrator and shall deliver a duplicate copy of any such Form to the owner of the aircraft and make proper entries on the appropriate page of the Aircraft Operation Record."

18.5310 NUMBER OF FORMS REQUIRED.

The Repair and Alteration Form ¹¹ should be submitted in duplicate unless the inspector of the Civil Aeronautics Administration requests additional copies. One copy of these forms should be kept by the owner of the aircraft, and the original should be given to the inspector. In cases where an air carrier is operating under the provisions of AO-23, the inspector will determine that the proper entries are made in the pertinent weight record and that the effects of the weight changes have been accounted for. In all other cases the inspector will ascertain that the proper loading schedule notations, overlays, or revised schedules have been prepared and submitted, if applicable.

18.5311 SCOPE OF DATA.

The Repair and Alteration Form should incorporate such technical data as are necessary to substantiate the airworthiness of the repair or alteration, either by reference to the figures and tables of this manual or by incorporating in the Form pertinent stress analyses, weight and balance computations, test reports, drawings, well-dimensioned detail sketches or photographs. When these data are extensive, they should be appended to the original copy of such form, which is given to the inspector of the Civil Aeronautics Administration and referred to in both copies of the Form.

18.5312 AIR CARRIER FLEET REPAIRS AND ALTERATIONS.

In the case of simultaneous repairs or alterations being completed on several aircraft of an air carrier, only one complete file need be submitted. The Repair and Alteration Form should contain the identification marks and serial numbers of all aircraft affected. If additional aircraft of the same fleet are subsequently similarly repaired or altered, the Repair and Alteration Forms for these aircraft need merely refer to the previously submitted file by identification mark, serial number, and date. The inspector will also determine that the operator has a reliable method of recording cumulative weight changes.

18.5313 USE OF PHOTOGRAPHS.

Photographs, accompanied by detail descriptions of the work performed and the materials used and identified on these photographs, may be substituted for the usual sketches required on the Repair and Alteration Form. In this manner it is possible to record the original or damaged structure before any work on the structure is attempted and then record the various steps of the repair and alteration as the work progresses to final completion.

18.5314 PROOF OF STRENGTH.

(a) *Comparison with original parts.* The original parts removed from an aircraft in making a major repair or alteration should be retained by the repair agency until the inspector has completed his examination of the work for conformity or, in the case of a repair, satisfies himself that the repaired structure is airworthy.

¹¹ See appendix IV-1.

- (b) *Comparison with manufacturer's drawing.* The inspector of the Civil Aeronautics Administration may at his discretion require that he be furnished drawings from the original manufacturer of the part or parts in question. To obtain the necessary drawings, the repair agency should inform the manufacturer of the serial number of the airplane and the extent of the damage. Upon completion of the work, the drawings and executed Repair and Alteration Form, together with a copy of the manufacturer's letter of transmittal, should be presented to the inspector to aid him in his inspection. In the letter of transmittal the manufacturer should list the drawings and specify the serial number of the airplane for which they were issued. When it can be shown that factory drawings are not obtainable, as in the case when the manufacturer is out of business and has no active successor, the repair agency may obtain photostats of such drawings from a Washington blueprinting firm at regular rates, through the Chief, Aircraft Airworthiness Section of the Civil Aeronautics Administration, Washington, D. C.

18.5315 PROOF OF MATERIAL CONFORMITY.

- (a) *Approved material statement.* A statement by the repair agency to the effect that the parts or materials used in the work have been purchased in accordance with approved specifications from the original manufacturer or a reputable aircraft supply firm will be required. Equally acceptable are invoices issued by the original manufacturer or his authorized agent.
- (b) *Proof by sample or test.* The inspector of the Civil Aeronautics Administration, at his discretion, may require that he be furnished with samples of the materials used in making the major repair or alteration. When it is not possible to compare the materials by a visual inspection or simple tests such as taking Rockwell or Brinell hardness readings, the results of material specification tests of the original and replacement samples should be supplied.

18.5316 PROCEDURES AND GUIDING COMMENTS COVERING TYPICAL ALTERATIONS.

Detail procedures to be followed covering typical major alterations, such as the following cases (a), (b), and (c), will be found in CAM 04.0611 through 04.06131.

- (a) *The installation of an engine of a type other than that covered by a type (or approved type) certificate.*
- (b) *The installation of a tail wheel and tire in a previously approved tail skid installation.*
- (c) *The conversion of an approved type landplane or seaplane to approved ski-plane status.*
- (d) *Increase in gross weight.* An increase in the gross weight will naturally require that the structure be able to withstand greater loads in flying and landing. There is usually involved, therefore, a study of the original design data and the preparation of a partial strength analysis, preferably by the manufacturer of the airplane. Likewise, the flying characteristics will be affected, so flight tests are usually required. Increases in weight are often accompanied by changes in weight distribution, the effects of which are covered in item (e). Increases in gross weight for specific industrial purposes, such as crop dusting, may be permitted, but the aircraft will be restricted to that type of operation and will be given an NR identification

mark. Contact an inspector of the Civil Aeronautics Administration when an aircraft is to be used in restricted operations.

- (e) *Change in weight distribution.* Any change in the location of items having considerable weight or the addition of new items (equipment, etc.) may have serious effects on the flight behavior of an airplane. When any changes in weight distribution are made, it is the repair agency's responsibility to determine, by computation or reweighing, whether or not the approved limits, which appear on the airplane specification in the case of later models, will be exceeded. If they are, approval cannot be granted unless it can be proved by a flight test that all flight requirements are complied with.

It is of the greatest importance to realize that flight characteristics not only become worse gradually with rearward displacement of the center of gravity, but that a condition sometimes exists or will finally be reached where a *small change will have very large effects*. For this reason great care should be taken not to increase the weight of the airplane to the rear of the wing beyond that which was originally approved. Decreasing the weight carried forward of the wing, such as using a lighter propeller, will have a similar effect. Increasing the weight forward of the wing will tend to disturb the balancing in flight and might make the landing conditions dangerous. Naturally, the effects of weight changes will be greater nearer the nose and the tail. Reasonably small changes within the portion covered by the wing are not usually serious from a balancing or stability standpoint. For details regarding weight and balance procedure, see appendix II of this manual.

- (f) *Installation of new items.* In addition to the effects on weight and weight distribution discussed in items (d) and (e), there is a danger that a piece of new equipment, if improperly installed, will cause local loads which might seriously damage the airplane structure. It should be remembered that in flight maneuvers and in landing it is possible to develop inertia forces such that an item will impose a load of several times its own weight on the supporting structure. For instance, a 35-pound storage battery supported by a fuselage cross tube will have an effective weight of considerably over 100 pounds in hard landing. If the cross tube was not originally designed for this load, it will probably fail or bend. The greatest danger arises when such a partial failure occurs in landing, without being noticed, as the structure might then fail completely during some subsequent flight.

- (g) *Powerplant changes.* The powerplant installation on a certificated aircraft has been thoroughly checked in accordance with rules based on a study of accident and service records covering several years of operation of all types of aircraft. These records show that many accidents are due to improper installation in *small details* concerning the fuel or oil system, cowling, manifolding, and items of a like nature. It is, therefore, unwise to make any changes without careful consideration.

When changes appear to be necessary in the powerplant installation, the manufacturer of the aircraft had best be consulted. If the manufacturer has no data concerning such a change, an inspector of the Civil Aeronautics Administration should be consulted to

determine if the airworthiness of the airplane will be adversely affected by making the change.

With reference to propeller changes, the placard accompanying the certificate states the type of propeller which it is safe to use. A larger diameter propeller should not be used without investigation, because it may result in unsatisfactory ground clearance with resultant excessive wear on the tips. Furthermore, a change to a propeller of appreciably different diameter, either larger or smaller, or different pitch, might in some cases result in unsafe performance.

- (h) *Control surface changes.* Any change in the size of control surfaces affects the loading conditions for the airplane structure and therefore requires additional strength analyses, static tests, or both. Flight tests are usually required also. The owner is particularly warned against making minor changes on control surfaces, since the original design often just meets certain requirements for flutter prevention. No *balancing weights* should be removed or added without consulting the manufacturer and finally obtaining the inspector's approval. In particular, it is essential that nothing be done to alter the contour of the nose section ahead of the hinge line or to increase the weight of movable surfaces to the rear of the hinge line. Balancing and trimming tabs have very powerful effects and should not be altered or allowed to become loose. *All these precautions against flutter become increasingly important as the speed of the airplane is increased.* On high-speed airplanes any change of the control surfaces or system may result in flutter or dangerous vibration.
- (i) *Fairing and cowling modifications.* Although changes in fairing can usually be made without impairing the airworthiness of the aircraft, it has been found that certain airplanes are very sensitive to slight changes in body lines, windshield designs, and filleting. Obviously, any change in engine cowling affects the cooling and thereby introduces possibilities of malfunctioning or failure of the engine.
- Low wing airplanes are usually supplied with wing-fuselage fillets which prevent tail buffeting. Any alteration of such fillets may be dangerous. The manufacturer should best be consulted regarding such changes.
- (j) *Appliance installations.* The aircraft and appliance manufacturer's instructions for installation of equipment should be closely followed. In particular, the recoil from flares should be provided for and, in the case of position lights, where certain angular limits are required, the light manufacturer's mounting instructions should be followed.
- (k) *Batteries.* Batteries should be installed in accordance with the instructions contained in Civil Air Regulations 04.5821. It should be noted that dry batteries are not considered satisfactory for the operation of position lights.

18.5317 DISPOSITION OF DATA.

The repair agency should request an inspector of the Civil Aeronautics Administration to examine the work, the technical data, and the executed forms. In order to enable the inspector to examine the work, it will generally be necessary to contact him while the work is in progress or arrange to have sufficient inspection openings in order that he may accomplish this inspection after completion of the work. Welds, particularly in the primary structure, should not be painted over until after the inspection unless the inspector's

permission is obtained. Careful consideration of the following check lists will eliminate many questions and the attendant delays.

(a) Repairs.

1. Are the new parts made of the same material as the replaced parts? Is a stronger material used? Does the Repair and Alteration Form clearly state these facts?
2. Are the new parts exact duplicates of the originals (as regards dimensions, fillets, welds, etc.)? Does the Repair and Alteration Form so state? If there are deviations, are they *'all* listed and are all necessary new dimensions given?
3. Does the Repair and Alteration Form state whether or not the original part was heat-treated? Does the Repair and Alteration Form state whether or not the new (re-repaired) part is similarly heat-treated (or reheat-treated)?
4. Is there any weight change? Does the Repair and Alteration Form state definitely one way or the other?

The above-mentioned items can usually be answered quickly by the man doing the work on the airplane, but their omission is very common.

(b) Alterations.

1. How much does the article installed (or removed) weigh?
2. What is the location of the removed or installed item? This should be given in inches from a datum.
3. Has the balance of the airplane been substantiated for the alteration?
4. How is the new item attached? Is the attachment shown in the sketches?
5. Is the new item adequately described; i. e., are the manufacturer and model noted?
6. If the new item is a structural alteration or involves attachment by means of additional structure, are all necessary dimensions and other engineering information given? Has the strength of the structure been adequately substantiated or shown to be obviously satisfactory?

18.5318 AIRCRAFT OPERATION RECORD ENTRIES.

A repair agency engaged in the major repair or major alteration of an aircraft, aircraft engine, or propeller should also make an entry descriptive of the work done on the appropriate page of the Aircraft Operation Record. (See appendix IV-2 for sample entry and CAR 18.532 for air-carrier aircraft recording). It is urged that in all questionable repair or alteration cases, which might involve new repair methods, flight characteristics, or complicated questions of weight and balance, the executed forms, together with all data, be submitted to the branch offices of the Aircraft Airworthiness Section of the Civil Aeronautics Administration for approval of the questionable points prior to final completion of the work.

18.5319 SPECIAL RECORDING FOR CERTIFICATED REPAIR STATIONS AND MANUFACTURERS.

In order to maintain the records of all work done on aircraft under the special-privilege provision contained in CAR 18.51, certificated repair stations (other than those working on certificated air-carrier aircraft) and manufacturers should adhere to the following procedure:

- (a) Supply the owner of the repaired or altered aircraft with a copy of the Civil Aeronautics Administration's Repair and Alteration Form and

append to it all details such as drawings, balance investigations, or weight records, as the case may be.

- (b) Make the necessary revisions to the pertinent page of the Aircraft Operations Record. (See appendix IV for sample entry.)

18.532 PROVISION FOR AIR-CARRIER RECORDS.

"CAR 18.532 Provision for air-carrier records. Logbook and Aircraft Operation Record entries required in this part may be replaced, in the case of repairs or alterations to scheduled air-carrier aircraft, by a suitable system of recording repairs, alterations, and signatures of responsible personnel."

18.5320 REPAIR BASE RECORDS.

The special procedures outlined in section CAM 18.5318 need not be followed by repair stations or certificated air carriers repairing or altering air-carrier aircraft. The repair base records, including the weight-control records maintained by these agencies, are interpreted to serve the identical purpose.

18.6 DESIGN, TECHNIQUES, AND MATERIALS.

"CAR 18.6 Design, techniques, and materials. Repairs shall be so executed, and materials of such strength and quality shall be used that the condition of the repaired aircraft, aircraft engine, propeller, or instrument shall be at least equivalent to its original or a properly altered condition in regard to aerodynamic and mechanical function, structural strength, and resistance to vibration and deterioration, and all other qualities affecting airworthiness. Alterations shall be so designed and executed that the altered aircraft, aircraft engine, propeller, or instrument will comply with the airworthiness requirements in effect when the particular model of the aircraft or part of the aircraft was originally certificated and, in addition, with particular provisions of the current airworthiness requirements rendered necessary for safe operation by the alteration."

A. *Materials.* All materials must be of at least the same quality, physical properties, and heat treatment as were used in the original construction of the unit being repaired or altered. Materials conforming to the specifications of the U. S. Army or Navy and SAE are considered satisfactory. When specifying the physical properties of materials, it is important that minimum specification values be used rather than "typical or average" values.

B. *Workmanship.* Workmanship should be of sufficiently high grade to insure the proper continued functioning of the repaired or altered unit. Tolerances should be closely checked in order that the original structure is accurately reproduced. Metal sheet and tubing gages usually conform to well-established specifications. Tolerances on machined parts are based on general practice and vary from about plus or minus 0.010 inch to values necessary to secure interchangeability of mating parts. Tolerances on sheared and nibbled parts are usually plus or minus 1/32 of an inch. Minus tolerances with sectional dimensions of wood structural members such as spars should not exceed 1/32 inch in the fully seasoned condition unless justified by structural analysis. Plus tolerances are limited by assembly considerations.

C. *Technique.* *Technique and practices governing repair and alteration.* Technique and practices should be in accordance with repair practice outlined in this section and should not embody features which experience has shown to be unreliable or otherwise unsatisfactory.

18.60 STRUCTURES EMBODYING WOOD, FITTINGS, WIRES, CABLES, AND FABRIC.

18.600 GLUES AND GLUING.

18.6000 GRADES AND TYPES OF GLUE.

High-grade casein and approved synthetic resin glues¹² are satisfactory for making glue joints in aircraft elements. Casein glue is almost invariably used and for the time being is preferable to all other glues for general aircraft repair work. The glue manufacturer's directions should always be followed in the mixing and preparation of the adhesives.

18.6001 CONDITION OF SURFACES TO BE GLUED.

Wood surfaces that are to be glued should be smooth and true. Machine marks, chopped or loosened grain, and other surface irregularities are objectionable. Joints of approximately equal strength may be made between two planed or smoothly sawed surfaces that are equally true. In view of the usual poor joint obtained by making scarfs for a spar splice with a saw and plane, a joiner cut should always be used.

Roughening of wood surfaces by tooth planing, scratching, or sanding with coarse sandpaper is often practiced in the belief that it affords better surfaces for gluing. However, tests of joints made by the Forest Products Laboratory show no benefit from roughening the surfaces. Therefore, such practices are unnecessary and frequently are a distinct disadvantage. The wood must also be clean and free from varnish, shellac, lacquer, enamel, dope, or paint.

18.6002 PROPER GLUING CONDITIONS:

A strong joint in the wood is characterized by complete contact of glue and wood surfaces over the entire joint area and a continuous film of good glue between the wood layers that is unbroken by air bubbles or by foreign particles. Making strong glued joints with glue applied in regular condition depends primarily upon a proper correlation between gluing pressure and glue consistency at the moment a pressure is applied. The consistency of the glue mixture after being spread on the wood is extremely variable, depending upon such factors as the kind of glue, moisture content of the wood, temperature of the glue room, and the extent to which the glue-coated surfaces are exposed to the air. Good joints may be made by coating either one or both contact faces of the parts to be joined. However, under adverse conditions of gluing, as when the glue becomes very thick before pressing, double spreading is known to be more reliable. For casein glue on Sitka spruce, the assembly time (before clamping) should be 1 to 20 minutes when the pieces are laid together immediately after applying the glue or 1 to 8 minutes if the glue-covered surfaces are left exposed to the air prior to clamping, the shorter periods being for a thick glue consistency and the longer ones for a medium consistency.

18.6003 GLUING PRESSURE.

The functions of pressure are to squeeze the glue out into a thin continuous film between the wood layers, to force air from the joint, to bring the wood surfaces into intimate contact with the glue, and to hold them in this position during the setting of the glue. A light pressure should be used with a thin glue, a heavy pressure with a thick glue, and corresponding variations in pressure should be made with glues of intermediate consistencies. This is accomplished by means of clamps, presses, or other mechanical devices. For softwoods, such as spruce, a pressure of 125 to 150 pounds per square inch should be used with a relatively thick glue represented by average casein glue. In gluing hardwoods a pressure of 150 to 200 pounds per square inch should be applied.

¹² For approved resinous glues see Civil Aeronautics Administration Product and Process Specification, P & P, 8-1, Glue, Synthetic Resin.

18.6004 **PRESSING TIME AND MEANS FOR APPLYING PRESSURE.**

The pressing time for casein and animal glue joints should, in general, be 7 hours or more. Glue joints increase in strength mainly as a result of drying. Hence, where it is convenient to do so, it is better to maintain pressure from one day to the next. It should be borne in mind that the longer pressing periods are desirable, as this enables the joints to reach a higher proportion of their final strength before being disturbed.

On small joints such as found in wood ribs, the pressure is usually applied only by nailing the joint gussets in place after spreading the glue. Since small nails must be used to avoid splitting, the gussets must be comparatively large in area to compensate for the relative lack of pressure. Nail spacing should be at least four per square inch and should in no event be less than one nail per lineal inch. Small brass screws may also be used advantageously where the particular parts to be glued are relatively small and do not allow application of pressure by means of clamps. Spar splices should always be clamped by means of cabinetmaker's parallel clamps or similar types. Handspring clamps should be used in conjunction with softwood only. Due to their limited pressure area, they must be applied with a pressure-distributing strip or block at least twice as thick as the member to be pressed. There should be at least two clamps per square inch of glue area.

18.601 **WING AND CONTROL SURFACES.**

18.6010 **GENERAL FLUTTER PRECAUTIONS.**

When repairing control surfaces, especially on high performance airplanes, care should be exercised that the repairs do not involve the addition of weight aft of the hinge line. Such procedure may adversely disturb the dynamic and static balance of the surface to a degree which would induce flutter. As a general rule it will be required to repair control surfaces in such a manner that the structure is identical to the original so that the weight distribution is not affected in any way.

18.6011 **SPLICING OF SPARS.**

The spars may be spliced at any point except under the wing fittings, which should not overlap any part of the splicing. Not more than two splices (excluding any splices the manufacturer may have incorporated in the original fabrication of the aircraft) will be considered satisfactory. Scarf joints should have minimum slopes of 10 to 1 for softwood and 15 to 1 for hardwood and plywood elements. Acceptable methods of splicing the various types of spars are shown in figures 1 through 6. An acceptable method of splicing box spar webs is shown in figure 8.

18.6012 **ELONGATED HOLES.**

In cases of elongated bolt holes in a spar or cracks in the vicinity of bolt holes, a new section of spar should be spliced in or the spar replaced entirely, unless the method of repair is specifically approved by an inspector of the Civil Aeronautics Administration. In many cases it has been found advantageous to laminate the new section of the spar (using aircraft plywood for the outer faces), particularly if the spar roots are being replaced.

18.6013 **LONGITUDINAL CRACKS AND LOCAL DAMAGE.**

Cracked spars (except box spars) may be repaired by gluing plates of spruce or plywood of sufficient thickness to develop the longitudinal shear strength of the spar to both sides of it. Such plates should extend well beyond the termination of the cracks. A total thickness of the spar web or total thickness of the plywood equal to one-fourth the spar web thickness should be used

as shown in figure 7. A method of repairing small local damage to either the top or bottom side of a spar is also shown in this figure.

18.6014 REPLACING SOLID TYPE SPARS WITH LAMINATED TYPE.

Solid spruce spars may be replaced with laminated ones¹³ or vice versa, provided the material is of the same high quality. External plywood reinforcements should always be replaced with plywood as in the original structure.

18.6015 WING AND CONTROL SURFACE RIBS.

Complete ribs should preferably be made from a manufacturer's approved drawing or from a drawing made by the repair agency and certified by the manufacturer as correct, except that the original rib may be used as a pattern in making the new rib if it is not too seriously damaged to permit comparison. Wood ribs should preferably not be attached to wood spars by nails driven through the rib cap strips, as this weakens the rib materially. The attachment should be by means of glue, with cement-coated, barbed, or spiraled nails driven through the vertical rib members on each side of the spar. The drawing or pattern should be retained by the repair agency for use by the inspector of the Civil Aeronautics Administration in making his inspection.

18.6016 REPAIRS OF WOOD STRUCTURES AT A JOINT, BETWEEN JOINTS, AT TRAILING EDGES, OR AT SPARS.

Acceptable methods of repairing damaged ribs are shown in figures 9 and 10.

18.6017 COMPRESSION RIBS.

Acceptable methods of repairing damaged compression ribs are shown in figure 11. Figure 11 (A) illustrates the repair of a compression rib of the "I" section type, i. e., wide, shallow cap strips, a center plywood web, with a rectangular compression member on each side of the web. The rib is assumed to be cracked through cap strips, web member, and compression member. Cut the compression member as shown in figure 11 (D), remove, and replace the shortest section, adding the reinforcing blocks as also shown in figure 11 (D). Cut and replace the aft portion of the cap strips, reinforcing as shown in figure 9, except that the reinforcing blocks are split in the vertical direction to straddle the center web. The plywood side plates, as indicated in figure 11 (A), are glued on. These plates are added to reinforce the damaged web.

Figure 11 (B) illustrates a compression rib of the type that is basically a standard rib with rectangular compression members added to one side and a plywood web to the other side. The method used in this repair is essentially the same as in figure 11 (A) except that the plywood reinforcing plate shown solid black in section B-B of figure 11 is continued the full distance between spars.

Figure 11 (C) illustrates a compression rib of the "I" type with a rectangular vertical member each side of the web. The method of repair is essentially the same as in figure 11 (A) except that the plywood reinforcing plates on each side shown in solid black in section C-C are continued, as in figure 11 (C), the full distance between spars.

18.6018 TRAILING AND LEADING EDGES AND TIP STRIPS.

Repairs to wing and control surface trailing and leading edges and tip strips should be made by properly executed and reinforced splices. Acceptable methods of trailing edge repairs are shown in figure 12.

18.602 STRESSED SKIN PLYWOOD COVERING.

¹³ Special methods of fabricating laminated spars may be found in Aircraft Airworthiness Section Rept. No. 15, copy of which may be obtained from Chief, Correspondence Section, Civil Aeronautics Administration, Washington, D. C.

18.6020 GENERAL CONSIDERATIONS.

Extensive repairs to damaged stressed skin on monocoque types of plywood structures should best be made at the factory of origin or by a certificated repair station certificated for this type of work. In any event such work should only be undertaken by a *certificated mechanic* or supervised by him if thoroughly experienced in this type of work. The repairs should preferably be made in accordance with specific recommendations from the manufacturer.

18.6021 EXTENSIVE DAMAGE.

If the damage is very extensive, repairs should be made by replacing the entire panel from one structural member to the next. Where holes are large, the seam should be made to lie along a bulkhead or along a structural member. Small brass wood screws have been found to be best suited for accomplishing a satisfactory glue joint in plywood splices. However, cement-coated, barbed or spiraled nails are considered satisfactory.

18.6022 SMALL HOLES.

Small holes not exceeding 3 inches in diameter may be repaired by gluing a plywood patch over the hole.

18.603 FINISHING OF WOODEN STRUCTURES.

Repaired ribs, spars, and other internal members should be finished by applying at least two coats of varnish or lionoil. Built-up box spars and similar closed structures should be protected on the interior by at least one heavy coat of varnish or lionoil. Surfaces which are likely to come in contact with fabric during the doping process should be treated with a dopeproof paint, cellophane tape, etc., to protect them against the action of the solvents in the dope. Zinc chromate primer may also be used as a dopeproof coating.

18.604 FITTINGS.

18.6040 INSPECTION FOR DEFECTS.

Fittings should be free from scratches, scribe, vise and nibbler marks, and sharp corners. When repairing aircraft after an accident or in the course of a major overhaul, all highly stressed main fittings should best be magnafluxed, etched, and cadmium or zinc plated. A careful examination of the fitting with a medium power (at least 10 power) magnifying glass will be considered an acceptable inspection for the time being.

18.6041 TORN, KINKED OR CRACKED FITTINGS.

Torn, kinked, or cracked fittings should be replaced and not repaired.

18.6042 ELONGATED OR WORN BOLT HOLES.

Elongated holes in fittings which were designed without bushings should not be reamed oversize but such fittings should be replaced unless the method of repair is approved by a representative of the Civil Aeronautics Administration. Holes should not be filled with welding rod. Acceptable methods of repairing elongated or worn bolt holes in landing gear, stabilizer, interplane or cabane strut ends only, not originally equipped with pin plates, are shown in figure 13. (See also fig. 22 on longeron repair at a fitting.)

18.605 WIRE BRACING AND CONTROL CABLES.

18.6050 INJURED, DISTORTED OR WORN CABLES.

Wires and control cables should be replaced if injured, distorted, worn or corroded even though the strands are not broken.

18.6051 SUBSTITUTION OF CABLE.

Substitution of cables for hard or streamlined wires will not be acceptable unless specifically approved by a representative of the Civil Aeronautics Administration. Neither wires nor cables should be subjected to heat. Soldering bonding braid to control cable will not be considered satisfactory.

18.6052 CABLE TERMINAL SPLICING OR WRAPPING

Control cables $\frac{3}{32}$ inch and above of the 6 by 19 or 7 by 19 extra-flexible type, and 6 by 7 or 7 by 7 flexible type cable used in primary flight control should be spliced and not soldered, using standard Army and Navy tuck splices of at least five full tucks, or a Roebling roll of at least seven full turns. Standard wrapped and soldered splices will be acceptable for flexible type flight control cables of less than $\frac{3}{32}$ inch in diameter, and for the end terminals of cables made from aircraft strand (19 wires). For dimensions of splices see figure 14. "Administrator of Civil Aeronautics Approved" swaged cable terminals will be considered satisfactory substitutes for spliced cable ends.

18.6053 SAFETYING OF TURNBUCKLES.

All turnbuckles should be safetied with safety wire in the following manner:

Two separate lengths of wire should be used. One length of wire is to be run through the holes in the barrel of the turnbuckle and the ends of the wire bent toward opposite ends of the turnbuckle. The second length of wire is then to be passed through the hole in the barrel and the ends bent along the barrel on the opposite sides from the first length. The wires at one end of the turnbuckle are passed through the eye in opposite directions and one wire laid along the barrel, while the other wire is wrapped at least four turns around the shank of the turnbuckle and the wire alongside the barrel before cutting off the end. The remaining length of safety wire should then be wrapped at least four turns around the shank of the turnbuckle and cut-off. Repeat this same wrapping procedure with the wire ends at the opposite end of the turnbuckle.

18.606 FABRIC COVERING AND FINISHING.**18.6060 GRADE OF TEXTILE MATERIALS.**

All fabric surface tape, reinforcing tape, machine thread, lacing cord, etc., used for recovering or repairing an aircraft structure should be of high-grade aircraft textile material of at least as good quality and equivalent weight as that originally used on the aircraft. (See table 6 for textile materials acceptable for aircraft covering.)

18.6061 SEAMS.

All seams should be plain lap, folded fell or French fell seams, machine stitched. (See (E), (F), (G), fig. 16.) Eight to ten stitches per inch should be used. The row of stitches nearest each folded edge of each seam should be approximately $\frac{1}{16}$ inch from the edge of the fold and the rows should be $\frac{1}{4}$ to $\frac{3}{8}$ inch apart. (See (E), (F), (G), fig. 16.)

- (a) All seams should be parallel to the line of flight, except as outlined in (b). Seams should preferably not cover a rib or be so placed that the lacing will be through or over the seam. In the case of tapered wings or control surfaces the seams should be disposed so as to cross the fewest number of ribs consistent with efficient cutting of the pattern.
- (b) The only seam extending spanwise of the wing or control surface, whether hand or machine sewn, should be at the trailing edge, except that in

the case of tapered wings or control surfaces additional seams may be made at the tapered portion at the leading edge. This seam should be covered in all cases by a strip of surface tape.

18.6062 COVERING.

Fabric should be so applied to all wings that the warp threads (threads running parallel to the selvage edges) should be parallel to the line of flight. Either the envelope method or blanket method of covering will be acceptable. In the case of surfaces having metal ribs with relatively sharp edges (stamped types) commercial tape should be applied over these edges before covering to prevent abrasion of the rib lacing cord.

- (a) *The Envelope Method* of covering is accomplished by sewing together widths of fabric cut to specific dimensions and machine sewn to form an envelope which can be drawn over the frame. The trailing and the outer edges of the covering should be machine sewn unless the frame is not favorably shaped for such sewing, in which case the fabric should be joined by hand sewing as described herein for the blanket covering.
- (b) *The Blanket Method* of covering is accomplished by sewing together widths of fabric of sufficient lengths to form a blanket covering for all surfaces of the frame. The trailing and outer edges of the covering should be joined by using a plain over-throw or baseball stitch, except that on airplanes with design gliding speeds of 180 miles per hour or less the blanket may be lapped at least 1 inch and doped to the trailing and outer edges of wing and control surface structures and to fuselage structures. In fabricating both the envelope and blanket coverings, the fabric should be cut in lengths sufficient to pass completely around the frame, starting at the trailing edge and returning to the trailing edge.
- (c) *Hand Sewing or Tacking* should begin at a point where machine sewing stops and should continue to a point where machine sewing or uncut fabric is reached. Hand sewing should best be locked at intervals of 6 inches, and the seams should be properly finished with a lock stitch and a knot. (See (D) fig. 16.) At the point where hand sewing or permanent tacking is necessary, the fabric should be so cut that it can be doubled under before sewing or permanent tacking. (See fig. 16 (C).) Temporary tacks should be removed by a straight pull in such a manner that the fabric is not torn nor damaged. In hand sewing there should be a minimum of four stitches per inch.
- (d) *An Adequate Number of Drain Grommets* properly located to insure complete drainage and ventilation of the wing or control surface should be installed.

18.6063 REINFORCING TAPE.

Reinforcing tape of at least the width of the cap strips should be placed under all lacings. Tape under moderate tension should be tacked or otherwise attached at the trailing edge of ribs and brought around the leading edge, back to the trailing edge, where it should be tacked again or otherwise attached. Where a wide cap-strip or rib occurs, two widths of reinforcing tape may be used. In the case of wings with plywood or metal sheet from the nose to the front spar, the reinforcing tape need be brought only to the front spar on the upper and lower surfaces.

18.6064 WING LACING.

Both surfaces of fabric covering on wings and control surfaces should be securely fastened to the ribs by rib lacing cord or any other method originally approved for the aircraft. Care should be taken to insure that all sharp edges against which the lacing cord may bear are adequately protected by commercial tape in order to prevent abrasion of the cord. Typical methods of attaching fabric at aileron cut-outs and wing butts together with the technique of tying a modified Seine knot for securing the lacing may be found in figure 16.

- (a) The stitch spacing should not exceed the spacing approved on the original aircraft. In case the spacing cannot be ascertained due to destruction of the covering, acceptable rib stitch spacing may be found in figure 15 (A). All lacing cord should be lightly waxed with beeswax for protection. In the case waxed braided cord is used, this procedure is unnecessary. (See table 6 for acceptable lacing cords.)
- (b) A slip knot, for tightening, should be used at the first point of lacing. The cord should then be carried to the next point of lacing at which point and at all subsequent ones the lacing should be secured by Seine knots. The cord should be secured at the finish of the lacing by tacking or by a double or lock knot.

18.6065 FUSELAGE LACING.

Fabric lacing is also necessary in the case of deep fuselages, and on fuselages where former strips and ribs shape the fabric to a curvature. In the latter case the fabric should best be laced at intervals to the formers. The attachment of fabric to fuselages should be so accomplished as to be at least the equivalent in strength and reliability to that used by the manufacturer of the airplane.

18.6066 FINISHING TAPE.

All lacing should be covered with suitable tape of at least the same quality and width as was used on the original airplane. This tape should not be applied until the first coat of dope has dried. All inspection openings should be reincorporated into the covering, and the fabric around them and along leading edges suitably reinforced with tape. Where there is wear or friction induced by a moving part or fitting, a leather patch should be sewed to a fabric patch, and this finished patch doped in place.

18.6067 DOPING.

The total number of coats of dope should not be less than necessary to result in a taut and well-filled finish job. A guide for finishing fabric-covered aircraft is represented by the following:

- (a) Two coats of clear nitrate dope, brushed on or applied by an equally satisfactory method to assure penetration (high-pressure spray) and sanded after second coat.
- (b) One coat of clear nitrate dope, either brushed or sprayed, and sanded.
- (c) Two coats of aluminum pigmented dope, sanded after each coat.
- (d) Three coats of pigmented dope (the color desired), sanded and rubbed to give a smooth glossy finish when completed.
- (e) Precaution should be taken not to sand heavily over the center portion of pinked tape and over spars in order not to damage the rib stitching cords and fabric.

18.6068 PATCHING OF FABRIC.

- (a) Small tears should be repaired by sewing the torn edges together and dopping a piece of pinked edge fabric over the tear. In sewing up the tear the baseball stitch should be used with the stitches not more than $\frac{1}{4}$ inch apart and extending back into the cover, away from the edge of the tear about $\frac{1}{4}$ inch so they will not readily pull out. If the tear is a straight rip the sewing is started at one end so that as the seam is made the edges will be drawn tightly together throughout its entire length. If the opening is V-shaped, as is often the case when openings are cut in wings to inspect the internal structure, the sewing should start at the corner or point so that the edges of the cover will be held in place while the seams are being made. The sewing is done with a curved needle and well waxed thread as necessary for all hand sewing. The surface over which the patch is to be applied must be clean and free from paint or varnish. Any dirt, grease, varnish, or paint may be removed by rubbing the surface with a rag dipped in dope and wiping dry with a clean rag, or by scraping the surface with a putty knife after it has been softened with fresh dope. Dope solvent or acetone may be used for the same purpose but care should be taken that it does not drip through on the inside of the opposite surface causing the dope to blister. A patch of sufficient size is cut from airplane cloth to cover the tear and extend at least $1\frac{1}{2}$ inches beyond the tear in all directions. The edges of the patch should either be pinked similar to surface tape or frayed out about $\frac{1}{4}$ inch on all edges. (See fig. 15 (B).)
- (b) In some cases the damaged portion of the fabric may be too badly frayed for the above method to be used and at the same time is not large enough to warrant the method described below. In such cases a sewed-in patch should be used. The damaged portion of the covering is cut out making an opening regularly shaped, that is, either rectangular or triangular. A piece of new fabric is cut to $\frac{1}{2}$ inch beyond the opening on all sides. The edges of this fabric are turned under $\frac{1}{2}$ inch and sewed to the edges of the opening. The patch should be held in place by a few temporary stitches at the corners while the seams are made. The seams are made in the same manner as for repairing small tears. When the sewing is completed, the patch is doped in the usual manner, surface tape being applied over the seams with the second coat.
- (c) When the injury is so large that neither of the above methods can be used, the procedure should be as follows: New fabric is sewed to the old cover at a point beyond the adjacent ribs, and should extend from the leading edge to the trailing edge. The new cover is laced to the ribs over the lacing and stitching of the original cover which is not removed. The usual reinforcing tape and lacing cord should be used to attach the patch to the airfoil. Surface tape should be placed at the leading edge and at the trailing edge to give a finished appearance to the patch. Due to the light construction of wooden rib caps, it is advisable to *avoid the use of tacks.*

18.6069 METAL FASTENERS FOR FABRIC.

When self-tapping screws are used for the attachment of fabric to the rib structure, the following procedure should be observed:

- (a) The holes should be redrilled where found necessary due to wear, distortion, etc., and in such cases a screw one size larger should be used as a replacement.

- (b) The length of the screw should be sufficient so that at least two threads of the grip (threaded part) extend beyond the rib cap strip.
- (c) A thin washer, preferably celluloid, should be used under the heads of screws and pinked-edge tape should be doped over each screw head.

18.61 WELDED STEEL STRUCTURES.

18.610 GENERAL.

The oxyacetylene process is still considered the most flexible type, generally best suited for repair work on aircraft structural elements. Unless the repair agency holds an approval for other methods of welding (electric arc or spot welding) in accordance with CAR 04.4012 as interpreted in CAM 04.4012, or a particular application of a different welding process is specifically approved by the Civil Aeronautics Administration, oxyacetylene torch welding only will generally be considered acceptable.

18.6100 PREPARATION FOR WELDING.

The elements to be welded should be properly held in place by welding jigs or fixtures which are sufficiently rigid to prevent misalignment due to expansion and contraction of the heated material and which positively and accurately locate the relative positions of the pieces to be welded together.

18.6101 TORCH SIZE.

The torch tips should be of proper size for the thickness of the material to be worked on. The commonly used sizes which experience has proven to be satisfactory are:

Thickness of steel in inches	Diameter of hole in tip	Drill size
0.015 to 0.031	0.026	71
0.031 to 0.065	.031	68
0.065 to 0.125	.037	63
0.125 to 0.188	.042	58
0.188 to 0.250	.055	54
0.250 to 0.375	.067	51

18.6102 WELDING RODS.

Welding rods of alloy steel are used in some cases to obtain a high unit strength in the deposited metal, especially for parts heat-treated after welding. A satisfactory welding wire for welding of chrome-molybdenum steel is found in a rod complying with Federal Specification QQ-W-351, Grade E, and Navy Department Specification 46R4b. Any commercially pure iron wire or low carbon steel rod will be considered satisfactory for general aircraft repair work, provided the parts do not require heat-treatment after welding.

18.6103 CONDITION OF COMPLETED WELD.

The finished weld should incorporate the following characteristics:

- (a) The seam should be smooth and of uniform thickness.
- (b) The weld should be built up to provide extra thickness at the seam.
- (c) The weld metal should taper off smoothly into the base metal.
- (d) No oxide should be formed on the base metal at a distance of more than $\frac{1}{2}$ inch from the weld.
- (e) The weld should show no signs of blow holes, porosity or projecting globules.
- (f) The base metal should show no signs of pitting, burning, cracking, or distortion.

18.6104 PRACTICES TO GUARD AGAINST.

No welds should be filed in an effort to make a smooth appearing job, as such treatment causes a loss in strength. Welds should not be filled with solder, brazing metal, or any other filler. When it is necessary to reweld a joint which was previously welded, all old-weld material should be thoroughly removed before rewelding. Never weld over weld if it can be avoided because continual heating causes the material to lose its strength and to become brittle.

18.6105 CLEANING PRIOR TO WELDING.

The parts to be welded should always be cleaned prior to welding by sandpapering or brushing with a wire brush or other similar methods. In case the members were metallized the surface metal should best be removed by careful sandblasting.

18.6106 HEAT-TREATED MEMBERS.

Members which depend on heat-treatment for their original physical properties should be reheat-treated after the welding operation. If the heat-treat value cannot be ascertained from the manufacturer of the aircraft involved, an acceptable heat-treat value may be determined by making Brinell or Rockwell hardness tests in several places of the member for the corresponding physical properties. (See table 5 for Rockwell tensile strength relations.)

18.6107 ROSETTE WELDS.

Rosette welds are generally employed to fuse an inner reinforcing tube (liner) with the outer member. Where a rosette weld is used, the hole should be made in the outside tube only and be of a sufficient size to insure fusion of the inner tube. A hole diameter of *approximately* one-fourth the tube diameter of the outer tube has been found to serve adequately for this purpose. In cases of tightly fitting sleeves or inner liners, the rosettes may be omitted.

18.611 TUBULAR MEMBERS DENTED, BENT, CRACKED, OR OTHERWISE DAMAGED.**18.6110 MEMBERS DENTED AT A STATION.**

If tubular members such as fuselage longerons have sustained local damage at a station, they may be repaired by the addition of a patch plate (finger plate) as shown in figure 17.

18.6111 MEMBERS DENTED, BENT, CRACKED, OR OTHERWISE DAMAGED.

Dented, bent, cracked, or otherwise damaged fuselage members may be repaired after first carefully straightening the member and then using a split sleeve reinforcement as shown in figure 18. The filling of kinks with welding rod in place of reinforcing the member by either of the methods shown in the above figures is not considered acceptable.

18.6112 REPAIRS AT A STATION OR BETWEEN STATIONS.

Fuselage members may be repaired at a station or between stations by various forms of acceptable splices as shown in figure 19.

Figure 19 (D) shows a method of repairing a longeron where the bays are short and there is difficulty in springing the longeron to install a sleeve. It is accomplished by *sawing out a section of the longeron and web members at the joint*, adding a new section of longeron and a sleeve made up of two pieces as indicated. The two pieces of sleeve are first slipped on the longeron, one piece on each longeron stub, and pulled back far enough to allow insertion of a tube the same size as the longeron and the length of the gap between the two ends of the longeron. The two pieces of sleeve are then brought together and welded at the center of the joint as indicated.

18.6113 SPECIAL LONGERNON SPLICES.

A typical longeron splice using the same diameter replacement tube and which is considered the most efficient type of repair in this category is shown in figure 20. An equally satisfactory longeron repair using a larger diameter replacement tube in connection with a fish-mouthed, telescoped joint may be found in figure 21.

18.612 BUILT-IN FUSELAGE FITTINGS.

Repairs of built-in fuselage fittings may be accomplished in a manner as shown in figure 22. The following outlines the different methods shown in the above figure:

18.6120 TUBE OF LARGER DIAMETER THAN ORIGINAL (fig. 22 (A)).

A tube (sleeve) of larger diameter than original is used in this method. This necessitates reaming the fitting holes (at longeron) to a larger diameter. The sleeve should extend approximately 6 inches forward (left of fitting) of the joint and 8 inches aft (right of fitting). The forward splice should be a 30° scarf splice. The rear longeron (right) should be cut off approximately 4 inches from the centerline of the joint and a spacer 1 inch long fitted over the longeron. This spacer and longeron should be edge welded. A tapered vee cut approximately 2 inches long should then be made in the aft end of the outer sleeve. The end of the outer sleeve should be swaged to fit the longeron and welded.

18.6121 TUBE OF SAME DIAMETER AS ORIGINAL (fig. 22 (B)).

In this method the new section of tube is the same size as the longeron forward (left) of the fitting. The rear end (right) of the tube is cut at 30° and forms the outside sleeve of a scarf splice. A sleeve is centered over the forward joint as indicated.

18.6122 SIMPLE SLEEVE (fig. 22 (C)).

The longeron is assumed the same size on each side of the fitting in this case and is repaired by a simple sleeve of larger diameter than the longeron.

18.6123 LARGE DIFFERENCE IN LONGERNON DIAMETER EACH SIDE OF FITTING.

Figure 22 (D) assumes that there is a quarter of an inch difference in the diameter of the longeron on the two sides of the fitting. The section of longeron forward (left) of the fitting is cut at 30° and a section of tubing of the same size as this tube and of such length as to extend well to the rear (right) of the fitting is slipped through it. One end is cut at 30° to fit the 30° scarf at left and the other end fish-mouthed as shown. This makes it possible to insert a tube of such diameter as to form an inside sleeve for the tube on the left of the fitting and an outside sleeve for the tube on the right of the fitting.

18.613 ENGINE MOUNTS.**18.6130 GENERAL CONSIDERATIONS.**

All welding on an engine mount should be of the highest quality since the vibration present tends to accentuate any minor defect present. Engine mount members should preferably be repaired by using a larger diameter replacement tube telescoped over the stub of the original member, and using fish-mouth and rosette welds as shown in figure 21. However, 30° scarf welds in place of the fish-mouth welds will be considered acceptable for engine mount repair work.

18.6131 CHECK OF ALINEMENT.

Repairs to engine mounts should be governed by accurate means of checking alinement. When new tubes are used to replace bent or damaged ones, the original alinement of the structure must be maintained. This can be done by measuring the distance between points of corresponding members that have not been distorted, and by reference to the manufacturer's drawings.

18.6132 CAUSE FOR REJECTION.

If all members are out of alinement, the engine mount should be replaced by one supplied by the manufacturer and the method of checking the alinement of the fuselage or nacelle points should be requested from the manufacturer.

18.6133 ENGINE MOUNT RING DAMAGE.

Minor damage such as a crack adjacent to an engine attachment lug may be repaired by rewelding the ring and extending a gusset or a mounting lug past the damaged area. Engine mount rings which have been extensively damaged should not be repaired but should be replaced unless the method of repair is specifically approved by an authorized representative of the Civil Aeronautics Administration.

18.614 LANDING GEARS.**18.6140 ROUND TUBE CONSTRUCTION.**

Landing gears made of round tubing may be repaired using standard splices as shown in figures 19 through 21.

18.6141 STREAMLINE TUBE CONSTRUCTION.

Landing gears made of streamlined tubing may be repaired by any one of the methods shown in figures 23 through 26.

18.6142 REPAIRABLE AND NONREPAIRABLE TYPES OF AXLE ASSEMBLIES.

Representative types of repairable and nonrepairable landing gear axle assemblies are shown in figure 27. The types as shown in A, B, and C of this figure are formed from steel tubing and may be repaired by any standard method shown in the preceding figures of this manual. However, it will always be necessary to ascertain whether or not the members are heat-treated.

The axle assembly as shown in figure 27 (D) is, in general, of a nonrepairable type for the following reasons:

- (a) The axle stub is usually made from a highly heat-treated nickel alloy steel and carefully machined to close tolerances. These stubs are usually replaceable and should be replaced if damaged.
- (b) The oleo portion of the structure is generally heat-treated after welding and is perfectly machined to assure proper functioning of the shock absorber. These parts would be distorted by welding after machining.

18.6143 SKIS.

Fractured wooden ski runners will usually require replacement but a split at the rear end of the runner whose length does not exceed 10 percent of the ski length may be repaired by attaching (glue and bolts) one or more wooden cross pieces across the top of the runner.

18.6144 SKI PEDESTALS.

- (a) *Tubular pedestals.* Damaged pedestals made of steel tubing may be repaired by using standard tube splices as shown in figures 19-26.
- (b) *Cast pedestals.* Cast pedestals should not be repaired but should be replaced unless the method of repair is specifically approved by a representative of the Civil Aeronautics Administration.

(c) *Sheet metal pedestals.* Damaged pedestals made of aluminum alloy sheet should be repaired in the general manner as outlined in section 18.64.

18.6145 FLOATS.

Damaged floats should be repaired in the general manner as outlined in Section 18.64 Aluminum and Aluminum Alloy Structures.

18.6146 WHEELS.

Seriously damaged wheels should not be repaired but should be replaced unless the method of repair is specifically approved by a representative of the Civil Aeronautics Administration.

18.615 BUILT-UP TUBULAR WING OR TAIL SURFACE SPARS.

Built-up tubular wing or tail surface spars may be repaired by using any of the standard splices and methods of repair shown in the figures of this manual provided the spars are not heat-treated. In the latter case the entire spar assembly would have to be reheat-treated to the manufacturer's specifications after completion of the repair. In general, this will be found less practicable than replacing the spar with one furnished by the manufacturer of the aircraft.

18.616 WING AND TAIL SURFACE BRACE STRUTS.

18.6160 GENERAL CONSIDERATIONS.

In general it will be found advantageous to replace damaged wing brace struts made either from round or streamlined tubing by new members purchased from the original manufacturer. However, there is no objection from an airworthiness point of view to repairing such members in a proper manner. An acceptable method in case streamlined tubing is used will be found in figure 24. Similar members made of round tubes may be repaired using a standard splice as shown in figure 19 (A).

18.6161 LOCATION OF SPLICES.

Brace struts must be spliced only adjacent to the end fittings.

18.6162 FIT AND ALINEMENT.

When making repairs to wing and tail surface brace members, particular attention should be paid to proper fit and alinement to avoid eccentricities.

18.617 REPAIRS TO JOINTS OF ARC WELDED PARTS.

Repairs to arc welded assemblies may be made by either of the following methods:

18.6170 REPLACING ARC WELDED JOINT.

Cutting out the arc welded joint and replacing it with one made by oxyacetylene welding, properly gusseted.

18.6171 REPLACING ARC WELD DEPOSIT.

Chipping out the metal deposited by the arc weld process and rewelding by oxyacetylene method after properly reinforcing the joint by means of inserts or external gussets.

18.618 STEEL PARTS NOT TO BE WELDED.

18.6180 BRACE WIRES AND CABLES.

Airplane parts that depend for their proper functioning on strength properties developed by cold working must not be welded. In this classification are streamlined wires and cables.

18.6181 BRAZED AND SOLDERED PARTS.

Brazed or soldered parts must not be welded, as the brazing mixture or solder will penetrate the hot steel and weaken it.

18.6182 NICKEL ALLOY STANDARD PARTS.

Steel parts, mostly of nickel alloy steels, which have been heat-treated to improve their physical properties must not be welded. This pertains particularly to aircraft bolts, turnbuckle ends, axles and other heat-treated alloy steel parts.

18.619 INSPECTION AFTER WELDING AND CORROSION PROTECTION.**18.6190 INSPECTION BY MAGNIFYING GLASS.**

The practice of filling hollow steel structures with hot linseed or petroleum base oils, under pressure, in order to coat the inside surface and inhibit corrosion, assists in the detection of weld cracks as the hot oil will seep through cracks invisible to the eye. This practice, though not in all cases applicable, is recommended where a large portion of the structure has been rewelded. Carefully examining all joints with a medium power magnifying glass (at least 10 power) after first removing all scale is considered an acceptable method of inspection for repaired structures.

18.6191 INSPECTION BY MAGNETIC POWDER.

Magnetic inspection by means of magnetic powder such as magnaflox and black rouge has proven to be a very efficient, practical nondestructive method. This process will indicate the presence of minute cracks or small blow holes. The surface to be examined should be reasonably smooth and free from scale as it is difficult to detect cracks in the irregular surface of the weld metal deposited. Sand blasting yields most satisfactory results but should only be used by experienced personnel.

18.6192 X-RAY INSPECTION.

X-ray inspection has had only limited application in the past on account of the inaccessibility of many joints and the necessity of taking exposures from several angles to insure detection of defect. However, the results are very satisfactory.

18.6193 EXTERIOR FINISH.

All steel parts and welded joints in the various units of an aircraft are covered with either paint, scale, or rust which must be removed before finishing. The most efficient method is careful sand blasting. Otherwise, the paint, scale, rust and dirt should be removed with fine emery cloth prior to applying a standard metal cleaner. When once cleaned, the metal should be finished immediately and not touched by ungloved hands until at least a priming coat has been applied; otherwise, corrosion will later set in. A very satisfactory protection for finishing the exterior of tubing is obtained by spraying or brushing two coats of zinc chromate primer with four ounces of aluminum bronze powder per unthinned gallon in the second coat of primer. This finish provides excellent protection against corrosion and is very dopeproof. Any equivalent finish using oil base primers and enamels is acceptable. The portions of the structure coming in contact with doped fabric should be given a protecting strip of tape or a coat of dopeproof paint if the base finish is not already dopeproof. Adhesive tape is also very satisfactory for this purpose.

18.6194 INTERIOR FINISH.

Corrosion proofing of the interior steel tubular structures can be most satisfactorily accomplished by filling the structures with hot linseed oil or petroleum base oil under pressure and draining the oil prior to sealing. Sealing the members only without the use of oil by permanently closing all openings to prevent air from circulating through them will also be considered an acceptable method for protecting the interior of repaired structures.

18.62 STAINLESS STEEL STRUCTURES.**18.620 GENERAL CONSIDERATIONS.**

Structural components made from stainless steel, particularly the "18-8" variety (18 percent chrome, 8 percent nickel), joined by the very rapid process of spot welding, should only be repaired at the factory of origin or by a repair station designated by the manufacturer and rated by the Civil Aeronautics Administration to perform this type of work, unless the repair method incorporates bolted or riveted connections which are specifically approved by an authorized representative of the Civil Aeronautics Administration.

18.621 SECONDARY STRUCTURAL AND NONSTRUCTURAL ELEMENTS.

Elements such as tip bows or leading and trailing edge tip strips of wing and control surfaces may be repaired by soldering with a 50-50 lead-tin solder or a 60-40 alloy of these metals. For best results a flux of phosphoric acid (syrup) should be used. Since the purpose of a flux is to attack the metal so that the soldering will be effective, any excess flux should be removed by washing the joint. Due to the high heat conductivity of stainless steel, a soldering iron large enough to do the work properly must be used. Leaky spot welded seams in a boat hulls, fuel tanks, etc., should be repaired in a similar manner.

18.63 RIVETED OR BOLTED STEEL TRUSS TYPE STRUCTURES.**18.630 GENERAL CONSIDERATIONS.**

Repairs to riveted or bolted steel truss type structures should be made employing the general principles outlined in the following sections on aluminum alloy structures. Methods of repair of vital members should specifically be approved by a representative of the Civil Aeronautics Administration.

18.64 ALUMINUM AND ALUMINUM ALLOY STRUCTURES.**18.640 GENERAL CONSIDERATIONS AND PROOF OF STRENGTH.**

Extensive repairs to damaged stressed skin on monocoque types of aluminum alloy structures should best be made at the factory of origin or by a repair station rated for this type of work. In any event such work should only be undertaken by a certificated mechanic if thoroughly experienced in this type of work. The repairs should preferably be made in accordance with specific recommendations of the manufacturer of the aircraft. In many cases repair parts, joints, or reinforcements can be designed and proof of adequate strength shown without the calculation of the actual loads and stresses by properly considering the material and dimensions of the original parts and the riveted attachments. Examples illustrating the principles of this method as applied to typical repairs are given in the appendix of this manual or may be found in textbooks on metal structures. An important point to bear in mind in making repairs on monocoque structures is that a repaired part must be as strong as the original with respect to *all* types of loads and general rigidity.

18.6400 UNCONVENTIONAL ATTACHMENTS.

"Rivnuts," "Lock-scrus," drive screws or self-tapping screws, and other unconventional or new attachment devices should not be used in primary structure unless approved by the Civil Aeronautics Administration.

18.6401 ALUMINUM ALLOY BOLTS.

Aluminum alloy bolts less than ½-inch diameter should not be used in primary structure and aluminum alloy bolts and nuts will not be permitted where they will be repeatedly removed for purposes of maintenance and inspection.

18.6402 ALUMINUM ALLOY NUTS.

Aluminum alloy nuts may be used on steel bolts in shear in land planes provided the bolts are cadmium plated, but must not be used on seaplanes.

18.6403 SELF-LOCKING NUTS.

Self-locking nuts may be used in the primary structure subject to the restrictions outlined in the Civil Aeronautics Administration Product and Process Specification ¹⁴ on Self-Locking Nuts.

18.6404 DRILLING OVERSIZE HOLES.

Great care should be exercised to avoid drilling oversize holes or otherwise decreasing the effective tensile area of wing spar cap strips, wing, fuselage, or fin longitudinal stringers, or other highly stressed tensile members. All repairs or reinforcements to such members should be done in accordance with factory recommendations and with the approval of a representative of the Civil Aeronautics Administration.

18.6405 DISASSEMBLY PRIOR TO REPAIRING.

If the parts to be removed are essential to the rigidity of the complete structure, the remaining structure should be adequately supported prior to disassembly, in such a manner as to prevent distortion and permanent damage to the remainder of the structure. Rivets may be removed by using special tools developed for the purpose or by center-punching the heads, drilling not quite through with a drill of the same size as the rivets and shearing the heads off by a sharp blow from a small cold chisel. Riveted joints adjacent to the damaged parts should be inspected for partial failure (slippage) by removing one or more rivets to see if the holes are elongated or the rivets have started to shear.

18.6406 IDENTIFYING MATERIAL.

When replacement parts are to be made up, the material specifications of the original parts should be determined with regard to type of alloy, temper (or heat-treatment), and gage thickness. Material specifications are given by numbers and letters and will usually be found on the interior surfaces of sheets, or given in the manufacturer's service manual. The types of alloy in common use for structural parts of sheet metal and extruded structural shapes are designated as 24ST and 17ST, the former having the higher strength properties. The numbers designate the chemical composition. The "S" indicates that the material is wrought (not cast), and the "T" indicates that it is in the hard tempered condition (it is heat-treated, aged, and possibly cold worked). Sheet material designated as 24SRT, where the "R" indicates that the material has been given additional cold working to obtain a yield strength higher than that of 24ST, has certain characteristics which have resulted in its being used only for special applications, for instance, some beam webs and corrugated compression members in wings.

18.6407 SIMPLE TEST FOR IDENTIFYING HEAT-TREATED ALLOYS.

If for any reason the identification of the alloy is not on the material, it is possible to distinguish between heat-treatable alloys containing copper and non-heat-treatable alloys by immersing a sample of the material in a 10-percent solution of caustic soda (sodium hydroxide). The heat-treated alloys will turn black due to the copper content, whereas the others will remain bright. In the case of Alclad, the surface will remain bright but there will be a dark area in the middle when viewed from the edge.

¹⁴ May be obtained from Chief, Publications and Statistics Division, Washington, D. C.

18.641 SELECTION OF MATERIAL FOR REPLACEMENT PARTS.

In selecting the alloy, it is usually satisfactory to use 24ST in place of 17ST since the former is stronger. Hence, it will not be permissible to replace 24ST by 17ST unless the deficiency in strength of the latter material has been compensated for by an increase in material thickness or the structural strength has been substantiated by tests or analyses. The choice of temper depends, of course, upon the severity of the subsequent forming operations. Parts having single curvature and straight bend lines with a large bend radius may advantageously be formed from "ST" material, while a part such as a fuselage frame would have to be formed from "S-C" (soft annealed sheet) and heat-treated to the "ST" condition after forming. Sheet metal parts which are to be left unpainted should be made of "Alclad" (Aluminum coated) material. All sheet material and finished parts should be free from cracks, scratches, kinks, tool marks, corrosion pits, and other defects conducive to cracking.

18.6410 FORMING SHEET METAL PARTS.

Bend lines should preferably be made to lie at an angle to the grain of the metal (preferably 90°). Before bending, all rough edges should be smoothed, burrs removed, and relief holes drilled at the ends of bend lines and at corners to prevent cracks from starting. For material in the "ST" condition, the bend radius should be large. See table 4 for recommended bend radii.

18.642 HEAT TREATMENT.

All structural aluminum alloy parts should be heat-treated in accordance with the heat treatment instructions issued by the manufacturers of the materials. If the heat treatment produces warping, the parts should be straightened immediately after quenching. Parts riveted together should be heat-treated before riveting, since heat-treating after riveting causes warping. Also, when riveted assemblies are heated in a salt bath, the salt cannot be entirely washed out of the crevices and causes corrosion.

18.643 RIVETS AND RIVETING PRACTICE.**18.6430 IDENTIFICATION OF RIVET MATERIAL.**

The kinds of rivets in general use, listed in the order of their decreasing strength properties are:

- (a) 24ST, identified by two small raised radial dashes at the ends of a diameter on the periphery of the head.
- (b) 17ST, identified by a small raised spot or pimple in the center of the head.
- (c) A17ST, identified by a small depression or dimple at center of head.
(See fig. I, appendix I.)

Rivets may be replaced by a kind of higher strength properties, but not vice versa, unless the lower strength is compensated for by an increase in diameter or a greater number of rivets. It is advisable to stock all rivets in the heat-treated condition (ST), in order to prevent unheat-treated rivets being used. The A17ST rivets may be driven in the condition received, but the 17ST rivets above $\frac{1}{16}$ inch in diameter and all 24ST rivets should be reheat-treated just prior to driving as they would otherwise be too hard for satisfactory riveting.

18.6431 RIVET SIZE.

In replacing rivets, the original size should be used if this size will fit and fill the holes. If not, the holes should be drilled or reamed for the next larger size rivet. A general rule for selecting rivets of the proper diameter to join aluminum alloy is approximately three times the thickness of the heavier

sheet, or somewhat larger for thin sheets. Dimensions for forming flat rivet heads are shown in figure I of appendix I, together with commonly found rivet imperfections, which should be guarded against.

18.6432 RIVET SPACING.

The rivet pattern should be designed for the strength required but in general good practice the spacing should not be closer than shown in figure II of appendix I. Rivets should never be used where they would be placed in direct tension, tending to pull the heads off.

18.6433 USE OF A17ST ALUMINUM ALLOY REPLACEMENT RIVETS.

It will be considered acceptable to replace all 17ST rivets of $\frac{3}{16}$ -inch diameter or less, and also all 24ST rivets of $\frac{5}{32}$ -inch diameter or less, with rivets for general repairs, provided the replacement rivets are $\frac{1}{32}$ inch greater in diameter than the rivets they replace.

18.6434 HOLLOW RIVETS.

Hollow rivets should not be substituted for solid rivets in load carrying members without specific approval of the application by a representative of the Civil Aeronautics Administration.

18.6435 PRECAUTIONS WHEN RIVETING.

When adding or replacing rivets adjacent or near to 17ST or 24ST rivets which have been installed previously, great care should be exercised or the older rivets will be loosened or may fail due to sharp vibrations in the structures caused by the action of the rivet gun and bucking bar. In every case all adjacent rivets should be carefully examined after the repair or alteration is finished to ascertain that they have not been harmed by adjacent operations.

18.644 REPAIR METHODS.**18.6440 SPLICING OF TUBES.**

Round or streamlined tubular members may be repaired by splicing as shown in figure 28. Splices in struts should be adjacent to the fittings.

When solid rivets go completely through hollow tubes, their diameter should be at least one-eighth of the outside diameter of the outer tube. Rivets which are loaded in shear should be hammered only enough to form a small head, and no attempt should be made to form the standard round head. The amount of hammering required to form the standard round head often causes the rivet to buckle inside the tube. Satisfactory rivet heads may be produced in such installations by spinning, if the proper equipment is available. Correct and incorrect examples of this type of rivet application are incorporated in figure 28.

18.6441 REPAIRS TO 24SRT ALLOY MEMBERS.

Repairs involving 24SRT alloy members should be made with the same material.

18.6442 WING AND TAIL SURFACE RIBS.

Damaged aluminum alloy ribs either of the stamped sheet metal type or the built-up type employing special sections, square or round tubing, may be repaired by the additions of suitable reinforcements. Acceptable methods of repair are shown in figures 29 and 30. These examples deal with types of ribs commonly found in small and medium size aircraft. Any other method of reinforcement should be specifically approved by a representative of the Civil Aeronautics Administration.

18.6443 PATCHING OF SMALL HOLES.

Small holes in skin panels which do not involve damage to the stiffening members may be patched by covering the hole with a patch plate in the manner shown in figure 31.

18.6444 REPLACEMENT OF PORTIONS OF SKIN PANELS.

In case metal skin is damaged extensively, repairs should be made by replacing an entire sheet panel from one structural member to the next. The repair seams should be made to lie along stiffening members, bulkheads, etc., and each seam should be made exactly the same in regard to rivet size, spacing and rivet pattern as the parallel manufactured seams at the edges of the original sheet. If the two manufactured seams are different, the stronger one should be copied. See figure 31 for typical acceptable methods of repairs.

18.6445 SPLICING OF SHEETS.

In some cases the method of copying the seams at the edges of a sheet may not be satisfactory, for example, when the sheet has cut-outs, or doubler plates at an edge seam, or when other members transmit loads into the sheet. In these cases the splice should be designed to carry the full allowable tension load for the sheet. (An example to illustrate such a case is given in appendix I.)

18.6446 STRAIGHTENING OF STRINGERS OR INTERMEDIATE FRAMES.

(a) *Members slightly bent.* Members which are slightly bent may be straightened cold and examined with a magnifying glass for injury to the material. The straightened parts should then be reinforced to an extent depending upon the condition of the material and the magnitude of any remaining kinks or buckles. If any strain cracks are apparent, complete reinforcements should be added by following the manufacturer's "Administrator of Civil Aeronautics Approved" recommendations and the attachment of the reinforcements should be made in sound metal beyond the damaged portion.

(b) *Local heating.* Local heating should never be applied to facilitate bending, swaging, flattening, or expanding operations on heat-treated aluminum alloy members. It is unnecessary for the usual run of work in general practice, and it is impossible to control the temperature closely enough to prevent possible damage to the metal or impairing its corrosion resistance. However, a torch with a large, soft flame is sometimes played over the surface of the cold worked aluminum of the nonheat-treatable alloys to anneal for bending or forming. This practice is permissible for these types of alloys when it is impracticable to anneal in a furnace or bath. The metal should not be heated above a temperature indicated by charring a resinous pine stick.

18.6447 SPLICING OF STRINGERS AND FLANGES.

Splices should best be made in accordance with the manufacturer's recommendations usually contained in an "Administrator of Civil Aeronautics Approved" repair manual. Stringers should be designed to carry both tension and compression. For general design considerations and determination of strength see Appendix I or textbooks on aircraft structures. See figure 34 for general design.

(a) *Size of splicing members.* When the same material is used for the splicing member as was used in the original member, the net cross-sectional area (i. e., the shaded areas in fig. III, appendix I) of the splicing member should in general be greater than the area of the section element which it splices.

(b) *Number of rivets in splice.* The number of rivets required on each side of a cut in a stringer or flange may be determined from standard textbooks on aircraft structures. In any case the rivets should be arranged in the splice so that the design tensile load for the member and

splice plate can be carried into the splice without failing the member at the outermost rivet holes. (See appendix I.)

18.6448 REPAIRING CRACKED MEMBERS.

Acceptable methods of repairing various typical types of cracks occurring in service in structural elements from various causes are shown in figures 32, 34, 35, and 36. The following general procedure should be followed in repairing such defects:

- (a) Small holes $\frac{3}{32}$ -inch (or $\frac{1}{8}$ -inch) should be drilled at the extreme ends of the cracks to prevent their spreading further.
- (b) Reinforcements as shown in these figures should be added to carry the stresses across the damaged portion and stiffen the joints.

The condition causing such cracks to develop at a particular point is stress concentration at that point in conjunction with repetition of stress (such as produced by vibration of the structure). The stress concentration may be due to the design or to defects such as nicks, scratches, tool marks, and initial stresses or cracks from forming or heating treating operations. It should be noted that an increase in sheet thickness alone is usually beneficial but does not necessarily remedy the conditions leading to cracking.

18.6449 FITTINGS.

Damaged fittings should be replaced with new parts having the same material specifications or the method of repair should be specifically approved by a representative of the Civil Aeronautics Administration.

18.645 FUEL TANKS AND FUEL SYSTEMS.

18.6450 WELDED OR RIVETED TYPE TANKS.

If tanks are made of commercially pure aluminum, 3S, 52S, or similar alloys, they may be repaired by welding. Tanks made from heat-treatable aluminum alloys are generally assembled by riveting. In case it is necessary to rivet a new piece in place, a sealing compound that is insoluble in gasoline should be employed in the seams. Bakelite varnish, "Glyptalac," marketed by General Electric Co.; "Thiokol" made by the Thiokol Corporation, Yardville, N. J., or "Neoprene," made by the E. I. DuPont de Nemours & Co.; zinc chromate compound (type No. 2) made by the W. P. Fuller Co. of Los Angeles, Calif., are examples of sealing compounds which are acceptable.

- (a) *Removal of flux after welding.* It is especially important, after repair by welding, to completely remove all welding flux in order to avoid possible corrosion. Therefore, promptly upon completion of welding, the tank should be washed both inside and outside with liberal quantities of hot water, and drained. Next, either immerse it in 5 percent nitric or sulphuric acid or fill the tank with this solution (in which case also wash the outside with the same solution). Permit this acid to remain in contact with the weld about one hour and then rinse thoroughly with clean, fresh water. The efficiency of the cleaning operation may be tested by applying some acidified 5 percent silver nitrate solution to a small quantity of the rinse water that has been used to last wash the weld. If a heavy white precipitate is formed, the cleansing has been insufficient and the washing should be repeated.

18.6451 FUEL LINES.

Aluminum or aluminum alloy tubing should not be annealed after forming or at overhaul periods as is required practice with copper tubing.

18.646 SPOT OR SEAM WELDED STRUCTURAL ASSEMBLIES.

Spot welded structural assemblies should best be repaired at the factory of origin or at a repair station rated for this type of work unless the repairs are to be accomplished by riveting, in which case the practices and procedures specified in the preceding sections should be employed.

18.647 CASTINGS.

Damaged castings should be replaced and not repaired unless the method of repair is specifically approved by a representative of the Civil Aeronautics Administration.

18.648 CORROSION PROTECTION.**18.6480 GENERAL CONSIDERATIONS.**

When unpainted alloys, except aluminum coated materials (Alclad) are used, protective coatings should normally be applied. A very important point should here be indicated; it may be considered an accepted fact that dry aluminum cannot corrode, and therefore if effective means are provided to prevent moisture from coming in contact with aluminum alloys, corrosion may be prevented.

18.6481 ANODIC TREATMENT AND PRIMING.

The results of tests and service experience have demonstrated that, in general, corrosion is most effectively prevented by anodic coating and detail shop priming *prior* to assembly of each individual part of the aircraft structure. This rule is not to be considered as altogether general for there are certain subassemblies, relatively far removed from immersion and salt spray conditions which, in service, have been found to perform satisfactorily when anodically coated and primed, after assembly. For the most severe conditions, however, protection in detail *before* assembly should be accepted as the general rule.

18.6482 ALUMINUM ALLOYS IN CONTACT WITH WOOD.

Aluminum alloy elements in intimate contact with wood must be thoroughly moisture-proofed to prevent corrosion. This may be effectively accomplished by priming the adjacent aluminum alloy part with one coat of zinc-chromate primer and then thoroughly painting the wood with one coat of zinc-chromate primer followed by two or more coats of moisture-proof paint (bakelite varnish).

18.6483 JOINTS BETWEEN DISSIMILAR METALS.

Joints between dissimilar metals should receive careful consideration. The best solution to prevent attack is to insulate properly and keep moisture away. Insulation by placing a thin gasket or fabric, aluminum foil, cellophane, or impregnated fabric between the two parts is not sufficient in the case of airplanes that operate from or over salt water. Water can bridge the insulation at the edges which results in electrolytic action, resulting in corrosion. Therefore, it is of prime importance in the case of seaplanes that the edges of the whole joint be sealed with a compound (bakelite varnish, zinc chromate or bituminous paste) to prevent the entrance of moisture. The following method has been used with success in the case of important structural fittings already riveted in place: sandblast the fitting and the adjacent metal lightly and then spray the whole area with aluminum, building up general fillets along all seams and around fastenings. Then finish the assembly with a zinc chromate primer and an external coating of standard aircraft paint.

- (a) *Bolts and rivets in joints of dissimilar metals or wood.* Precautions should be taken with steel bolts and rivets which pass through aluminum alloys or wood. In such cases, particularly along the shank, insulation as discussed in the preceding sentence is not practicable. This makes it doubly necessary at least in the case of seaplanes to keep water away by using compound in the joint, dipping the fastenings in primer before inserting, and where possible using insulating washers on the heads and nuts, and finally filleting all joints and around heads and nuts with compound before the final paint coats.

18.649 BAD PRACTICES NOT CONSIDERED ACCEPTABLE.

- (a) *Quenching in hot water or air.* The quenching of 17S or 24S alloys in water above 100° F. or air of any temperature after heat-treatment will not be satisfactory unless the material is in Alclad form, in which case air quenching is satisfactory. (Air temperature must be below 100° F.)
- (b) *Transferring too slowly from heat-treatment medium to quench tank.* Insufficiently rapid transfer of 175S or 24S alloys from the heat-treatment medium to the quench tank will not be considered good practice. (An elapsed time of 10 to 15 seconds will, in many cases result in noticeably impaired corrosion resistance.)
- (c) *Reheating at temperatures above boiling water.* Reheating at temperatures above that of boiling water of 17S or 24S alloys after heat-treatment, and the baking of primers at temperatures above that of boiling water will not be considered acceptable without subsequent complete and correct heat-treatment, as such practice tends to impair the original heat-treatment.
- (d) *Use of annealed alloys for structural parts.* The use of annealed 17S or 24S alloys for any structural repair of an aircraft where corrosion is likely to occur will not be considered satisfactory on account of poor corrosion resisting properties.
- (e) *Hygroscopic materials improperly moisture-proofed.* The use of hygroscopic materials improperly moisture-proofed such as impregnated fabrics, leather and the like, in attempting to effect watertightness of joints and seams will not be considered acceptable practice.
- (f) *The leaving of any trace of welding flux after welding.* The leaving of any trace of welding flux after welding will not be considered acceptable.
- (g) *Use of paint removers.* The use of paint removers which contain strong caustic compounds, and of so-called thin paint removers which may have a tendency to run into joints, rather than those which have a jellylike consistency, will not be considered satisfactory. Polishes and cleaners which have excessive abrasive action will be considered equally unsatisfactory. A suggested testing procedure for determining "safe" cleaners for aluminum acceptable to the Civil Aeronautics Administration will be found in the following:
1. *Tests for cleaners which are to be used in aqueous solutions.* Specimens about 3 inches by 0.75 inch by 0.064 inch thick of aluminum alloy of the type under consideration should be exposed at 80° C. for 5 hours to each of the following concentrations of the cleaner: 0.25, 0.50, 0.75, 1, 1.5, 2, 3, 5, 10, and 20 percent. For each specimen 50 cubic centimeters of solution should be used.
Some of the undiluted cleaner should be placed on other specimens which are stored in an atmosphere saturated with water vapor at 25° C. for 24 hours. In addition to the two tests described above, specimens should be cleaned following precisely the in-

structions furnished by the manufacturer of the cleaner. This cleaning operation is repeated *twenty* times.

If none of the specimens in the above three tests are discolored, etched or pitted, the cleaner will be considered "safe."

In the case of anodically coated material, the same procedure as outlined above should be followed.

2. *Polishes, abrasive cleaners, oily cleaners, etc.* Specimens of the aluminum alloy for which the cleaner is intended should be cleaned *twenty* times following the instructions furnished by the manufacturer of the cleaner in detail.

Some of the cleaner is also placed on additional specimens which are stored in an atmosphere saturated with water vapor at 25° C. for 24 hours. If the specimens are not discolored, etched or pitted, the polishing material will be considered "safe."

Furthermore, to be classified as completely safe, it must not abrade the aluminum alloy in question to an extent greater than No. 0 steel wool.

18.65 SAFETY BELT INSTALLATIONS.

Torn or otherwise damaged webbing should not be repaired but should be replaced.

In case replacement of webbing or hardware is attempted, the parts should be obtained from the original manufacturer of the belt and stitched with thread of the manufacturer's specifications. The stitch pattern should be identical to the original and the number of threads per inch should be equal to the number used by the manufacturer.

In the case of air carrier operators who have special facilities for repair work of this type, a repair procedure is given in Certificate and Inspection Division Release No. 24.

18.66 ELECTRICAL INSTALLATIONS.

18.660 CABLE INSULATION.

If the insulation of electrical cable is worn through or cracked through to the conductor at any point, the entire length of cable should be replaced with cable of at least the same quality.

18.661 CABLE TERMINALS.

Clean and retin cable terminals if they are dirty or have been scarred by lock-washers or nuts. They should be polished with very fine sandpaper or emery cloth and then be wiped with a clean cloth. If the cable insulation has become disconnected from the cable terminal the latter should be replaced. However, if the cable is not of sufficient length to permit the necessary piece to be cut off for replacement of the terminal, a new length of cable should be installed.

18.662 FUSE CLIPS.

If fuse clips are dirty, they should be cleaned. If they are distorted to the extent that they do not make good contact with the fuse ferrule, they should be replaced with new clips, because the case is rare in which a bent clip can be straightened so that it will make good contact.

18.663 RUBBER GROMMETS.

If the rubber in a grommet has lost its pliability the grommet should be replaced. If a grommet has been cut by the edges of the material in which it is installed, it should be replaced. There should be no pressure on a grommet other than from the dead weight of the cable or cables passing through it. If cables were drawn taut so that additional pressure was exerted on the grommet, the condition should be corrected in a suitable manner.

18.664 BATTERY CABLES.

If the rubber tubing installed over the cables connecting to the battery has lost its pliability or is damaged, it should be replaced.

18.67 AIRCRAFT ENGINES.**18.670 GENERAL.**

In repairing or overhauling aircraft engines, all repair agencies should be guided by the recommendations and procedures set forth in the respective instruction books, manuals, or service bulletins for the installation, inspection, and maintenance of aircraft engines, published by the aircraft engine manufacturers for each type of engine.

18.6700 ROTATING, RECIPROCATING, AND HIGHLY STRESSED STRUCTURAL UNITS.

The rotating, reciprocating, and highly stressed structural units of all aircraft engines should be subjected to a critical inspection at the time of overhaul. Whenever possible this inspection should be supplemented by a wet or dry magnetic dust inspection of the steel parts. In such a case, a copy of the report covering the findings of the magnetic dust inspection must be appended to the original Repair and Alteration Form in the case of a major repair.

18.671 CRANKSHAFTS.

Crankshafts should be carefully inspected for alinement.

Crankshafts that have been in aircraft that have nosed over and are bent beyond the manufacturer's permissible alinement limits should not be repaired but must be replaced.

18.672 REPLACEMENT PARTS IN CERTIFICATED AIRCRAFT ENGINES.

Only structural engine parts which are approved by the Civil Aeronautics Administration should be used in making replacements on certificated aircraft engines. Engine manufacturers consider that their engines have very few parts which should not be considered structural parts.

Copies of "Specifications" describing the structural aircraft engine parts of manufacturers other than the original manufacturer which are approved may be obtained by requesting them from the Chief, Correspondence Section, Civil Aeronautics Administration, Washington, D. C. These parts will be eligible for approval in accordance with Part 13 of the Civil Air Regulations.

However, the term "structural engine parts"¹⁵ does not include standard commercial parts of conventional materials such as minor gaskets, nuts, pins, safety wire, etc. These parts need not be approved if they are the equivalent of the engine manufacturer's parts.

18.673 RUN-IN TIME.

After an aircraft engine has been overhauled, it should be run-in in accordance with the pertinent aircraft engine manufacturer's instructions. If no special test stand, test club and equipment are available, the plane should be headed into the wind during the run-in on the ground so that maximum cooling effect will be obtained. Proper cooling during run-in cannot be over-emphasized. The manufacturer's recommendations concerning permissible head, barrel and oil temperatures should be carefully observed.

18.674 COTTER-PINS, WRIST-PIN RETAINERS, AND SAFETY WIRE.

Cotter-pins and safety wire should never be used a second time. The usual type of wrist-pin retainer likewise should be replaced but special coil spring

¹⁵ An inspector of the Civil Aeronautics Administration should be consulted concerning any doubtful cases.

retainers need not be replaced if this replacement is not recommended by the pertinent aircraft engine manufacturer. Other safetying devices including bolts and nuts which have been bent or worn must always be replaced with new parts.

18.675 WELDING IN THE REPAIR OF ENGINES.

18.6750 STRUCTURAL PARTS.

Welding should not be done on any structural part of an aircraft engine except when it is proved conclusively to the Civil Aeronautics Administration that the repaired part is as airworthy as the original. In any event, when welding is done, the procedure specified in the following paragraph must be followed.

18.6751 SECONDARY PARTS.

Minor parts not subjected to high stress may be repaired by welding provided the welded parts are stress-relieved or reheat-treated after welding in a heat-treating furnace with precision heat control. Minor parts suitable for such a repair are usually those damaged by assembly or disassembly as well as those damaged by contact with a foreign object. Brackets, spacers, covers and mounting pads fall in this category. All aircraft engine parts are usually heat-treated during manufacture. Therefore, any welding tends to impair the strength of material adjacent to the weld and it is not possible to restore the original strength by heat-treatment after welding.

18.676 METALLIZING.

Metallizing should not be done on any internal part of an aircraft engine except when it is proved conclusively to the Civil Aeronautics Administration that the metallized part will not adversely affect the airworthiness of the engine. Metallizing may be accomplished on the external part of the engine if the aircraft engine manufacturer has no objection to this practice.

18.677 CORROSION PREVENTION.

The use of strong solutions which contain strong caustic compounds and of all solutions, polishers, cleaners, abrasives, etc., which have an adverse effect on the airworthiness of the engine due to corrosive action will not be considered satisfactory.

18.678 ENGINE ACCESSORIES.

The engine accessories should be overhauled and repaired in accordance with the recommendations of the manufacturer of the accessories involved.

18.68 AIRCRAFT PROPELLERS.

18.680 HOLLOW AND SOLID STEEL PROPELLERS.

Damaged steel propeller blades should not be repaired except by the manufacturer. Welding or straightening will not be permissible on such blades even for very minor repairs except by the manufacturer, due to the special process employed and the heat-treatment required. A blade developing a crack of any nature in service should be returned to the manufacturer for inspection. When a blade is considered nonrepairable, a notice of rejection should be made out by the manufacturer and sent to the nearest inspector of the Civil Aeronautics Administration.

18.6800 REPAIR OF MINOR DAMAGE.

Minor injuries to the leading and trailing edges only of steel blades may be smoothed by hand stoning provided the injury is not deep.

18.681 ALUMINUM ALLOY PROPELLERS.

A seriously damaged aluminum alloy propeller blade should be repaired only by the manufacturer or by repair agencies certificated for this type of work. Such repair agencies should be governed by the following considerations.

18.682 DEFINITION OF DAMAGED PROPELLERS.

A damaged metal propeller is one which has been bent, cracked, or seriously dented. Minor surface dents, scars, nicks, etc., which are removable by field personnel are not considered sufficient to constitute a damaged propeller.

18.6820 REPAIRABLE BLADES.

Damaged blades with model numbers which are on the manufacturer's list of blades that cannot be repaired should be rejected.

18.6821 BLADES BENT IN FACE ALINEMENT.

The extent of a bend in the face alinement of blades should be carefully checked by means of a protractor similar to the one illustrated in figure 37. Only bends not exceeding 20° at 0.15 inch blade thickness to 0° at 1.1 inch blade thickness may be cold straightened. After straightening, the affected portion of the blade should be etched and thoroughly inspected for cracks and other flaws. Blades with bends in excess of this amount require heat treatment and should be returned to the manufacturer or his authorized agent for repair.

18.6822 BLADES BENT IN EDGE ALINEMENT.

Blades which are bent in edge alinement should not be repaired by anyone except the manufacturer or a certificated repair station holding the appropriate rating.

18.6823 INSPECTION AND TREATMENT OF DEFECTS.

Scratches and suspected cracks should be given a local etch as outlined in CAM 14 and examined with a magnifying glass. The shank fillets of adjustable pitch blades and the front half of the under surface of all blades from 6 to 10 inches from the tip are the most critical portions. Adjustable pitch blades should also be etched locally on the clamping portion of the shank at points ¼ inch in from the hub edge in line with the leading and trailing edges, and examined with a magnifying glass for circumferential cracks. The shank must be within drawing tolerance. Any crack is cause for rejection. The micarta shank bearing on controllable and hydromatic propeller blades should not be disturbed except by the manufacturer. Blades requiring removal of more material than permissible as specified in section 18.6827 should be scrapped.

18.6824 LOCAL ETCHING.

To avoid dressing off an excess amount of metal, checking by local etching (CAM 14) should be accomplished at intervals during the progress of removing cracks and double-back edges of metal. Suitable sandpaper or fine cut files may be used for removing the necessary amount of metal, after which, in each case, the surfaces involved should be smoothly finished with No. 00 sandpaper. Each blade from which any appreciable amount of metal has been removed should be properly balanced before it is used.

18.6825 TREATMENT OF MINOR SURFACE DEFECTS.

Dents, cuts, scars, scratches, nicks, etc., should be removed or otherwise treated as explained below, provided their removal or treatment does not materially weaken the blade, materially reduce its weight, or materially impair its performance. The metal around longitudinal surface cracks, narrow cuts, and shallow scratches should be removed to form shallow saucer shaped depressions as shown in figure 38 (view C). Blades requiring the removal of metal forming a finished depression more than ⅛ inch in depth at its deepest point, ⅜ inch in width over-all, and 1 inch in length

over-all should be rendered unserviceable or a notice of rejection supplied to the nearest inspector of the Civil Aeronautics Administration.

(a) *Treatment of metal at edges of defects.* The metal at the edges of wide scars, cuts, nicks, etc., should be rounded off and the surfaces within the edges should be smoothed out as shown in figure 38 (view B). Blades that require the removal of metal to a depth of more than $\frac{1}{8}$ inch and a length of more than $\frac{1}{4}$ inch over-all should be rendered unserviceable or a notice of rejection supplied to the nearest inspector of the Civil Aeronautics Administration.

(b) *Treatment of raised edges of scars.* Raised edges at wide scars, cuts, nicks, etc., should be carefully smoothed to reduce the area of the defect and the amount of metal to be removed as shown in figure 38 (view A). It is not permissible to peen down the edges of any defect. With the exception of cracks, it is not necessary to completely remove or "saucer out" all of a comparatively deep defect. Properly rounding off the edges and smoothing out the surface within the edges is sufficient, as it is essential that no unnecessary amount of metal be removed.

18.6826 NUMBER OF DEFECTS ALLOWABLE IN BLADES.

More than one defect falling within the above limitations is not sufficient cause alone for rejection of a blade. A reasonable number of such defects per blade is not necessarily dangerous, if within the limits specified, unless their location with respect to each other is such as to form a continuous line of defects that would materially weaken the blade.

18.6827 REPAIR OF PITTED LEADING EDGES.

Blades that have the leading edges pitted from normal wear in service may be reworked by removing sufficient material to eliminate the defects. In this case, the metal should be removed by starting at approximately the thickest section, as shown in figure 39; and working forward over the nose camber so that the contour of the reworked portion will remain substantially the same, avoiding abrupt changes in section or blunt edges. Blades requiring removal of more material than the permissible reduction in width and thickness from the minimum drawing dimensions should be rejected.

For repair blades the permissible reductions in width and thickness from minimum original dimensions allowed by the blade drawing and blade manufacturing specification are shown in figure 40 for locations on the blade from the shank to 90 percent of the blade radius. The outer 10 percent of blade length may be modified as required.

The following tolerances are those listed in the blade manufacturing specification and govern the width and thickness of new blades. These tolerances are to be used with the pertinent blade drawing to determine the minimum original blade dimensions to which the reductions of figure 41 may be applied.

	<i>Manufacturing tolerance (inch)</i>
Basic diameter less than 10 feet 6 inches:	
Blade width—from shank to 24-inch station	$\pm \frac{1}{4}$
from 30-inch station to tip	$\pm \frac{1}{2}$
Blade thickness	± 0.025
Basic diameter 10 feet 6 inches to less than 14 feet 0 inches:	
Blade width—from shank to 24-inch station	$\pm \frac{1}{16}$
from 30-inch station to tip	$\pm \frac{1}{2}$
Blade thickness—from shank to 24-inch station	± 0.030
from 30-inch station to tip	± 0.025
Basic diameter 14 feet and 0 inches over:	
Blade width—from shank to 30-inch station	$\pm \frac{3}{32}$
from 36-inch station to tip	$\pm \frac{1}{16}$
Blade thickness—from shank to 30-inch station	± 0.040
from 36-inch station to tip	± 0.035

18.6828 SHORTENING OF BLADES DUE TO DEFECTS.

When the removal or treatment of defects on the tip necessitates shortening a blade, each blade used with it should likewise be shortened. Such sets of blades should be kept together. (See fig. 41 for acceptable method.)

18.683 CAUSES FOR REJECTION.

Unless otherwise specified herein, a blade having any of the following defects should be rendered unserviceable or a notice of rejection sent to the nearest inspector of the Civil Aeronautics Administration.

- (a) *Irreparable defects.* A longitudinal crack, cut, scratch, scar, etc., that cannot be dressed off or rounded out without materially weakening or unbalancing the blade or materially impairing its performance.
- (b) *General unserviceability.* Unserviceability due to removal of too much stock by etching, dressing off defects, etc.
- (c) *Slag inclusions.* An excessive number of slag inclusions or cold shuts or an excessive number of both.
- (d) *Transverse cracks.* A transverse crack of any size.

18.684 BALANCE.

Horizontal and vertical unbalance should be corrected as outlined in CAM 14.

18.685 WOOD PROPELLERS.

Wood propellers should be inspected for such defects as cracks, bruises, scars, warp, oversize holes in the hub, evidence of glue failure and separated laminations, sections broken off and defects in the finish. The tipping should be inspected for such defects as looseness or slipping, separation of soldered joints, loose screws, loose rivets, breaks, cracks, eroded sections, and corrosion.

18.6850. CAUSES FOR REJECTION.

A wood propeller damaged to the following extent should be scrapped:

- (a) A crack or deep cut across the grain of the wood.
- (b) A comparatively long, wide, or deep cut parallel to the grain of the wood.
- (c) A separated lamination.
- (d) An excessive number of screw or rivet holes.
- (e) An oversize hub or bolt hole, or elongated bolt holes. (The plugging and reboring of bolt holes is not permissible.)
- (f) An appreciable warp.
- (g) An appreciable portion of wood missing.
- (h) A crack, cut, or damage to the metal shank of adjustable pitch wood blades.

18.6851 REPAIR OF SMALL CRACKS AND CUTS.

Small cracks parallel to the grain of the wood should be filled with glue thoroughly worked into all portions of the cracks, dried and then sanded smooth and flush with the surface of the propeller. This also applies to small cuts.

18.6852 REPAIR OF DENTS OR SCARS.

Appreciable dents or scars which have rough surfaces or shapes that will hold a filler and will not induce failure, may be filled with a mixture of casein glue and clean, fine sawdust thoroughly worked and packed into the defect, dried and then sanded smooth and flush with the surface of the propeller. In any case, all loose splinters should be removed.

18.6853 USE OF INLAYS.

Inlays as shown in figure 42 of this manual may be used. The following considerations should apply:

- (a) *Materials to be used.* Inlays should be of the same wood as the propeller blade (i. e., a yellow birch propeller should be inlaid with yellow

birch not with white birch), and as near the same specific gravity as possible.

- (b) *Preparation of joint.* Repair joints should conform with figure 42 for taper of 10/1 from deepest point to feather edge or end of inlay. Measurements are taken along a straight line parallel to the grain or general slope of the surface on thrust and cambered faced. This rule applies also to the edge repairs.
- (c) *Exterior protection of repairs.* All hidden repairs should have not less than two uncut coats of high grade exterior spar varnish before being covered by the metal tipping.
- (d) *Repairs not to be covered with fabric or stain.* Repairs not under metal tipping should not be covered with fabric or have the wood stained to the extent of hiding the repairs.
- (e) *Direction of grains in inlays.* The grain of inlays should extend in the same direction as the grain of the propeller laminations.
- (f) *Dovetail type inlays.* Dovetail type inlays should not be used.
- (g) *Number of inlays.* The number of inlays should not exceed one large, two medium, or four small widely separated inlays per blade. A trailing and a leading edge inlay should not overlap more than 25 percent as shown in figure 42.

18.6854 HUB, NECK, AND SHANK REPAIRS.

NOTE.—The following divisions refer to propellers for the same engine horsepower and hub. (See fig. 43.)

- (a) *Small hub diameter, heavy necks and shanks.*
 - (1) *Hub.* Only the smallest of inlays should be used where there is any question of affecting the strength.
 - (2) *Neck and shank.* These are proportionately large in cross-section and fairly large repairs are possible, limited to a depth of about 5 percent of the section thickness.
- (b) *Small to medium diameter hub with excessively small necks and shanks.*
 - (1) *Hub.* Only the smallest of inlays should be used where there is any question of affecting the strength.
 - (2) *Neck and shank.* In the small shank area for propellers under 50 horsepower, cuts 5 percent deep may be filled with glue and sawdust. Over 50 horsepower, no inlay repairs should be made deeper than 2½ percent.
- (c) *Large hub diameter, heavy necks and shanks.*
 - (1) *Large inlays.* Fairly large inlays are permissible on edges of hubs where cap laminations have crushed edges.
 - (2) *Shank inlays.* Shank inlays should not exceed 7½ percent thickness of section for the heavy shanks, or 5 percent for the proportionately lighter shanks.
 - (3) *Hub face replacement.* Front and rear hub face replacements should total a thickness not to exceed 5 percent of the specified hub thickness.

18.6855 BLADE REPAIRS.

On blades with normal sections from the midsection to the tip, a cross-grain cut, up to 20 percent of the chord in length and one-eighth of the section thickness at the deepest point of damage may be repaired. (See fig. 42.) On blades with thin sections this depth should not exceed one-twentieth of the section thickness.

- (a) *Exception.* No repairs of the above kind should be made on either face when the feather edge of the cross grain cut is closer than 2 inches to the inner edge of the metal tip.
- (b) *Trailing edge repairs.* Narrow slivers up to $\frac{1}{8}$ -inch wide broken from the trailing edge at the wider portions of the blade may be repaired by sandpapering a new trailing edge, removing the least material possible, and fairing in a new trailing edge of smooth contour. Both blades should be narrowed by the same amount.
- (c) *Repair near hub or tip.* Near the hub or tip an inlay should be used, and should not exceed at its greatest depth 5 percent of the chord. The permanency of the joint, butt, scarf, or fishmouth is in the order named, the fishmouth being the most preferable.
- (d) *Repairs at end of metal tipping.* In order to replace the wood worn away at the end of the metal tipping, enough of the metal should be removed to make the minimum repair taper 10/1 each way from the deepest point. Due to the convex leading edge of the average propeller, this taper usually works out 8/1.
- (e) *Repairs under metal tipping.* Repairs under the metal tipping should not exceed $7\frac{1}{2}$ percent of the chord for butt or scarf joints, and 10 percent for fishmouth joints, with $\frac{3}{4}$ inch maximum depth for any repair.
- (f) *Finish.* The finish, where necessary, should be renewed in accordance with the recommendations of the manufacturer, but in all cases should be transparent (CAM 14).
- (g) *Tipping.* Tipping should be replaced when it cannot be properly repaired. Cracks in the narrow necks of metal between pairs of lobes of the tipping are to be expected and are not defects. All other cracks are defects that should be repaired, or eliminated by new tipping. Tipping should be attached as outlined in CAM 14.
- (h) *Horizontal and vertical unbalance.* Horizontal and vertical unbalance should be corrected as outlined in CAM 14.

18.686 PROPELLER HUBS.

Repairs to propeller hubs of certificated propellers should be made in accordance with the propeller manufacturer's recommended and approved tolerances whenever this is possible, or in accordance with the following considerations. Welding will not be permissible on steel hubs.

18.6860 REPLACEMENT OF SMALL STANDARD PARTS.

Clevis pins, bolts, and nuts should be replaced if they show any indication of wear or distortion. Cotter pins and safety wire should never be used a second time.

18.6861 GENERAL INSPECTION OF HUBS AND CLAMP RINGS.

Hubs and clamp rings should be cleaned in accordance with the manufacturer's recommended practice. They should be dimensionally inspected for conformity to the drawing. Particular care should be taken to check the 90° relation between shaft bore and blade socket centerline and track of the blade sockets, as these are the dimensions which are most likely to be affected by accidents. **ANY HUB WHICH IS SPRUNG SHOULD BE REJECTED.**

18.6862 MAGNETIC DUST INSPECTION.

Steel hubs should be minutely inspected for cracks by the wet or dry magnetic dust method (Magnaflux) at every major overhaul period regardless of the repair classification (minor or major repair). It is not necessary to remove the plating or special external finish for this inspection unless so specified in the manufacturer's recommended practice. A brief statement recording the

inspection and its findings should be included in the aircraft logbook entry. A similar entry in the repair records of the repair base, in the case of a carrier aircraft, is considered the equivalent of the logbook entry. An X-ray examination when conducted by a laboratory specializing in radiographic examinations is considered satisfactory in lieu of a magnetic dust inspection. Particular attention should be paid to the inside in the region of the shear shoulders of a hub. (Cracks usually start in line with the leading and trailing edges of the blade.) **ANY CRACK IS CAUSE FOR REJECTION.**

18.6863 FINISH OF HUBS AND CLAMP RINGS.

Hubs and clamp rings should be cadmium plated after they pass inspection. This plating should be done in accordance with the manufacturer's recommended practice. The use of zinc chromate primer on the external surfaces followed by a coating of aluminum lacquer in lieu of cadmium plating is considered equally acceptable.

18.6864 INSPECTION OF SPLINES AND CONE SEATS.

Splines and cone seats should be carefully inspected for signs of wear. Splines should be checked with a single key no-go gage made to plus 0.002 of the base drawing dimensions for spline land width. If the gage enters more than 20 percent of the spline area, the **HUB SHOULD BE REJECTED** and the local inspector notified.

18.687 PROPELLER GOVERNORS.

Repairs to governors used to control the operation of certificated propellers should be made in accordance with the propeller manufacturer's recommended practice. All replacement parts should be identical parts produced by the original manufacturer or parts approved by a representative of the Civil Aeronautics Administration. Welding will not be permissible on governor parts. After repair, a propeller governor should be tested as recommended by the manufacturer.

18.69 INSTRUMENTS.

18.690 GENERAL.

All repairs to instruments should be made in accordance with the instrument manufacturer's recommendations covering the installation, inspection, and maintenance of these units. If feasible, the general repair practices as outlined in the preceding paragraphs of this manual should be applied.

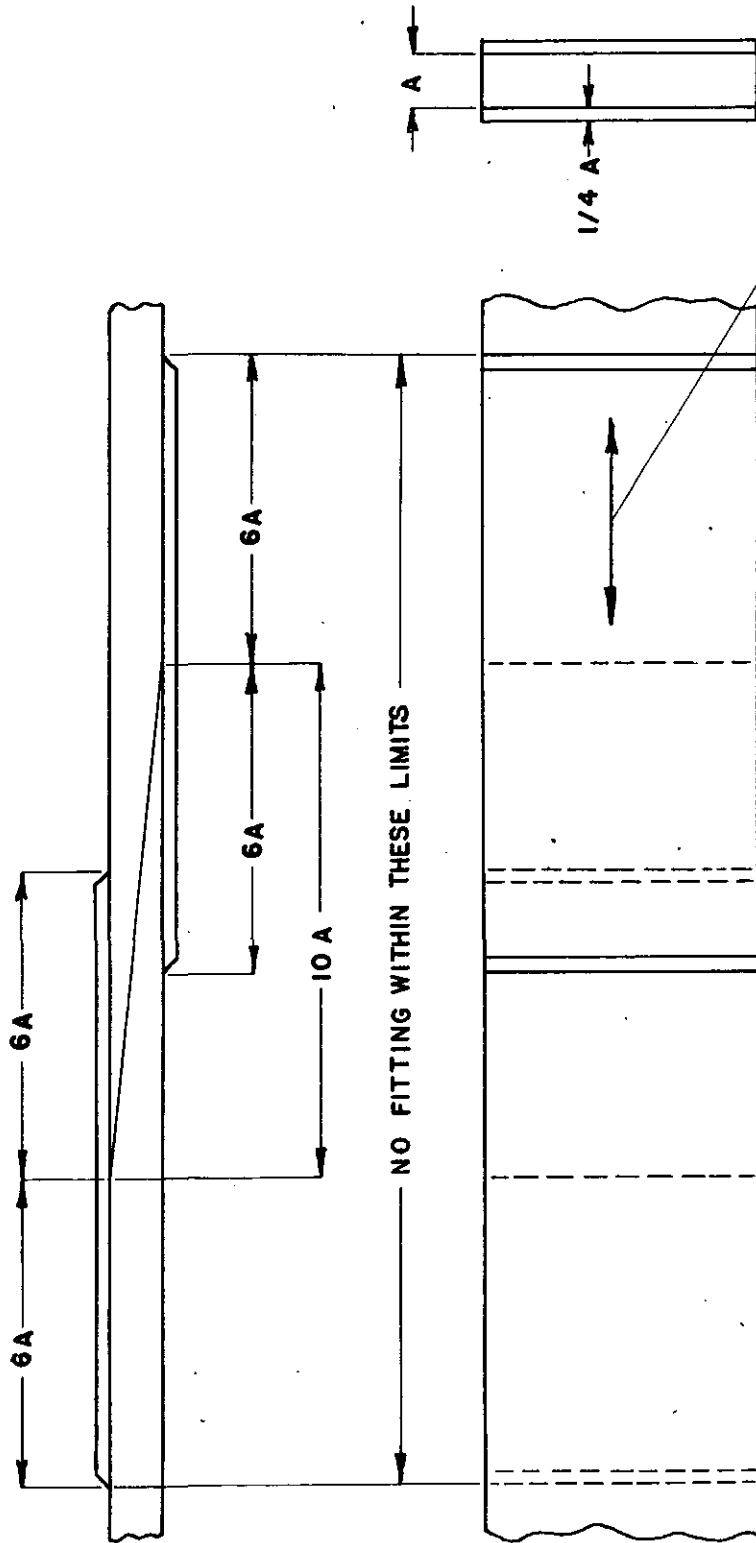

**DIRECTION OF GRAIN IF SPRUCE
OR OUTER FACE GRAIN IF PLYWOOD**

REINFORCING PLATES TO BE SPRUCE OR PLYWOOD AND SHALL BE GLUED ONLY.
SOLID SPARS MAY BE REPLACED WITH LAMINATED ONES OR VICE VERSA, PROVIDED THE
MATERIAL IS OF THE SAME HIGH QUALITY.

FIG. 1 — METHOD OF SPLICING SOLID OR LAMINATED RECTANGULAR SPARS.

Reference - Section 18.6011

IF SPLICE IS MADE WHERE ROUTING IS FEATHERED TO FULL WIDTH OF SPAR, TAPERED PLATES CONFORMING TO THE CONTOUR OF THE ROUTING, SHOULD FIRST BE ADDED, OTHERWISE THE SPLICE IS THE SAME AS SHOWN.

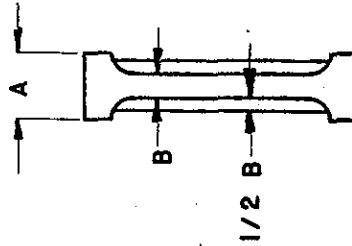
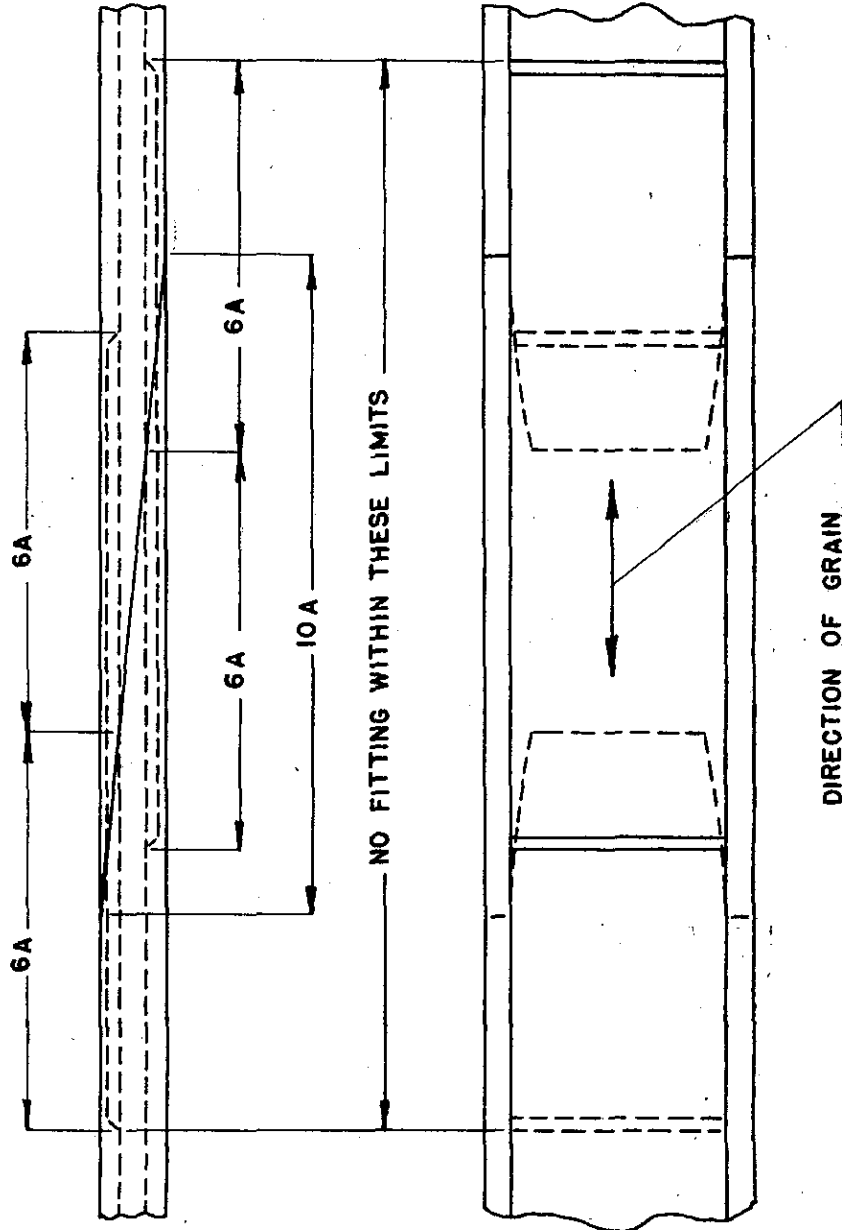

REINFORCING PLATES TO BE SPRUCE AND SHALL BE GLUED ONLY.

FIG. 2 -- METHOD OF SPLICING SOLID " I " SPARS.

Reference - Section 18.6011

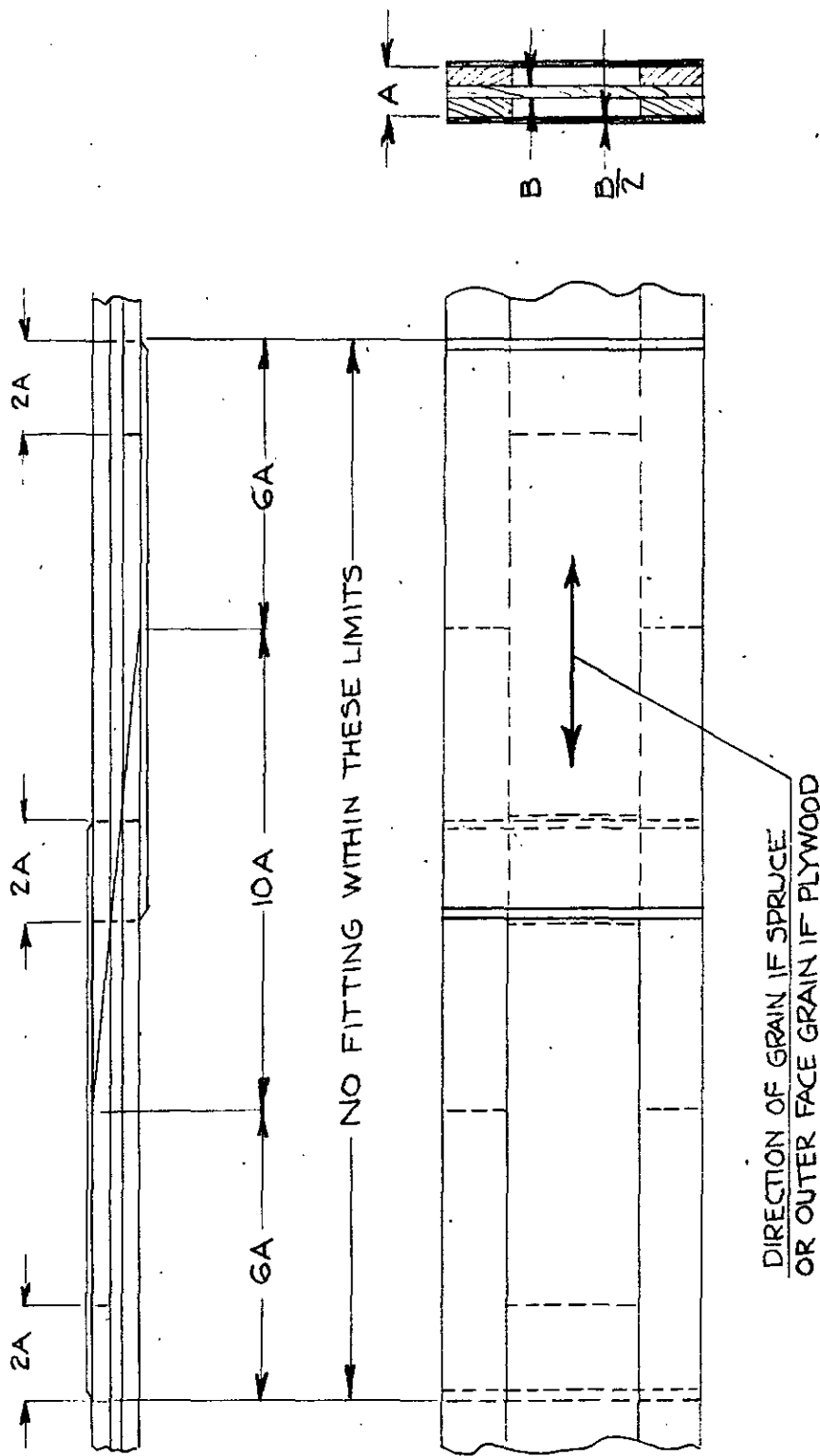
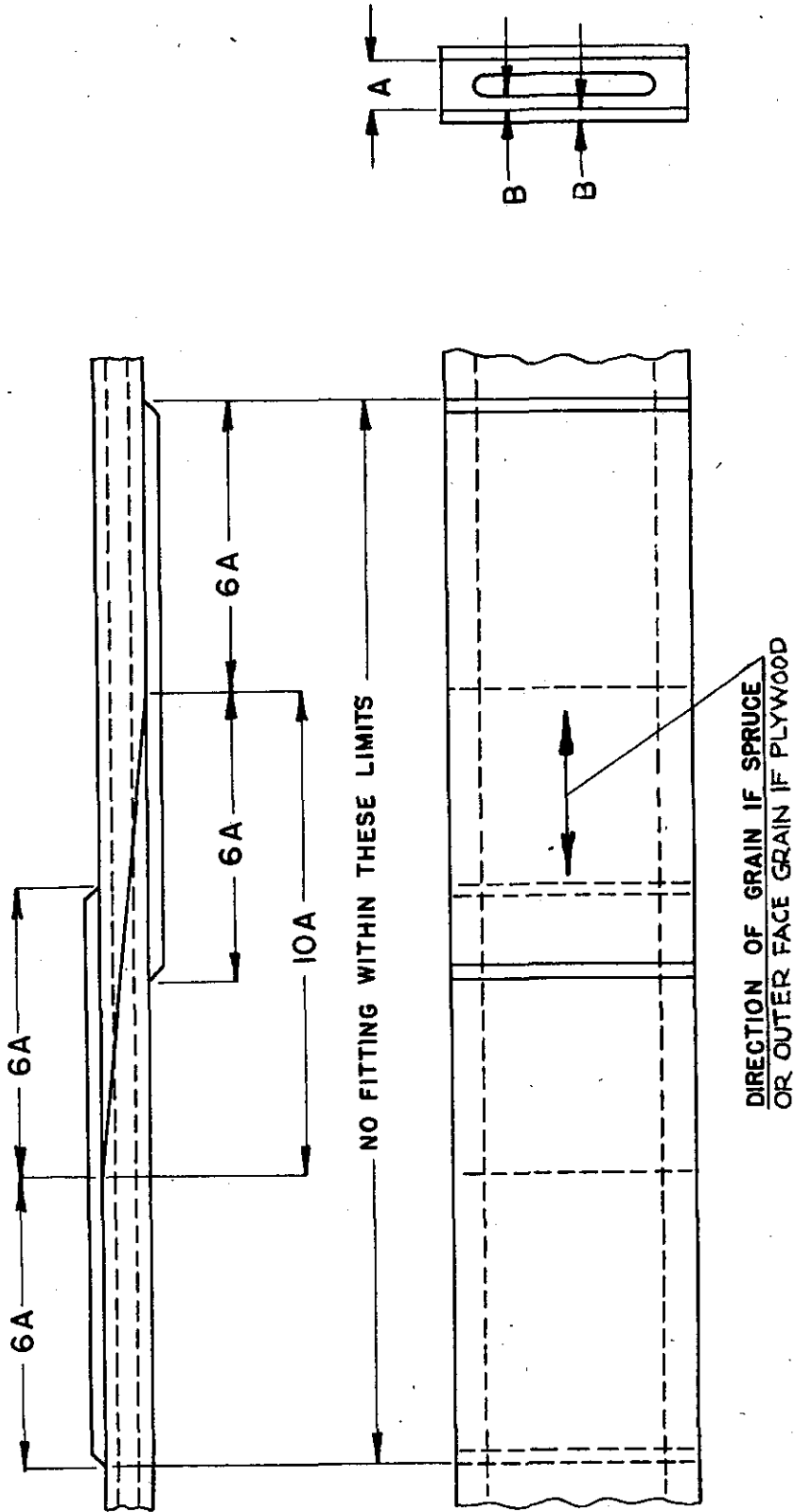

FIG. 3 - METHOD OF SPLICING "BUILT-UP-I" SPARS.

Reference - Section 18.6011



REINFORCING PLATES SHALL BE SPRUCE OR PLYWOOD AND SHALL BE GLUED ONLY.

FIG. 4 - METHOD OF SPLICING INTERNALLY ROUTED SPARS.

Reference - Section 18.6011

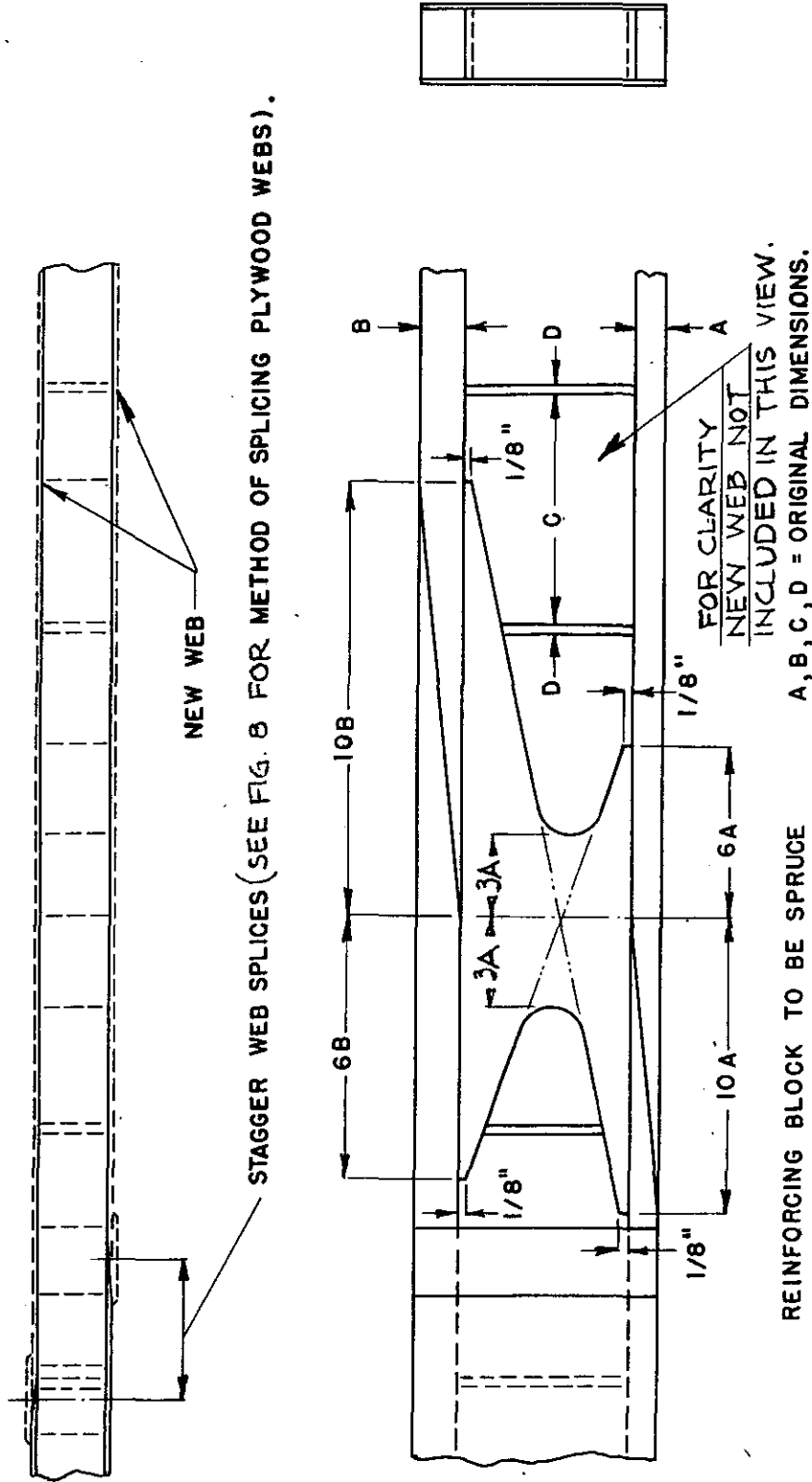

FIG. 5 - METHOD OF SPLICING BOX SPAR FLANGES (SOLID BLOCK METHOD).

Reference - Section 18.6011

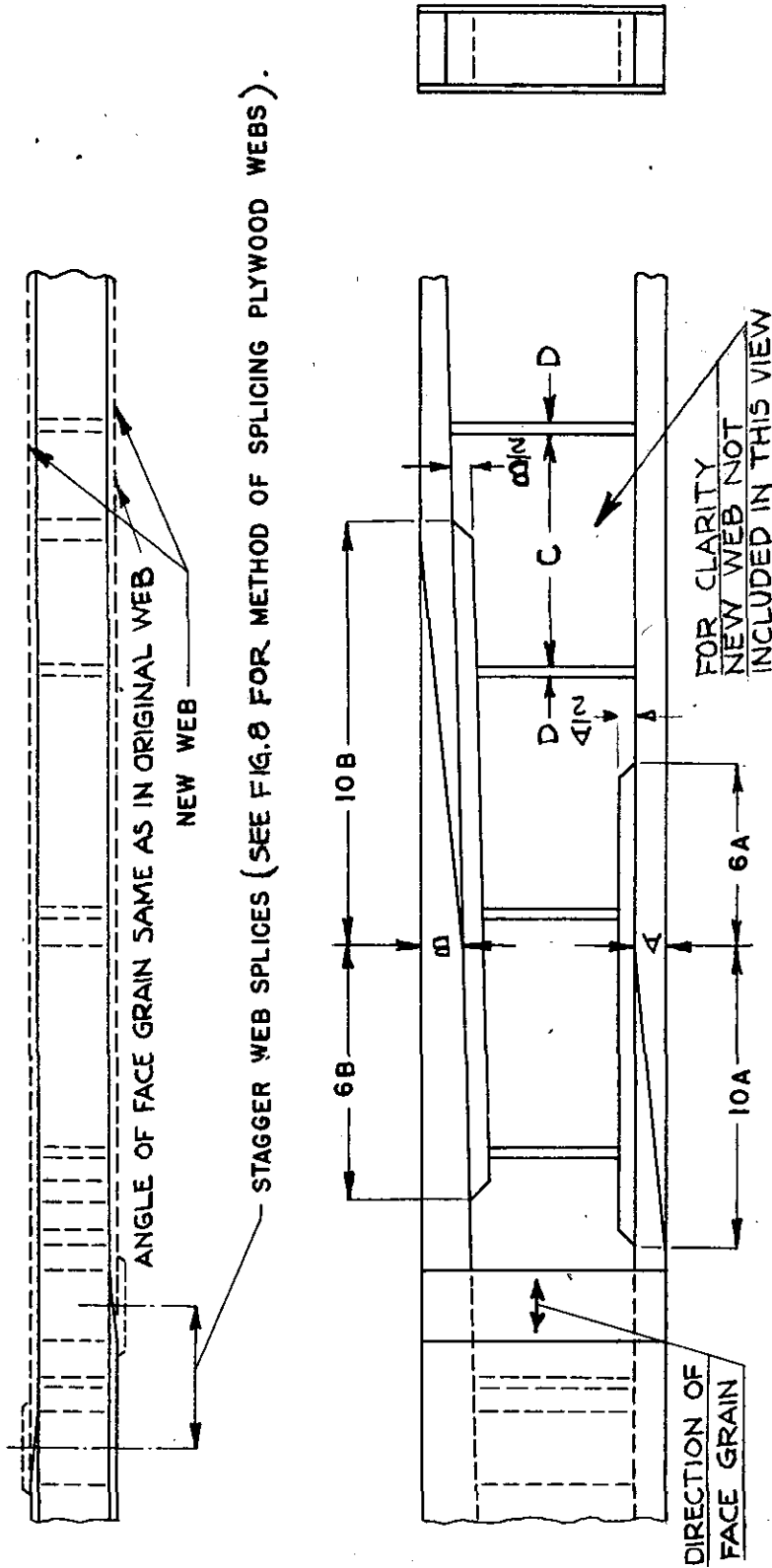

FIG. 6 - METHOD OF SPLICING BOX SPAR FLANGES (PLATE METHOD).

Reference - Section 18,6011

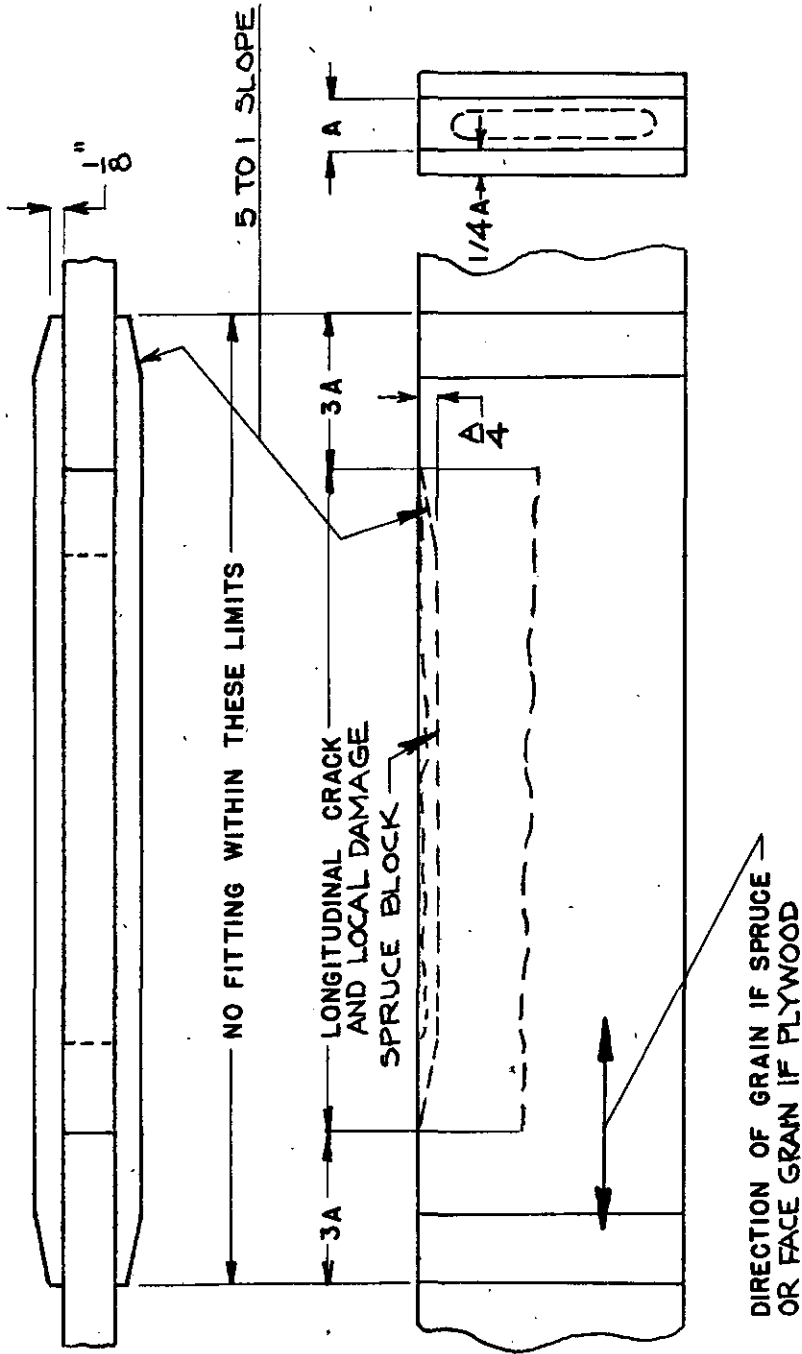
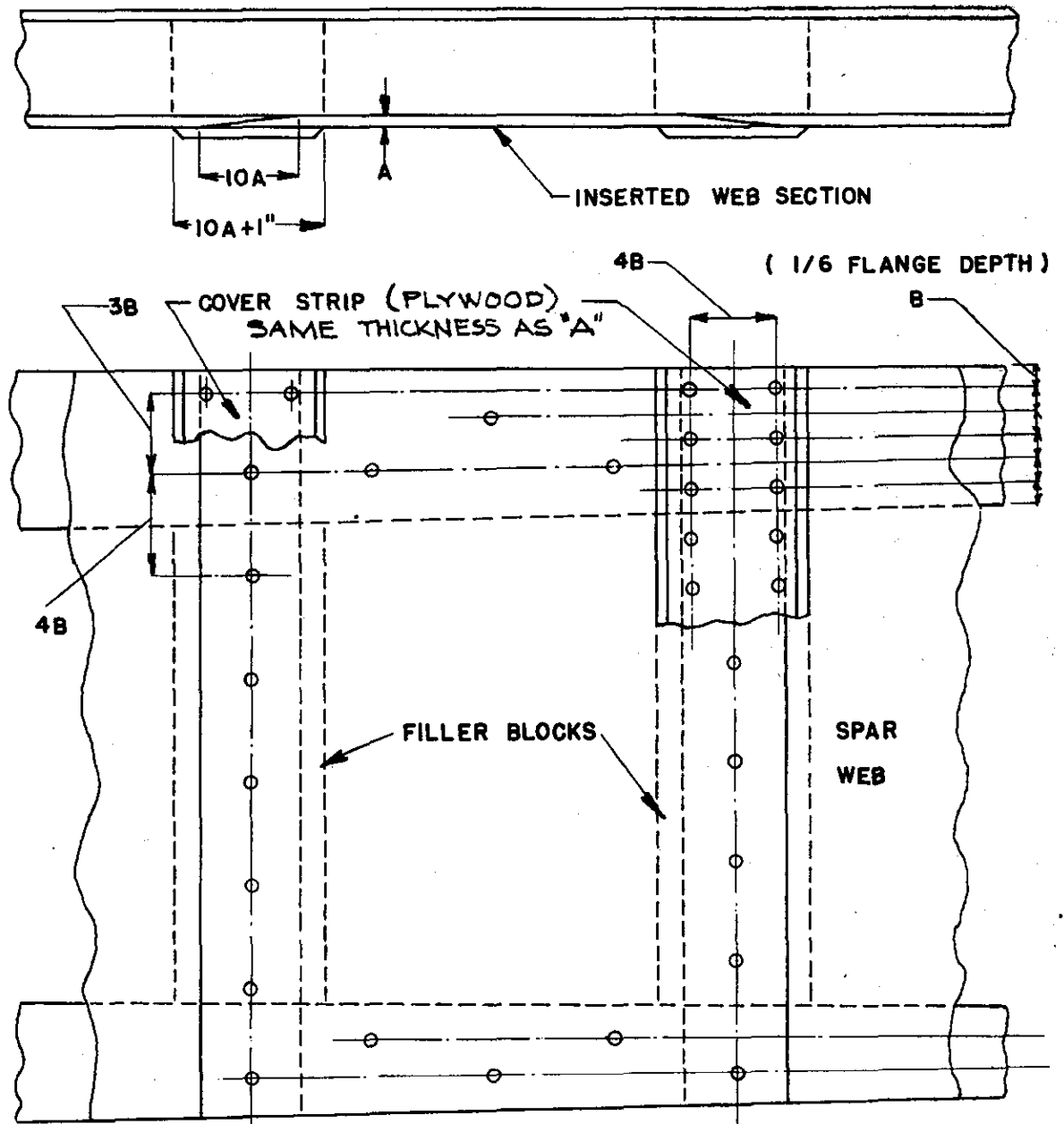

FIG. 7 -- METHOD OF REINFORCING A LONGITUDINAL CRACK AND/OR LOCAL DAMAGE IN A SOLID OR INTERNALLY ROUTED SPAR.

Reference - Section 18.6013



1. AFTER INSERTED WEB HAS BEEN GLUED AND NAILED IN PLACE, GLUE AND NAIL COVER STRIP OVER ENTIRE LENGTH OF SPLICE JOINTS.

2. SECTIONAL SHAPE OF FILLER BLOCKS MUST CONFORM EXACTLY TO TAPER OF SPAR. THEY MUST NOT BE TOO TIGHTLY FITTED OR WEDGING ACTION WILL LOOSEN EXISTING GLUE JOINTS OF WEBS TO FLANGES. IF TOO LOOSELY FITTED, CRUSHING OF WEB WILL OCCUR WHEN CLAMPING.

FIG. 8 — METHOD OF SPLICING BOX SPAR WEBS.

Reference - Section 18.6011

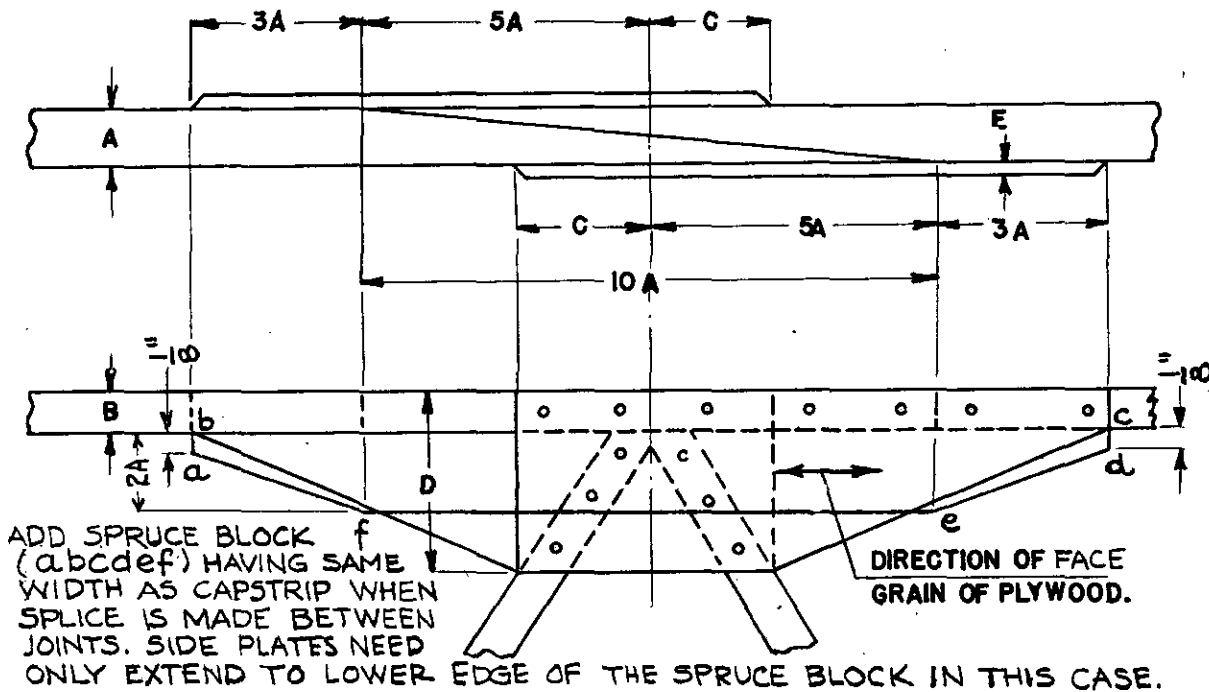

ADD SPRUCE BLOCK f (abcdef) HAVING SAME WIDTH AS CAPSTRIP WHEN SPLICE IS MADE BETWEEN JOINTS. SIDE PLATES NEED ONLY EXTEND TO LOWER EDGE OF THE SPRUCE BLOCK IN THIS CASE.

A, B, C, D, E = ORIGINAL DIMENSIONS.
 REINFORCEMENT PLATES SHALL BE PLYWOOD GLUED AND NAILED.
 NAIL HEADS SHALL NOT BE IMBEDDED IN THE PLYWOOD.
 DAMAGED WEB MEMBERS SHALL BE REPLACED ENTIRELY.

(A) AT A JOINT OR BETWEEN JOINTS.

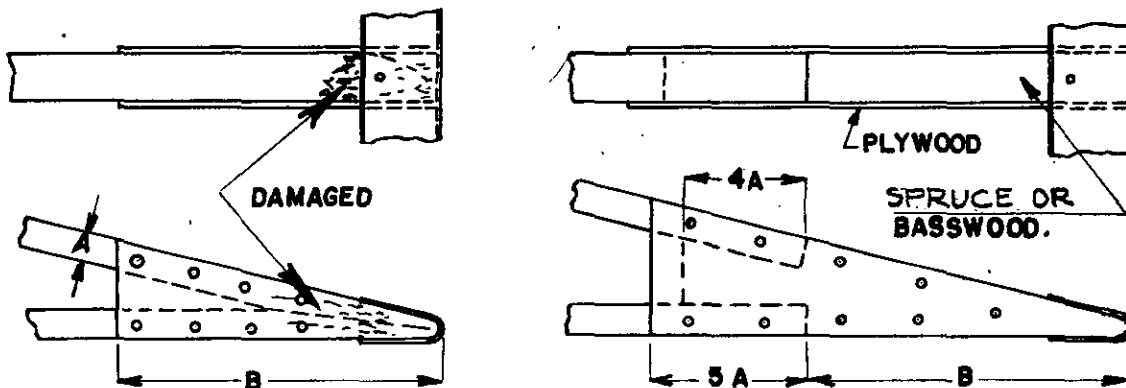

(B) AT TRAILING EDGE.

FIG. 9 — TYPICAL WOODEN WING RIB REPAIRS.

Reference - Section 19.6016

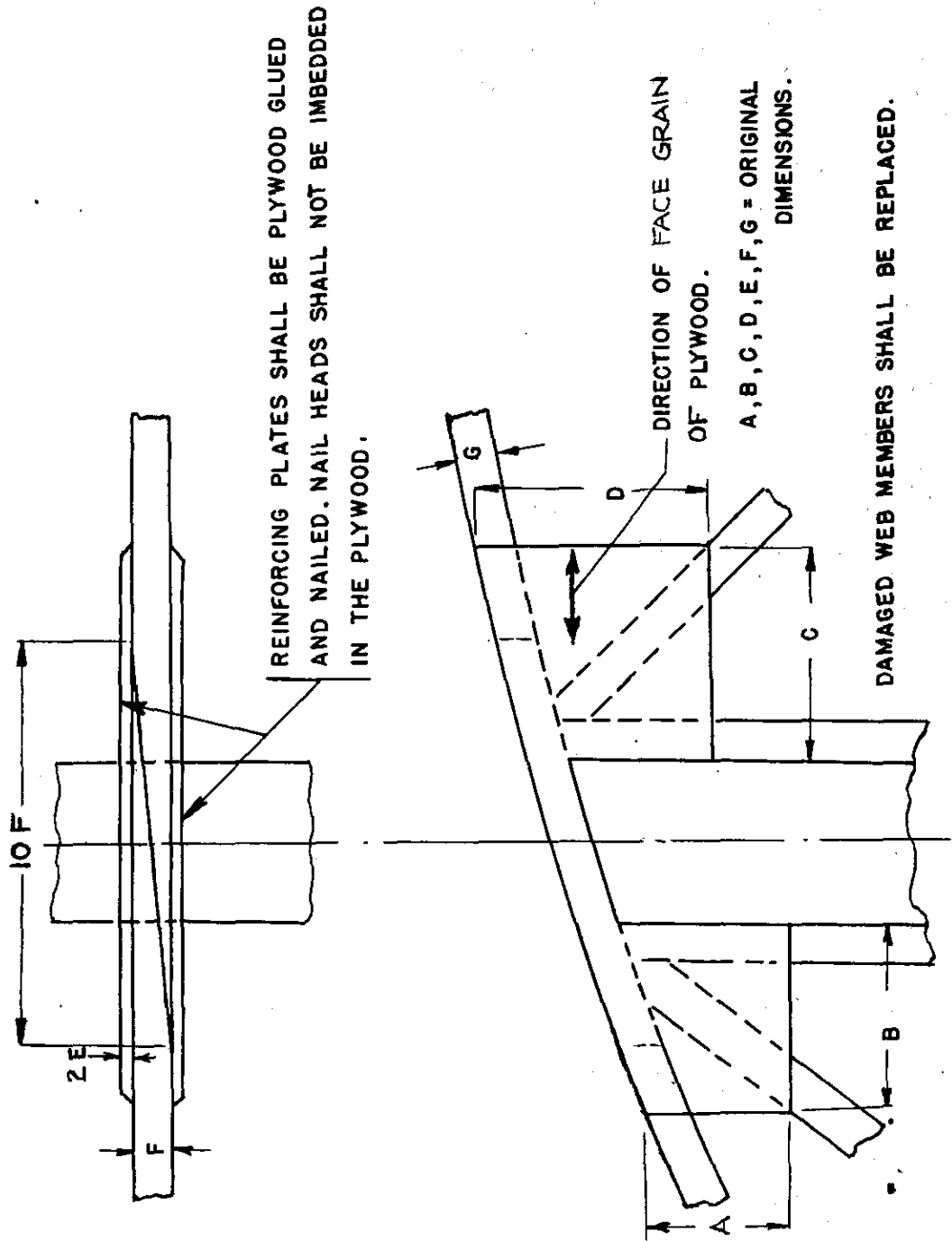

FIG.10 - TYPICAL RIB SPLICE AT A SPAR.

Reference - Section 18.6016

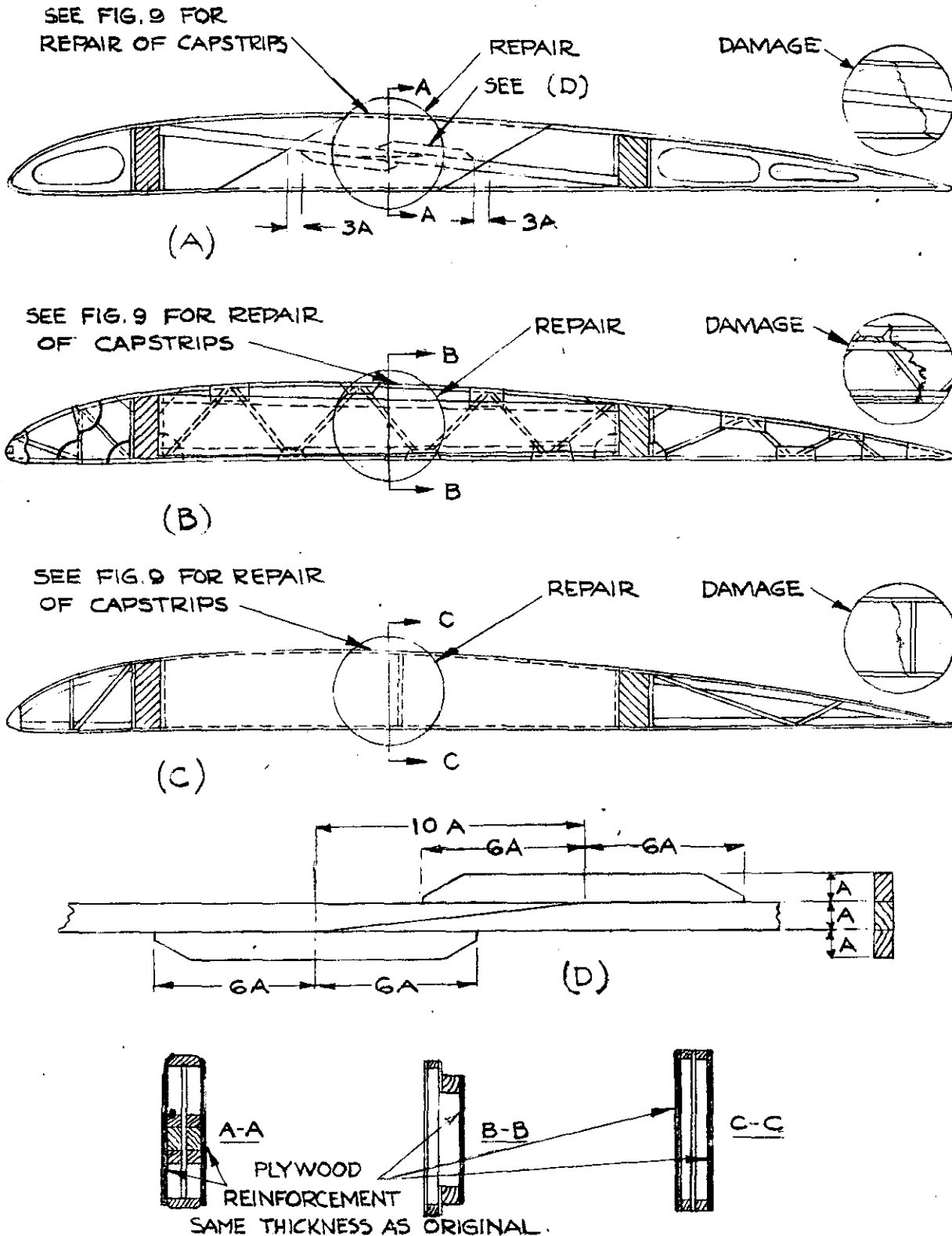
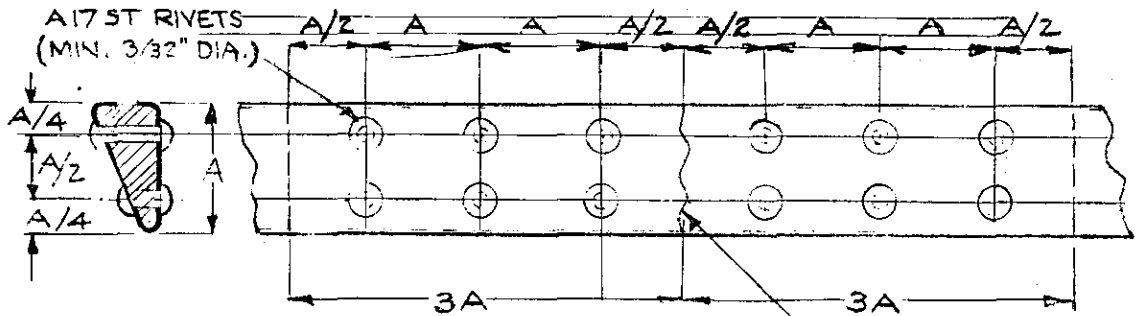
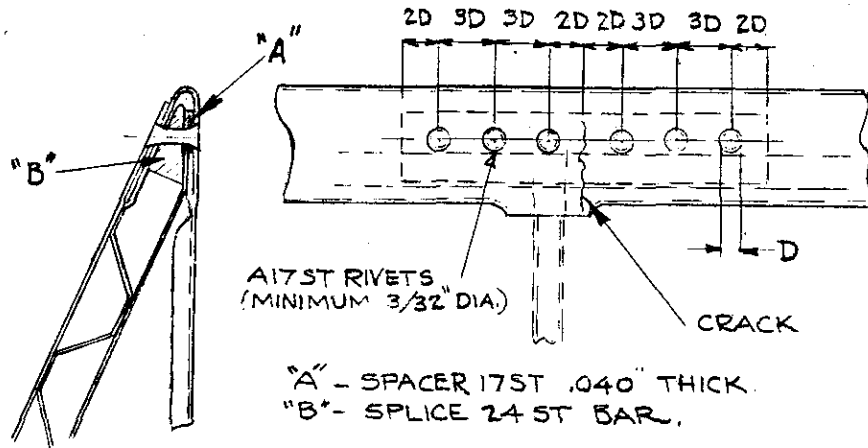
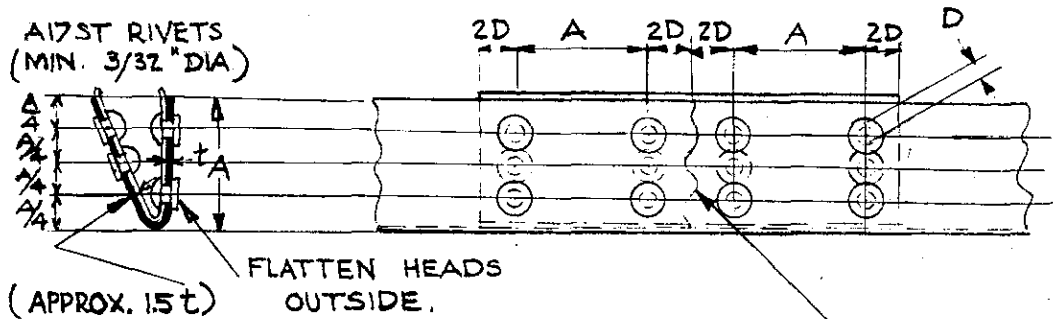

FIG. 11 - TYPICAL WING COMPRESSION RIB REPAIRS
Reference - Section 18.6017



1. STRAIGHTEN CRIMPED OVER PORTION.
2. INSERT HARDWOOD (ASH) INSERT SHAPED TO CONFORM TO T.E. PIECE.



1. STRAIGHTEN CRIMPED PORTION.
2. USE SAME AL. ALLOY AS IN ORIGINAL.

FIG.12 - TYPICAL REPAIRS OF TRAILING EDGES.

Reference - Section 18.6018

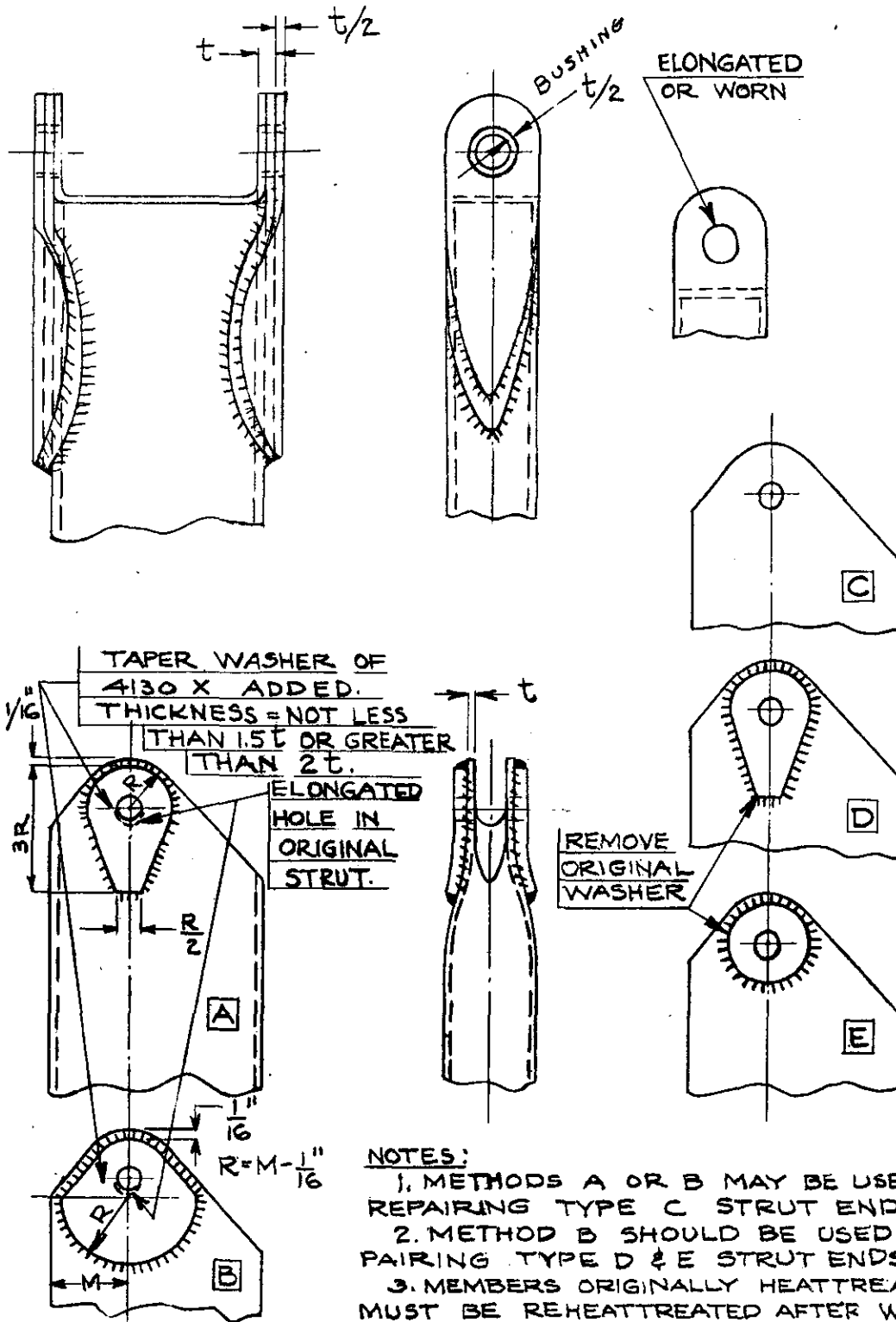
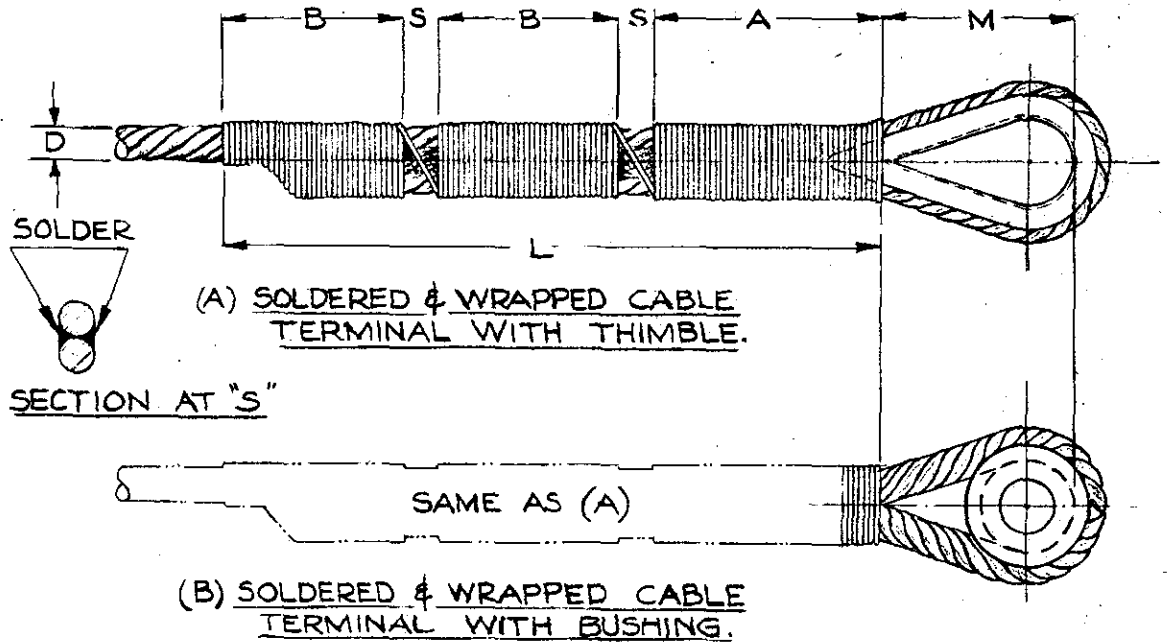

FIG.13 - TYPICAL METHODS OF REPAIRING ELONGATED OR WORN BOLT HOLES
Reference - Section 18.6042



D	L	A	B	M	S	WRAPPING * WIRE #48-19		SPECIFICATION NO.	
						DIA. INCH.	APPROX. LENGTH	THIMBLE (A)	BUSHING (B)
		PLUS OR MINUS 1/32 INCH							
3/32	2-1/4	3/4	5/8	3/4	1/8	.020	37"	AN-100-3	AN-III-3
1/8	2-3/4	1	3/4	3/4	1/8	.025	58"	AN-100-4	AN-III-4
5/32	3-3/8	1-1/8	1	7/8	1/8	.025	82"	AN-100-5	AN-III-5
3/16	3-5/8	1-1/4	1	1-1/8	3/16	.035	109	AN-100-6	AN-III-6
7/32	4	1-3/8	1-1/8	1-1/4	3/16	.035	—	AN-100-7	AN-III-7
1/4	4-1/2	1-1/2	1-1/4	1-1/2	1/4	.035	159	AN-100-8	AN-III-8
5/16	5-1/4	1-3/4	1-1/2	1-7/8	1/4	.050	195	AN-100-10	AN-III-10
3/8	6-1/4	2-1/4	1-3/4	2-1/8	1/4	.050	—	AN-100-12	AN-III-12
7/16	7	2-1/2	2	2-1/2	1/4	.050	—	AN-100-14	—
1/2	8	2-3/4	2-1/4	2-7/8	3/8	.050	—	AN-100-16	—

* ARMY SPECIFICATION - AN-QQ-W-435

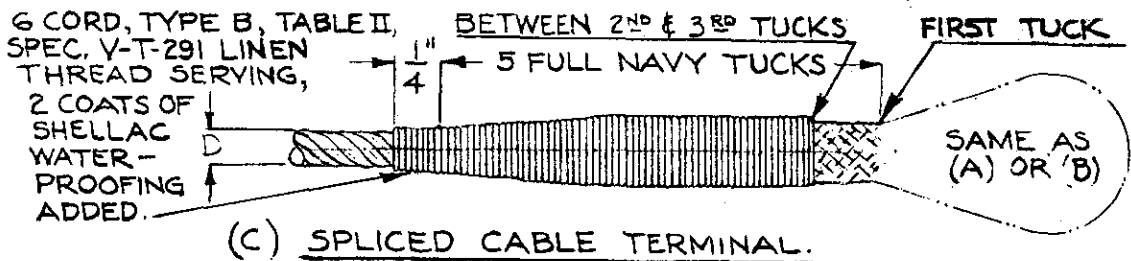
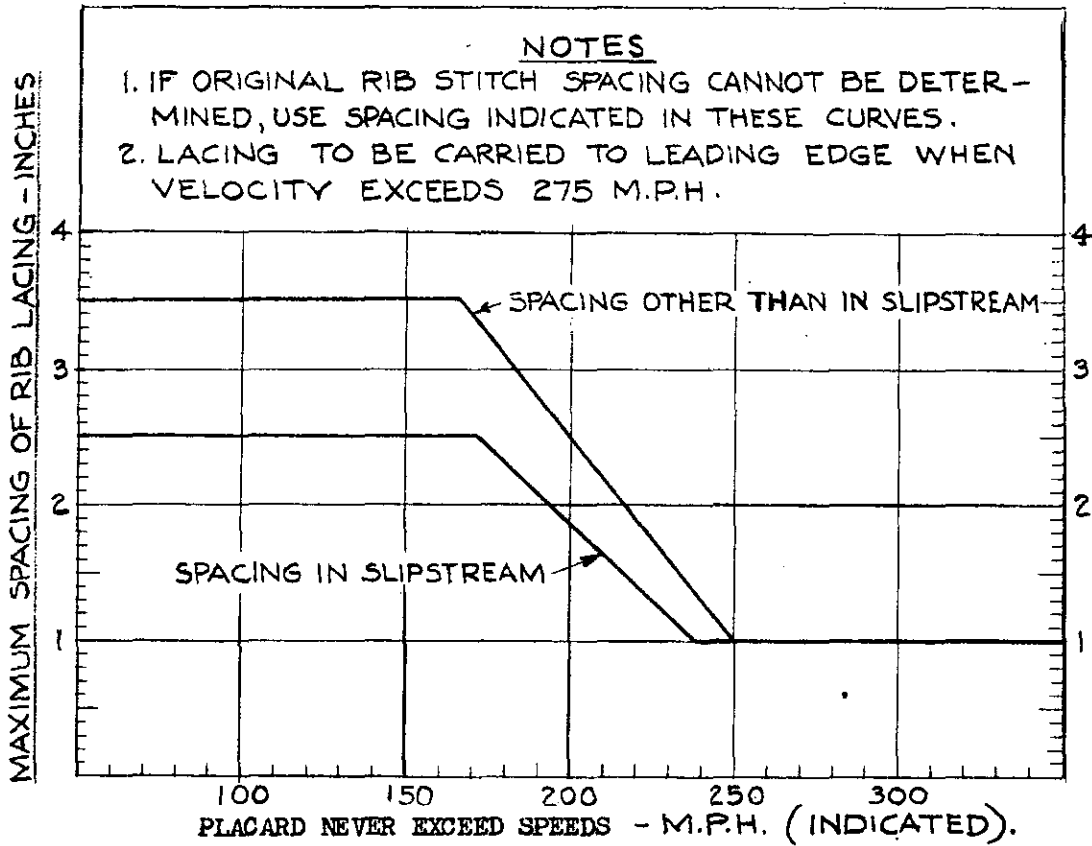
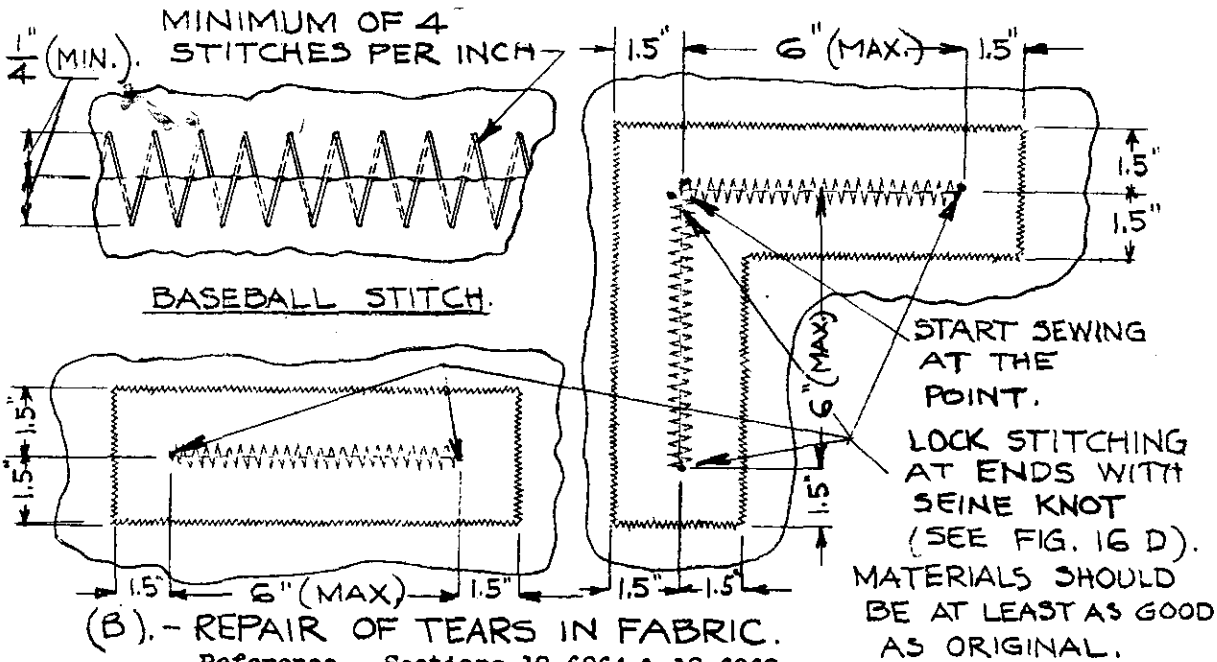

FIG. 14 - WRAPPED OR SPLICED CABLE TERMINALS.
 (SEE APPENDIX III FOR DETAILS OF SPLICING OPERATIONS)
 Reference -- Section 18.6052



CURVES PRESUME LEADING EDGE SUPPORT REINFORCEMENT SUCH AS PLYWOOD, METAL.

(A). - FABRIC ATTACHMENT (SPACING).



(B). - REPAIR OF TEARS IN FABRIC.

Reference - Sections 18.6064 & 18.6068

FIG. 15 - FABRIC ATTACHMENT (SPACING), REPAIR OF TEARS IN FABRIC.

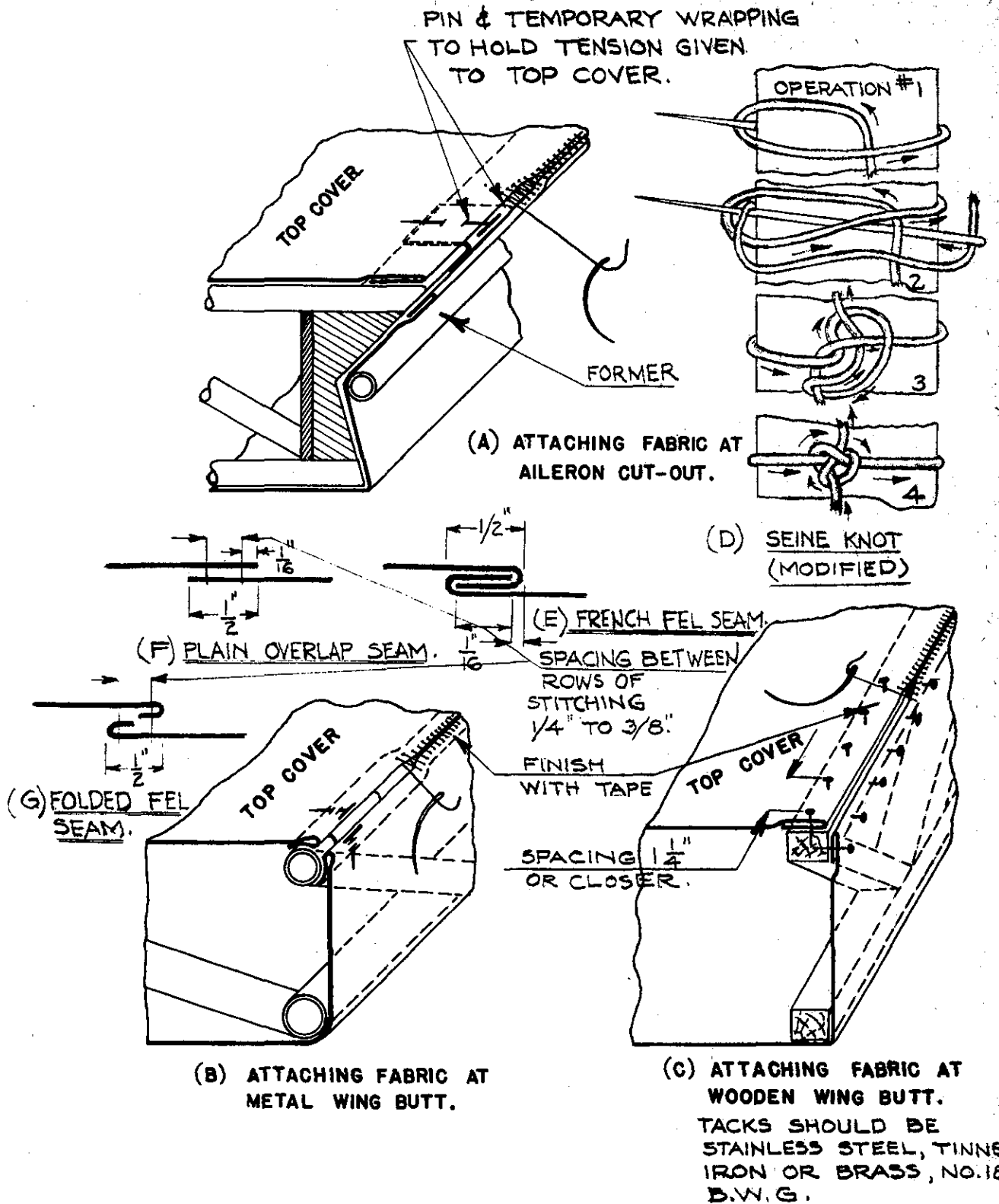
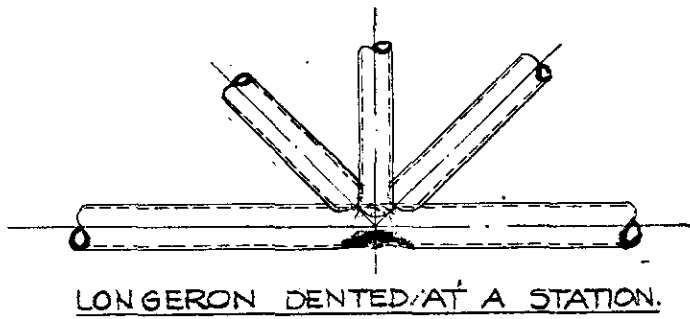
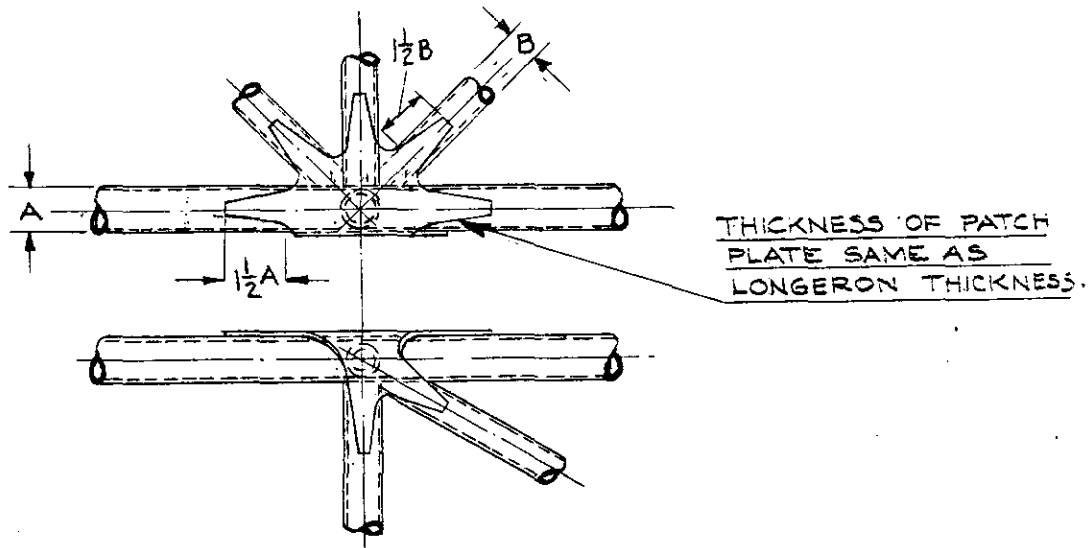

FIG. 16 - TYPICAL METHODS OF ATTACHING FABRIC .

Reference - Section 18.606



LONGERON DENTED AT A STATION.



PATCH PLATE BEFORE FORMING AND WELDING.

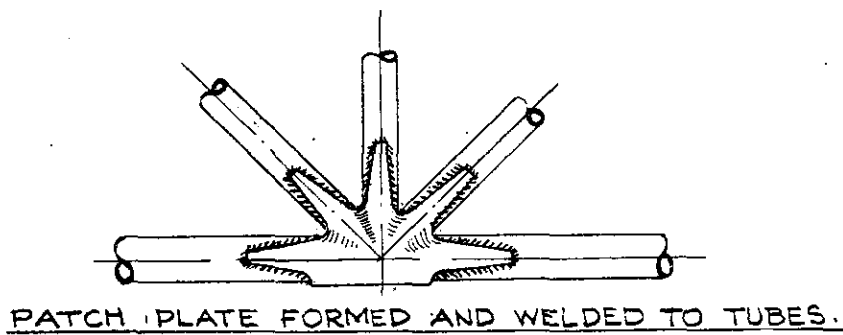

PATCH PLATE FORMED AND WELDED TO TUBES.

FIG. 17 - REPAIR OF A LONGERON DAMAGED AT A STATION USING A PATCH PLATE.
Reference - Section 18.6110

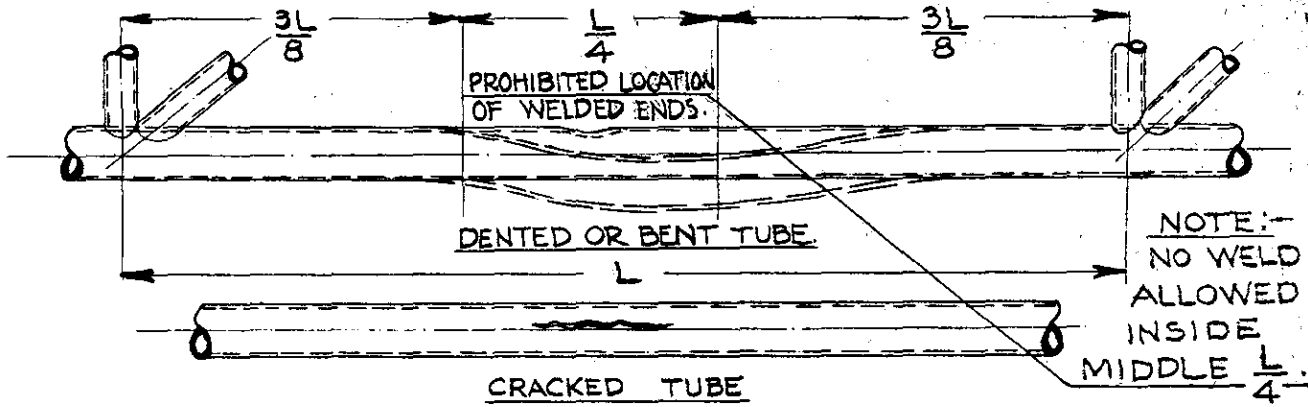

NOTE: -
 LOCALLY DENTED OR
 BENT MEMBERS SHOULD
 FIRST BE REFORMED
 IN CLAMP.



REINFORCEMENT SLEEVE TO BE AT LEAST OF SAME
 MATERIAL AND GAUGE AS TUBE BEING REPAIRED (A).

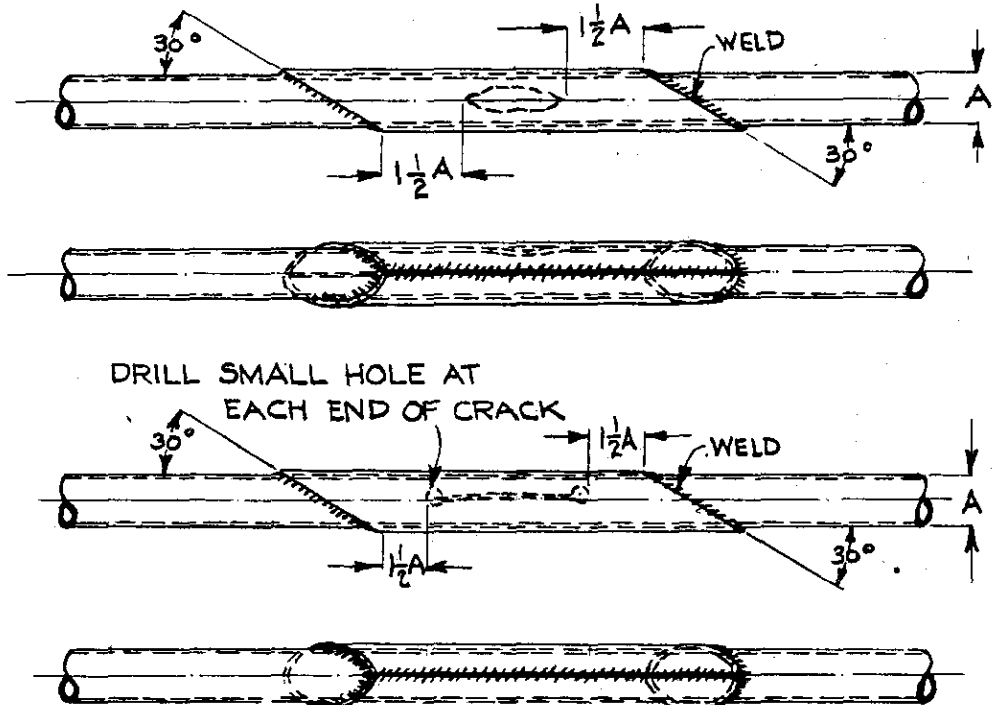

FIG. 18 - DENTED, BENT OR CRACKED TUBE REPAIR IN A BA

Reference - Section 18.6111

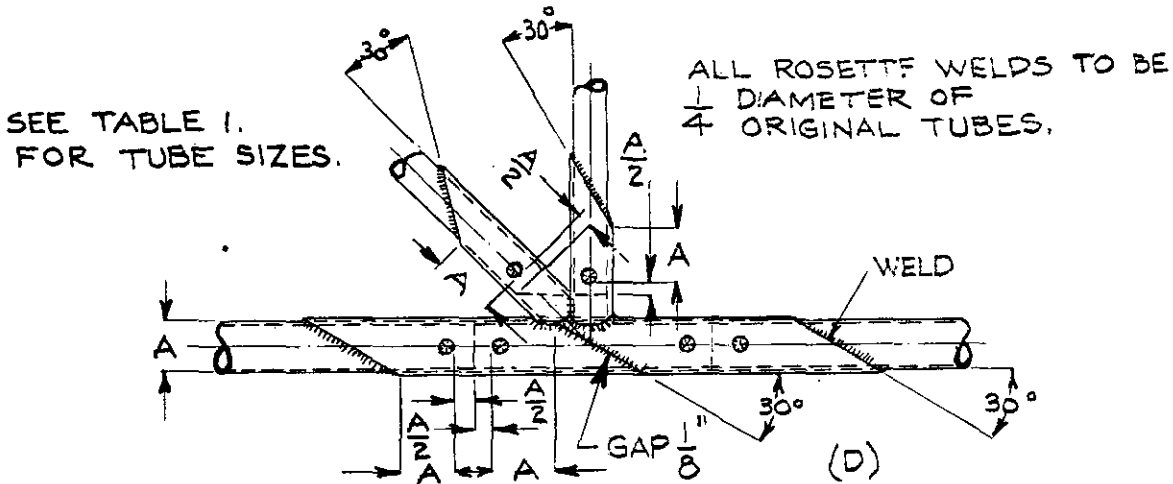
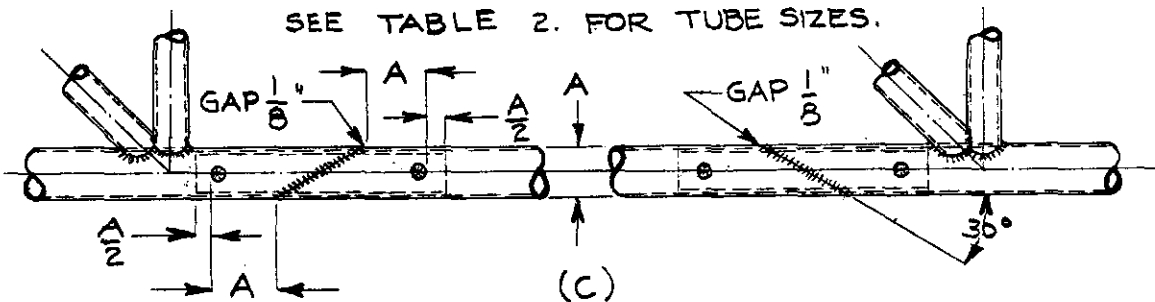
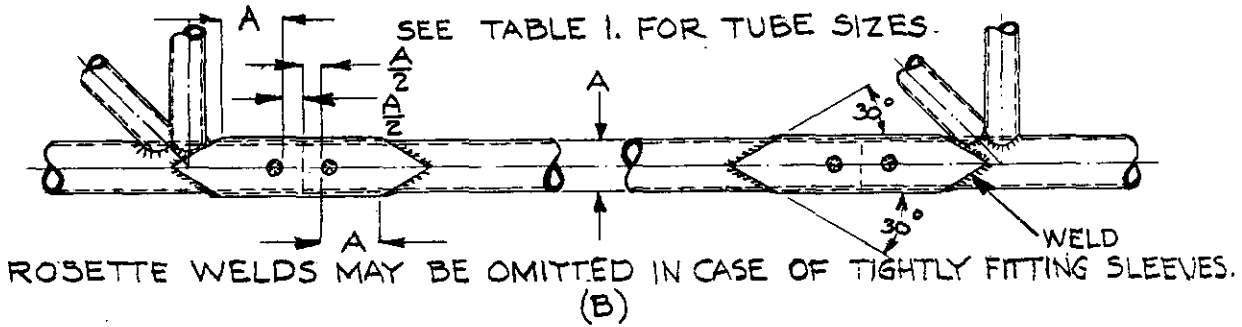
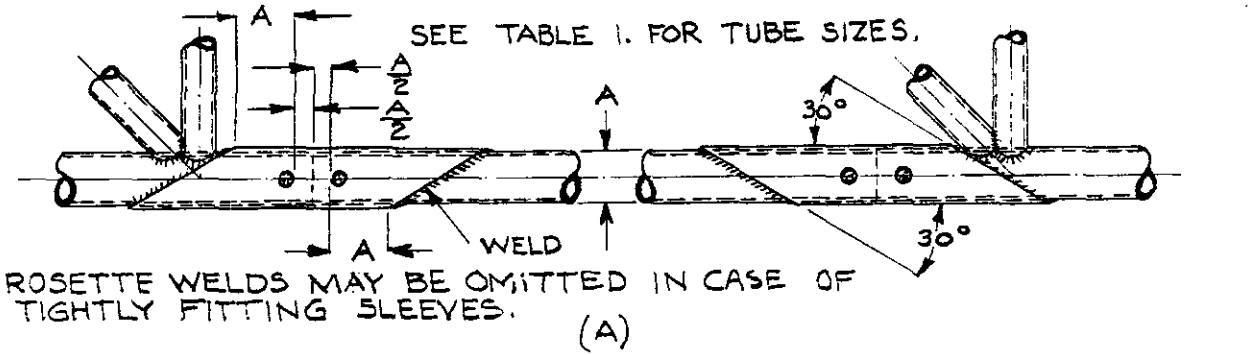
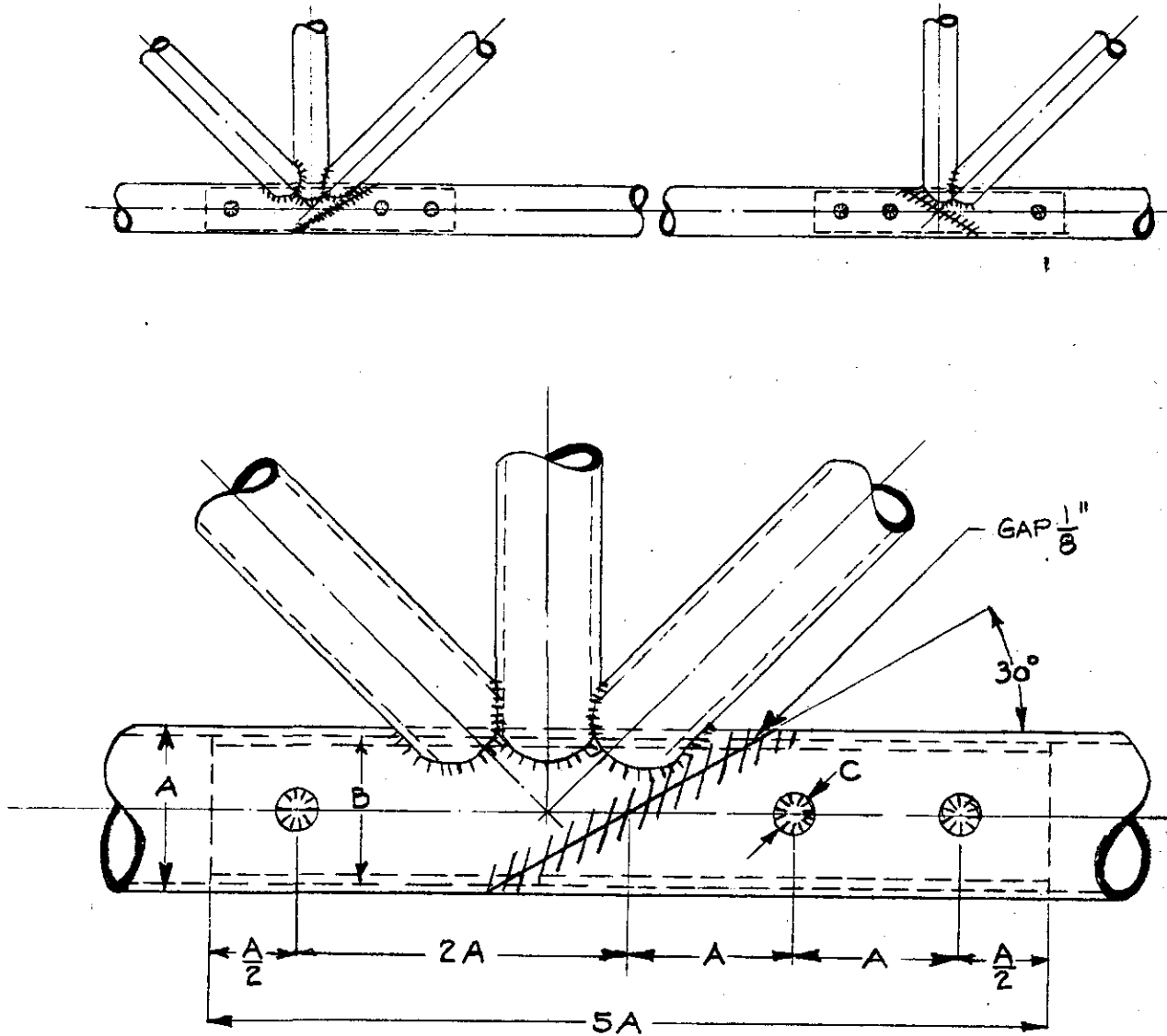

FIG. 19 - ALTERNATE TUBE REPAIR METHODS.

Reference - Section 18.6112, 18.614



A- ORIGINAL TUBE.
 B- INSERT TUBE.
 C- $\frac{1}{4}$ DIAMETER OF TUBE A (6 ROSETTE WELDS FOR EACH SPLICE, DRILL OUTSIDE TUBE ONLY).
 FOR DIMENSION OF INSERT TUBE B SEE FIG. 2.

FIG. 20 - TYPICAL LONGERON SPLICE USING SAME DIAMETER REPLACEMENT TUBE.

Reference - Section 18.6113, 18.614

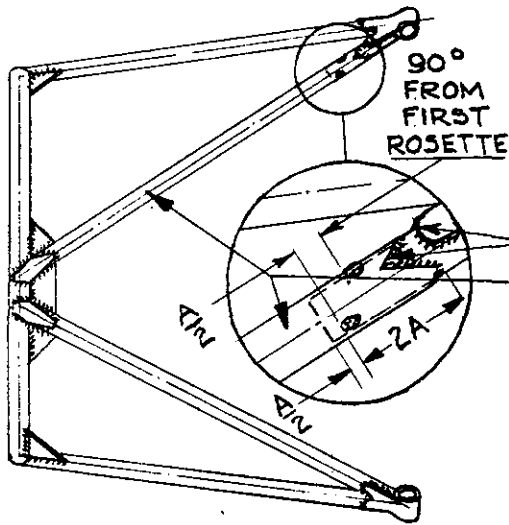
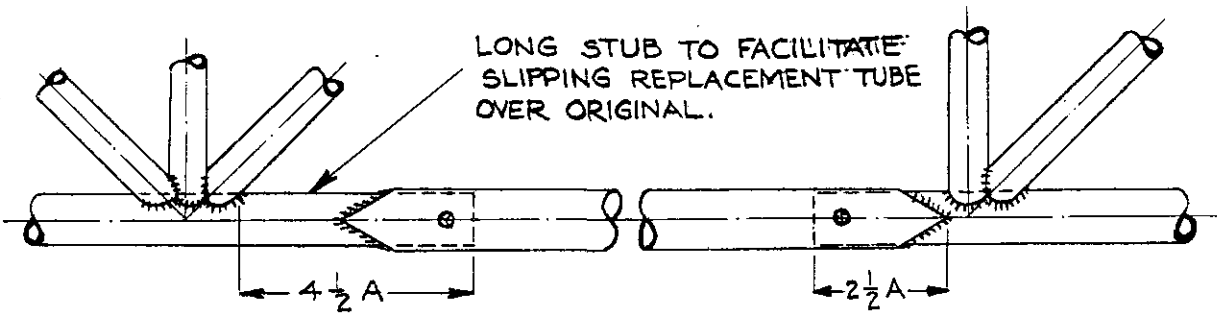

A - ORIGINAL TUBE DIAMETER
 B - REPLACEMENT TUBE DIAMETER
 C - ROSETTE DIAMETER = $\frac{1}{4}$ DIAMETER OF TUBE A. (DRILL OUTSIDE TUBE ONLY).

STRADDLE FINGER PLATE WITH "V" CUT. NEW TUBE.

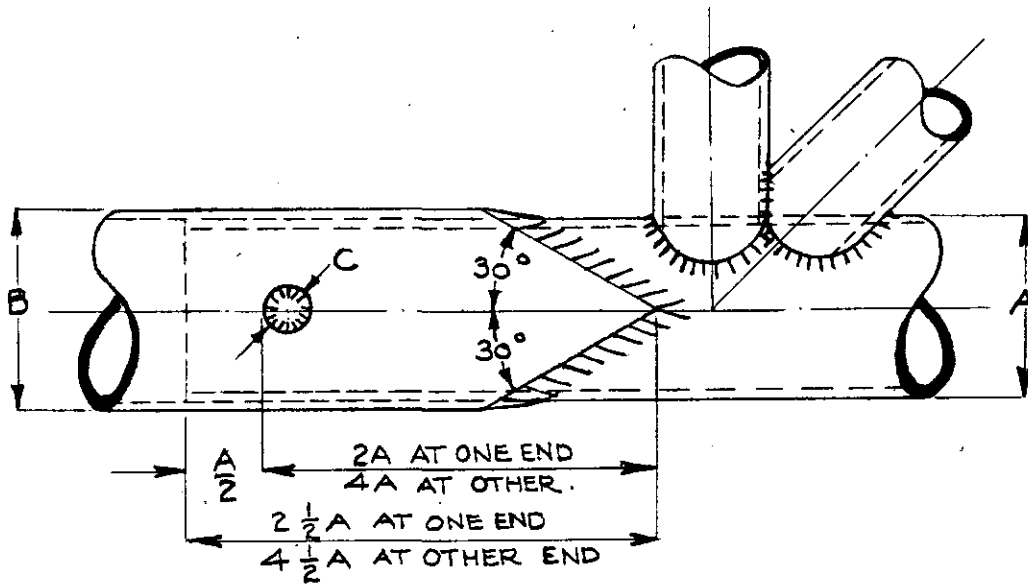

FIG. 21 - ENGINE MOUNT AND LONGERON REPAIR USING LARGER DIAMETER REPLACEMENT TUBE.

Reference - Sections 18.6113, 18.613, 18.614

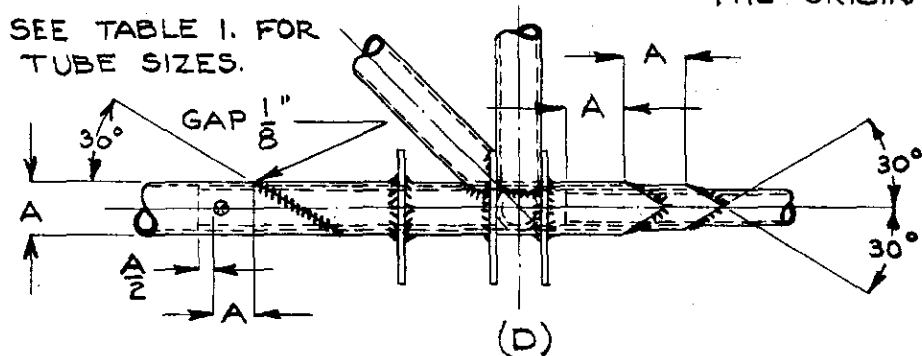
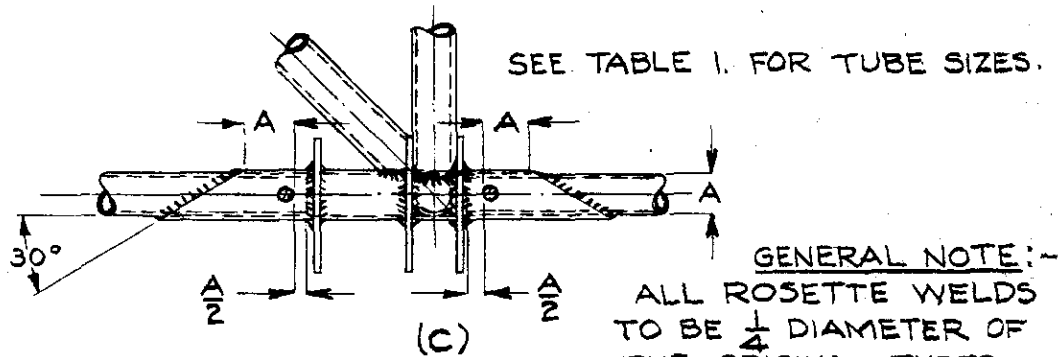
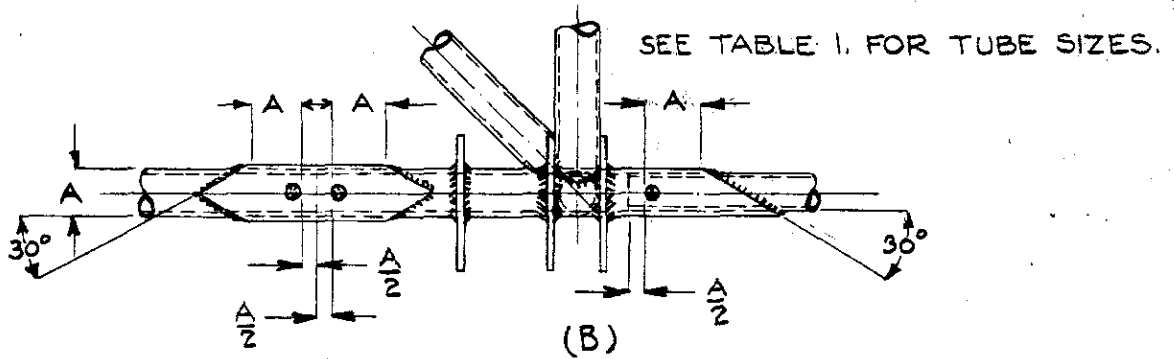
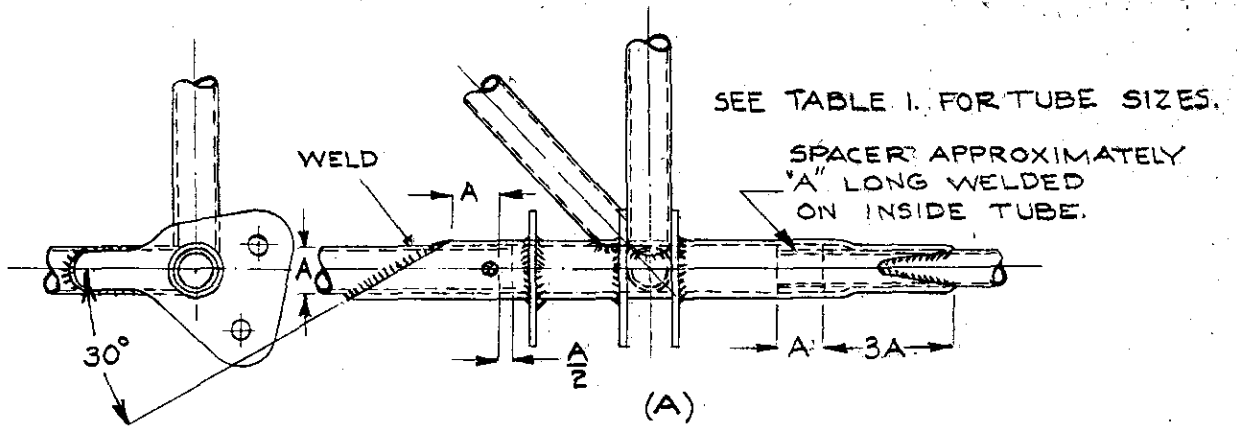
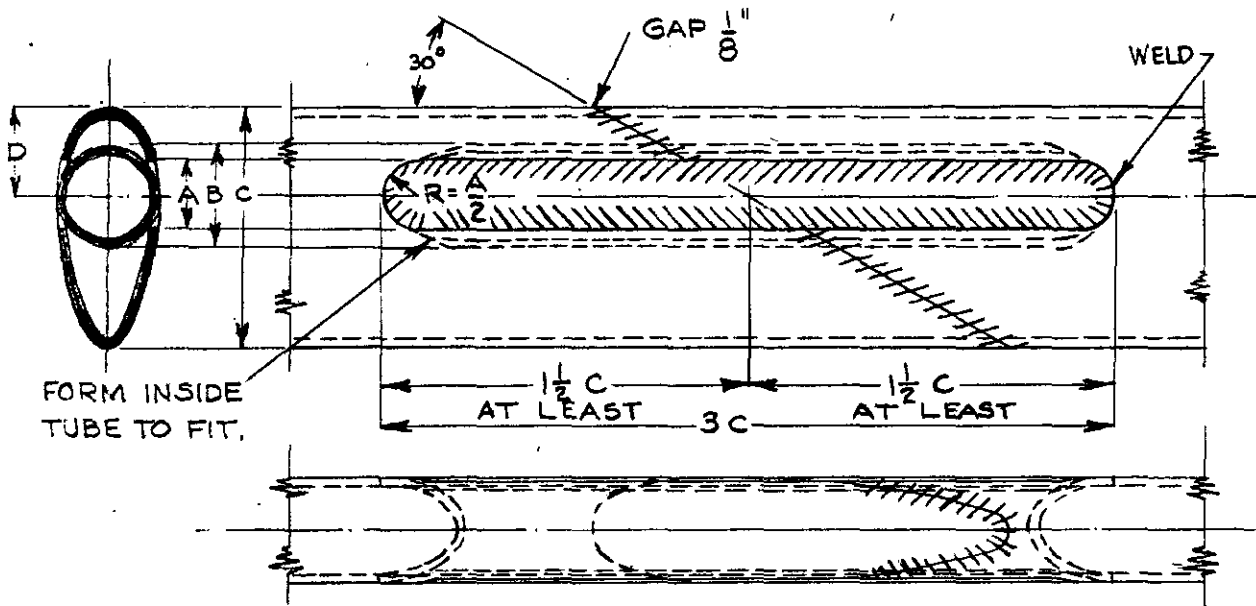

FIG. 22 - ALTERNATE TYPICAL REPAIRS AT A FITTING.

Reference - Section 18.612



- A - SLOT WIDTH (ORIGINAL TUBE)
 B - OUTSIDE DIAMETER (INSERT TUBE)
 C - STREAMLINE TUBE LENGTH OF MAJOR AXIS.

S.L. SIZE	A	B	C	D
1"	3/8"	9/16"	1.340"	.496"
1 1/4	3/8	11/16	1.670	.619
1 1/2	1/2	7/8	2.005	.743
1 3/4	1/2	1	2.339	.867
2	1/2	1 1/8	2.670	.991
2 1/4	1/2	1 1/4	3.008	1.115
2 1/2	1/2	1 3/8	3.342	1.239

ROUND INSERT TUBE (B) SHOULD BE AT LEAST OF SAME MATERIAL AND ONE GAUGE THICKER THAN ORIGINAL STREAMLINE TUBE (C).

FIG. 23 - STREAMLINE TUBE SPLICE USING ROUND TUBE.
 (APPLICABLE TO LANDING GEARS).

Reference - Section 18.6141

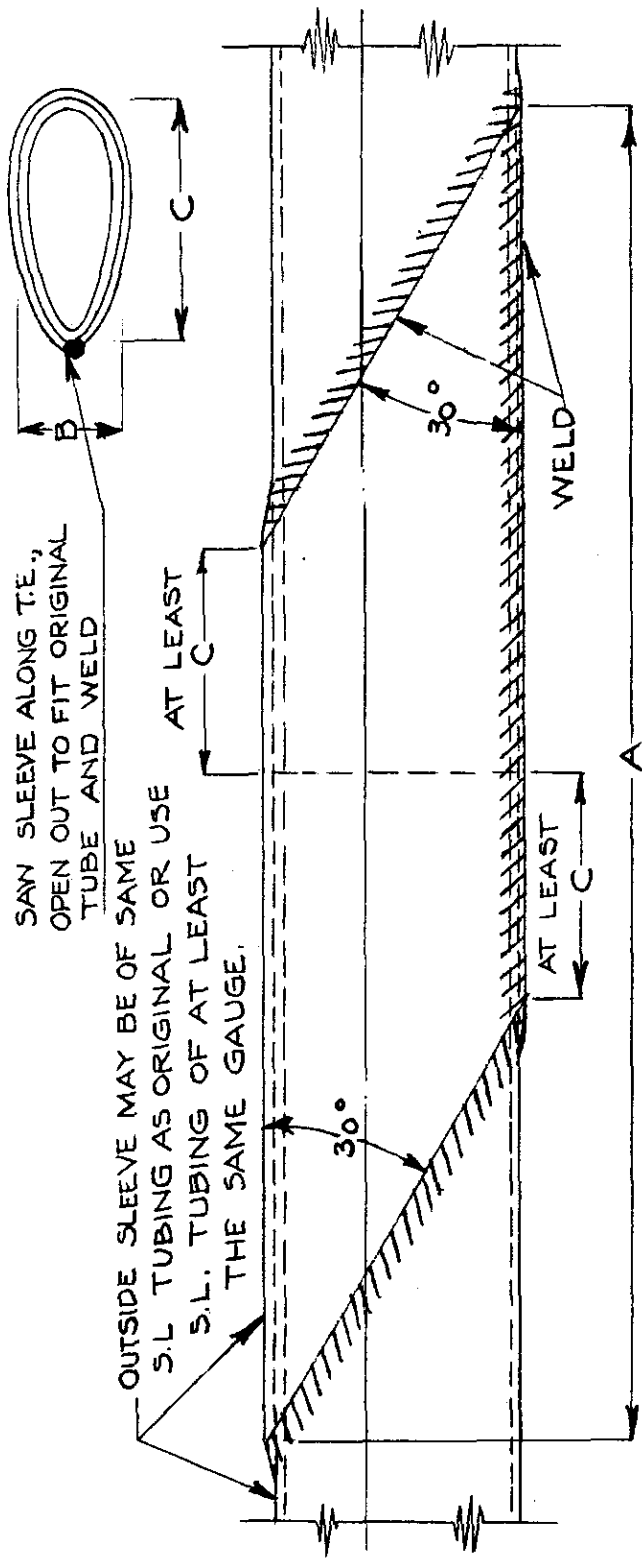

A - MINIMUM LENGTH OF SLEEVE
B - STREAMLINE TUBE LENGTH OF MINOR AXIS
C - " " " MAJOR "

S.L. SIZE	A	B	C
1"	7.324	.572	1.340
1 1/4	9.128	.714	1.670
1 1/2	10.960	.858	2.005
1 3/4	12.784	1.000	2.339
2	14.594	1.144	2.670
2 1/4	16.442	1.286	3.008
2 1/2	18.268	1.430	3.342

FIG 24 - STREAMLINE TUBE SPLICE USING SPLIT SLEEVE.
(APPLICABLE TO WING & TAIL SURFACE BRACE
STRUTS & OTHER MEMBERS)

Reference - Sections
18.6141, 18.6160

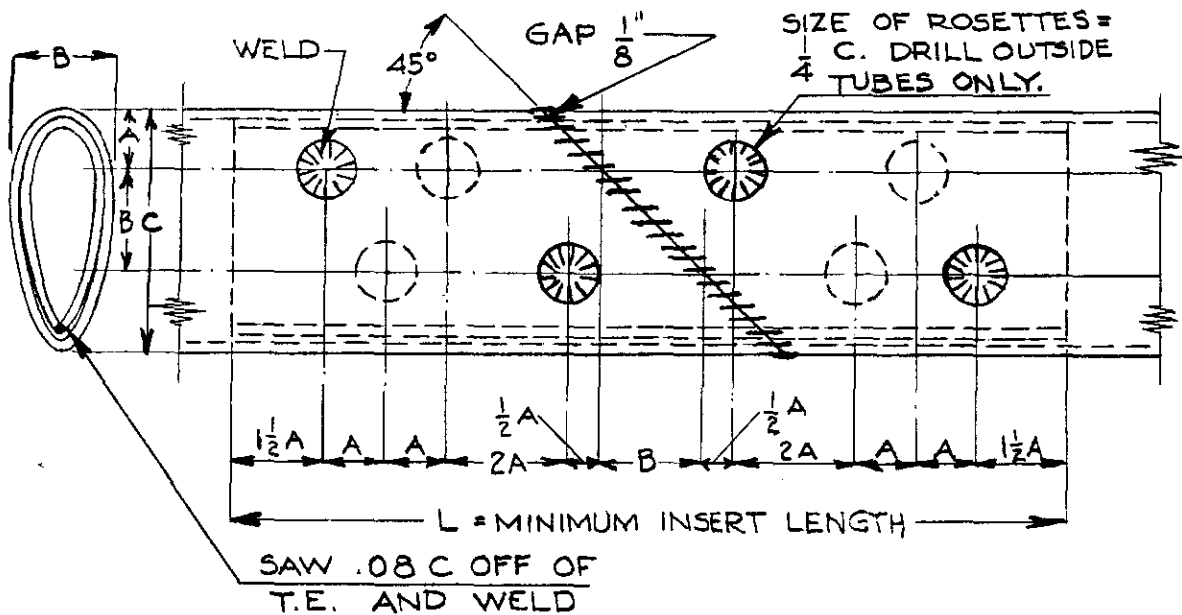

INSERT TUBE IS OF SAME STREAMLINE TUBING AS ORIGINAL.

A IS $\frac{2}{3}$ B.

B IS MINOR AXIS LENGTH OF ORIGINAL STREAMLINE TUBE

C " MAJOR " " " " " " " "

S.L. SIZE	A	B	C	L
1"	.382	.572	1.340	5.16
1 $\frac{1}{4}$.476	.714	1.670	6.43
1 $\frac{1}{2}$.572	.858	2.005	7.72
1 $\frac{3}{4}$.667	1.000	2.339	9.00
2	.763	1.144	2.670	10.30
2 $\frac{1}{4}$.858	1.286	3.008	11.58
2 $\frac{1}{2}$.954	1.430	3.342	12.88

FIG. 25 - STREAMLINE TUBE SPLICE USING SPLIT INSERT. (APPLICABLE TO LANDING GEARS)

Reference - Section 18.6141

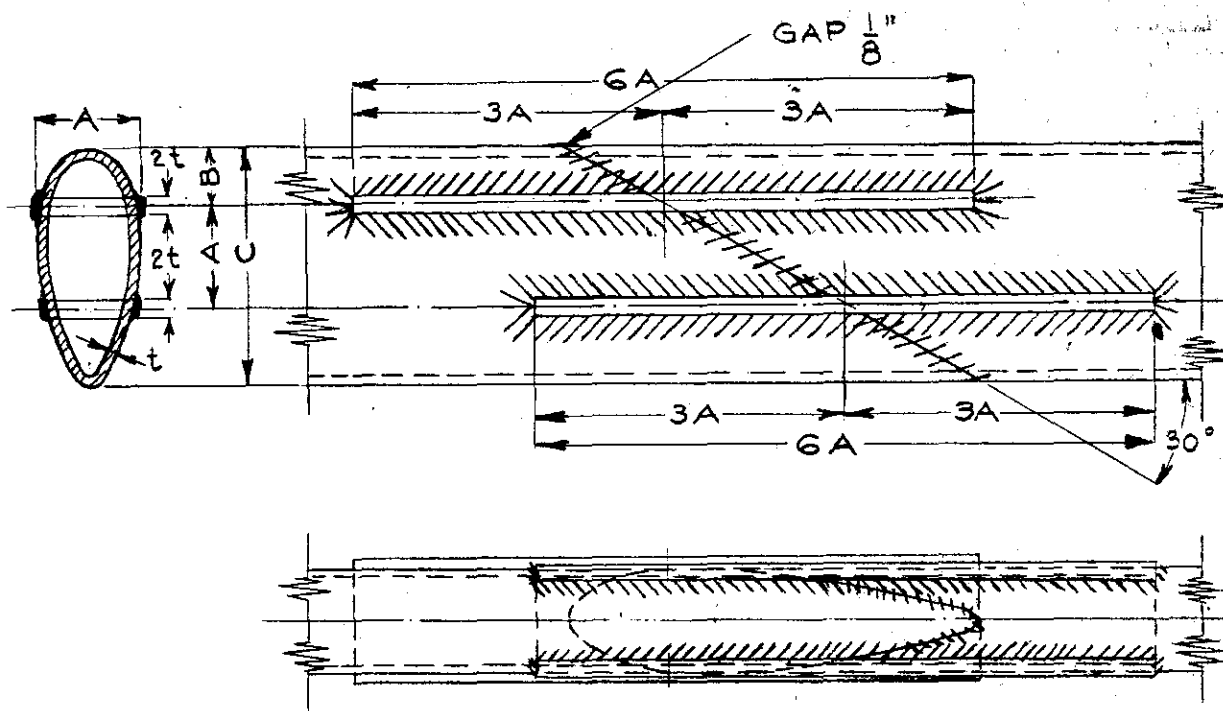

- A - STREAMLINE TUBE LENGTH OF MINOR AXIS, PLATE WIDTHS.
- B - DISTANCE OF FIRST PLATE FROM LEADING EDGE, $\frac{2}{3}A$.
- C - STREAMLINE TUBE LENGTH OF MAJOR AXIS.

S.L. SIZE	A	B	C	6A
1"	.572	.382	1.340	3.43
1 1/4	.714	.476	1.670	4.28
1 1/2	.858	.572	2.005	5.15
1 3/4	1.000	.667	2.339	6.00
2	1.144	.762	2.670	6.86
2 1/4	1.286	.858	3.008	7.72
2 1/2	1.430	.954	3.342	8.58

FIG. 26 - STREAMLINE TUBE SPLICE USING PLATES (APPLICABLE TO LANDING GEARS).

Reference - Section 18.6141

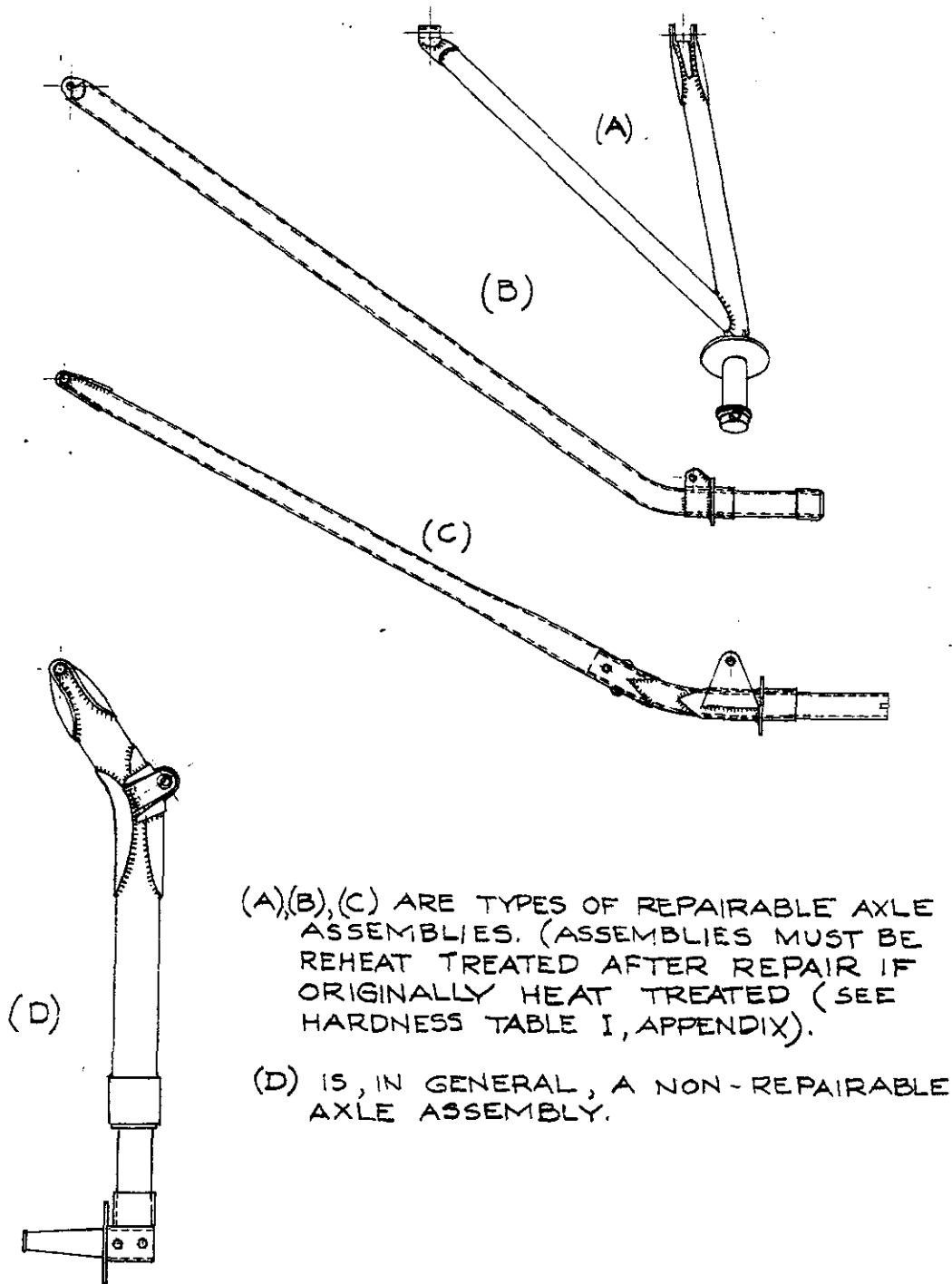

FIG.27 - REPRESENTATIVE TYPES OF REPAIRABLE AND NON-REPAIRABLE AXLE ASSEMBLIES.

Reference - Section 18.6142

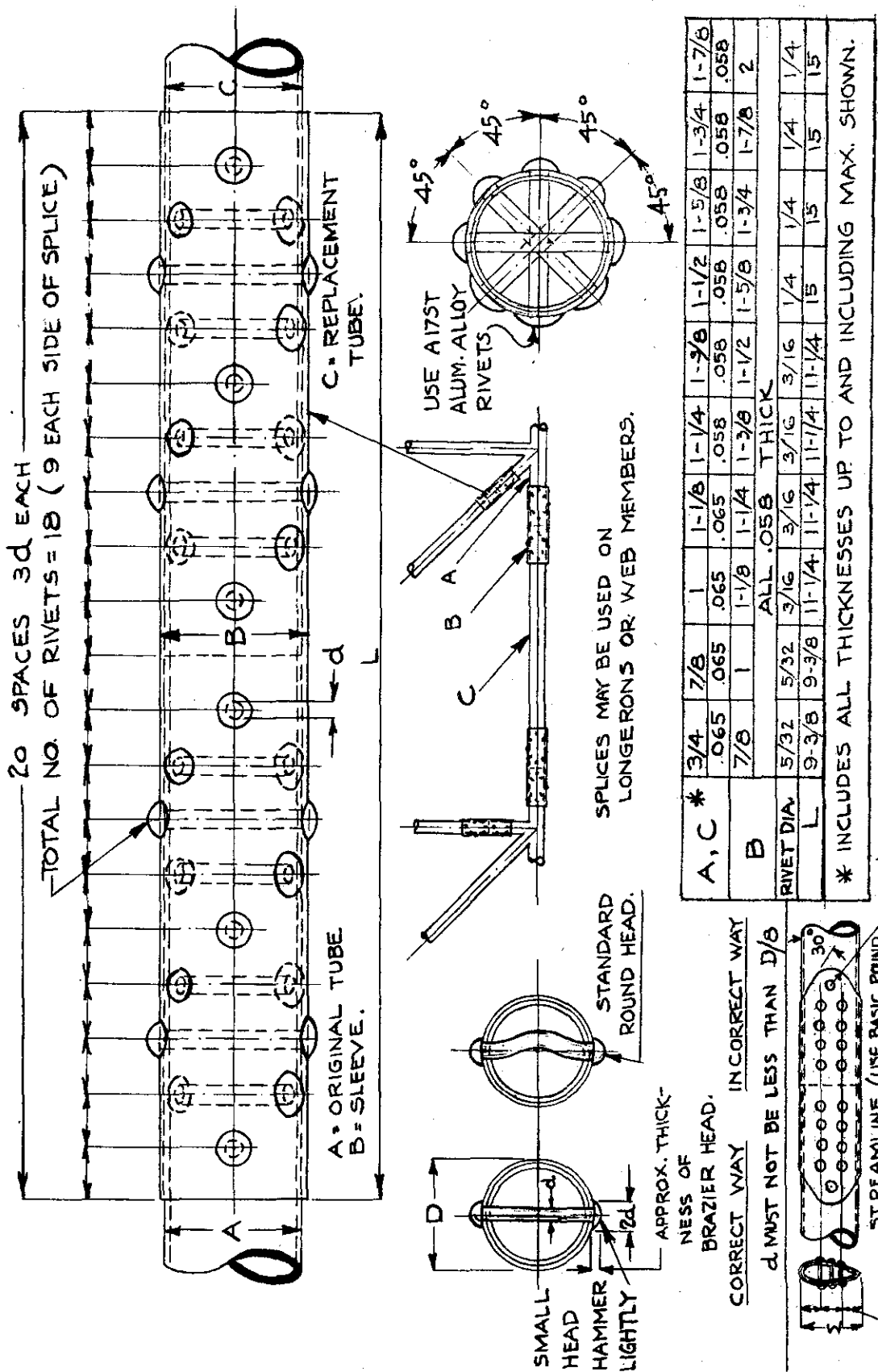
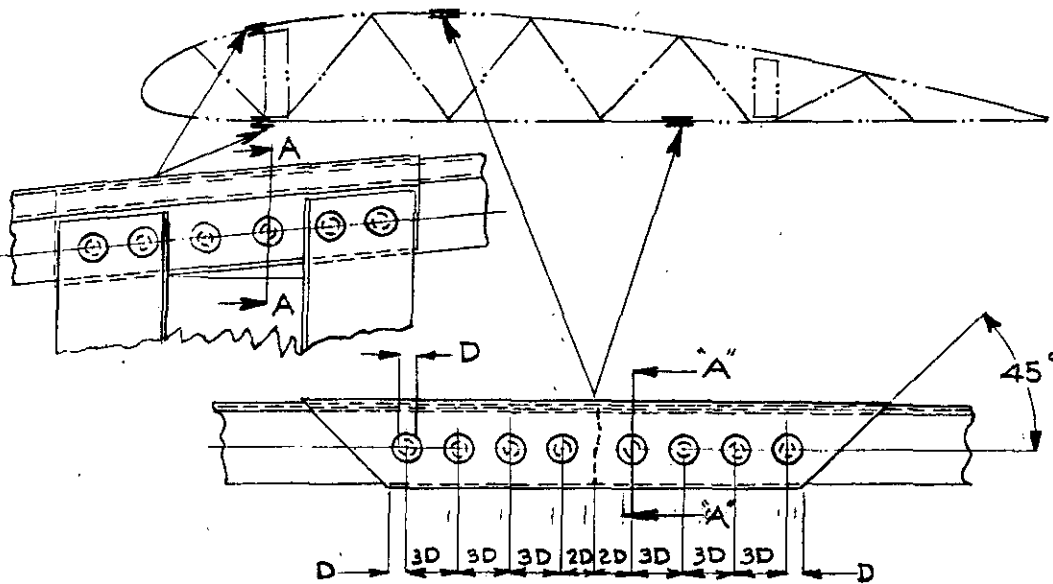
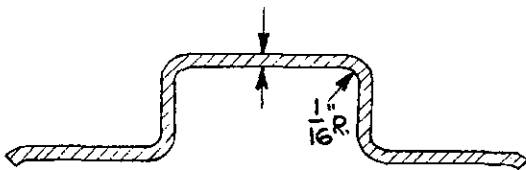

FIG. 28 - TYPICAL REPAIR METHOD FOR TUBULAR MEMBERS OF ALUMINUM ALLOY. Reference - Section 18.6440



AT LEAST AS THICK AS ORIGINAL



MATERIAL - DURAL OR AL. ALLOY USED IN ORIGINAL CONSTRUCTION.
SCALE - TWICE SIZE.

(AT LEAST)

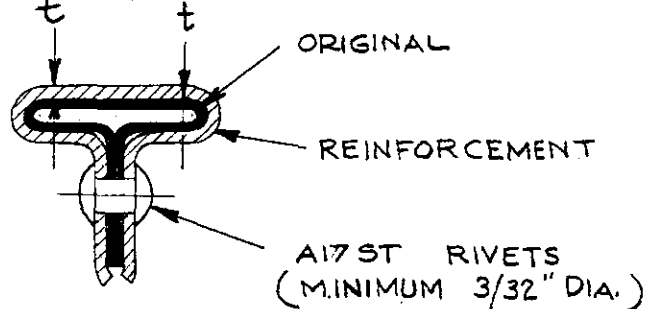

SECTION "A-A"
SCALE - TWICE SIZE

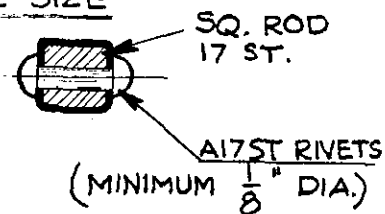
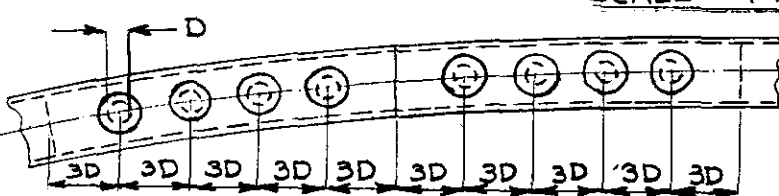

*NOTE: COMMONLY FOUND ON SMALL AND MEDIUM SIZE AIRCRAFT (SEE FIG. 30).

FIG. 29 TYPICAL REPAIR FOR BUCKLED OR CRACKED FORMED METAL WING RIB CAPSTRIPS.*

Reference - Section 18.6442

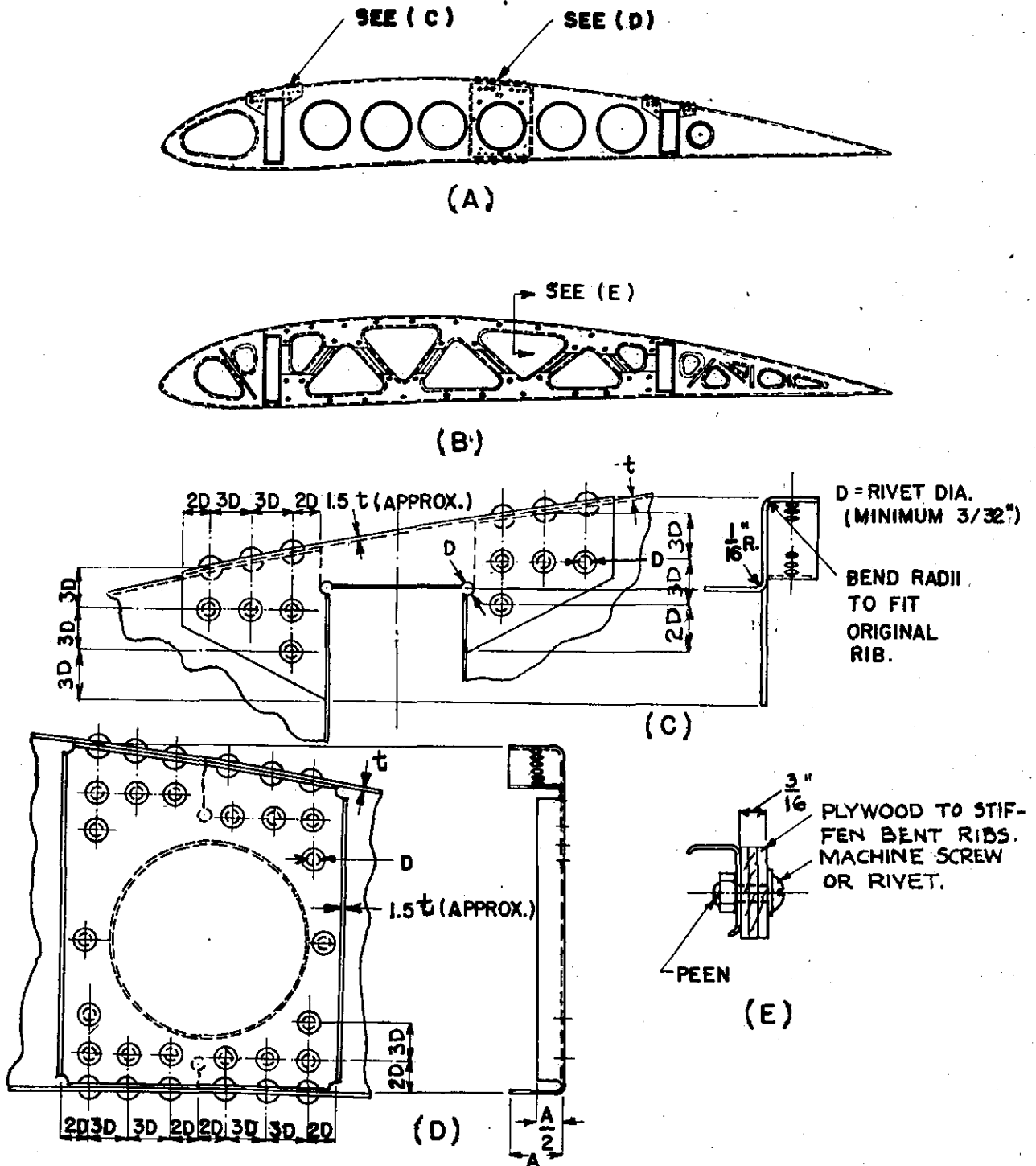
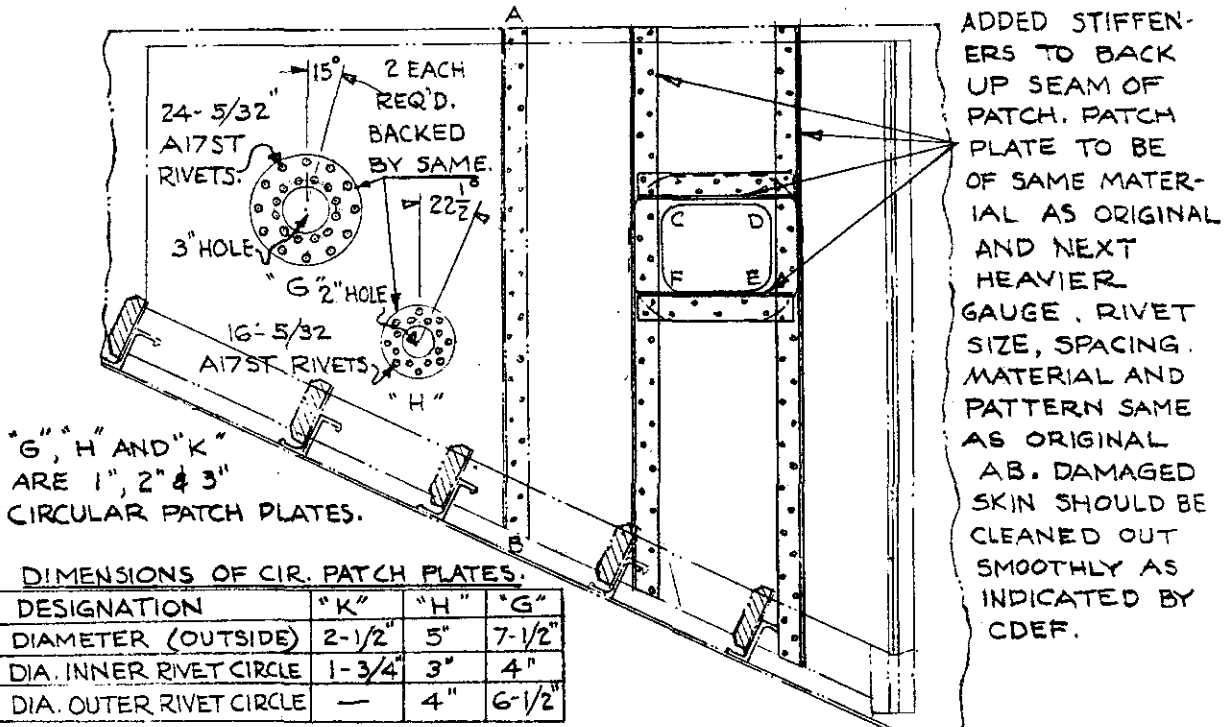

FIG. 30 - TYPICAL METAL RIB REPAIRS (COMMONLY FOUND ON SMALL AND MEDIUM SIZE AIRCRAFT.)
 Reference - Section 18.6442

(A).



"G", "H" AND "K" ARE 1", 2" & 3" CIRCULAR PATCH PLATES.

DIMENSIONS OF CIR. PATCH PLATES.

DESIGNATION	"K"	"H"	"G"
DIAMETER (OUTSIDE)	2-1/2"	5"	7-1/2"
DIA. INNER RIVET CIRCLE	1-3/4"	3"	4"
DIA. OUTER RIVET CIRCLE	—	4"	6-1/2"

ADDED STIFFENERS TO BACK UP SEAM OF PATCH. PATCH PLATE TO BE OF SAME MATERIAL AS ORIGINAL AND NEXT HEAVIER GAUGE. RIVET SIZE, SPACING, MATERIAL AND PATTERN SAME AS ORIGINAL AB. DAMAGED SKIN SHOULD BE CLEANED OUT SMOOTHLY AS INDICATED BY CDEF.

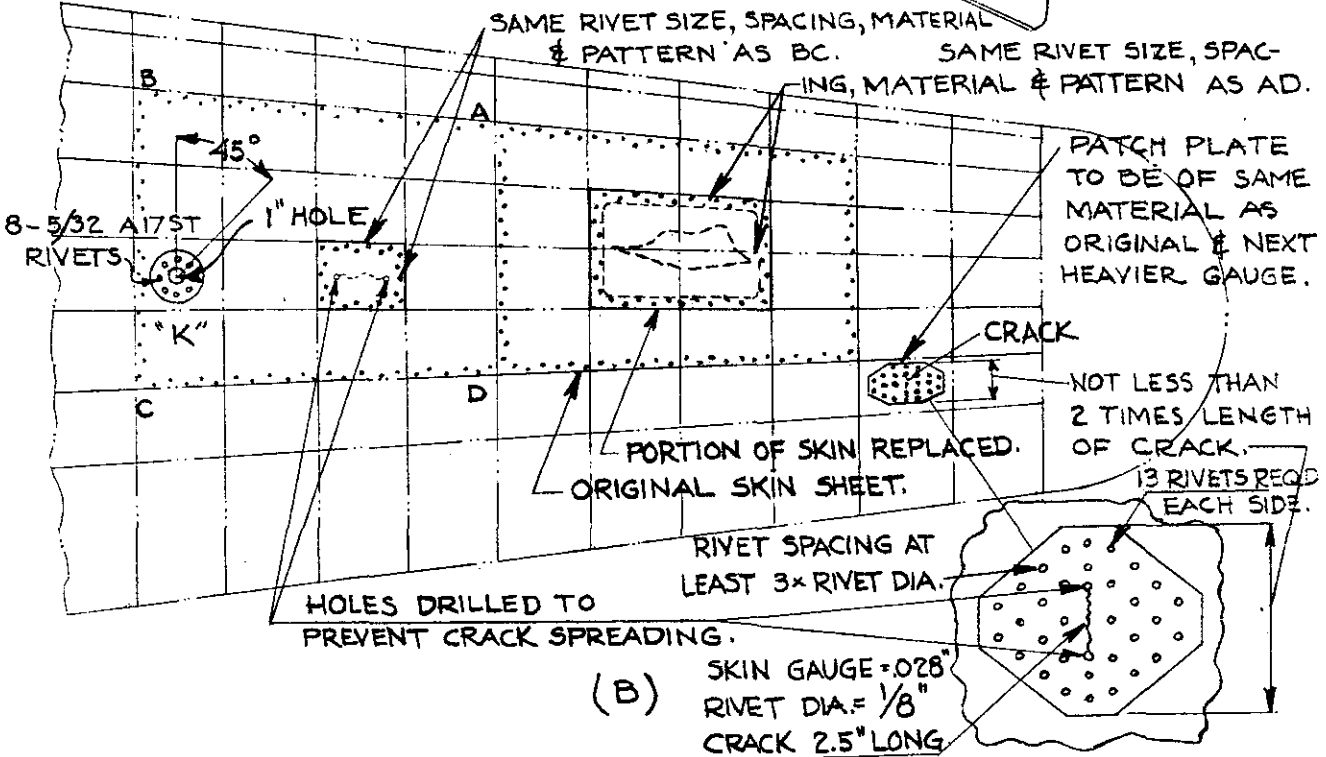

(B)

SKIN GAUGE = .028"
RIVET DIA. = 1/8"
CRACK 2.5" LONG

FIG. 31 - TYPICAL REPAIRS OF STRESSED SHEET COVERING.

Reference - Section 18.6443, 18.6444

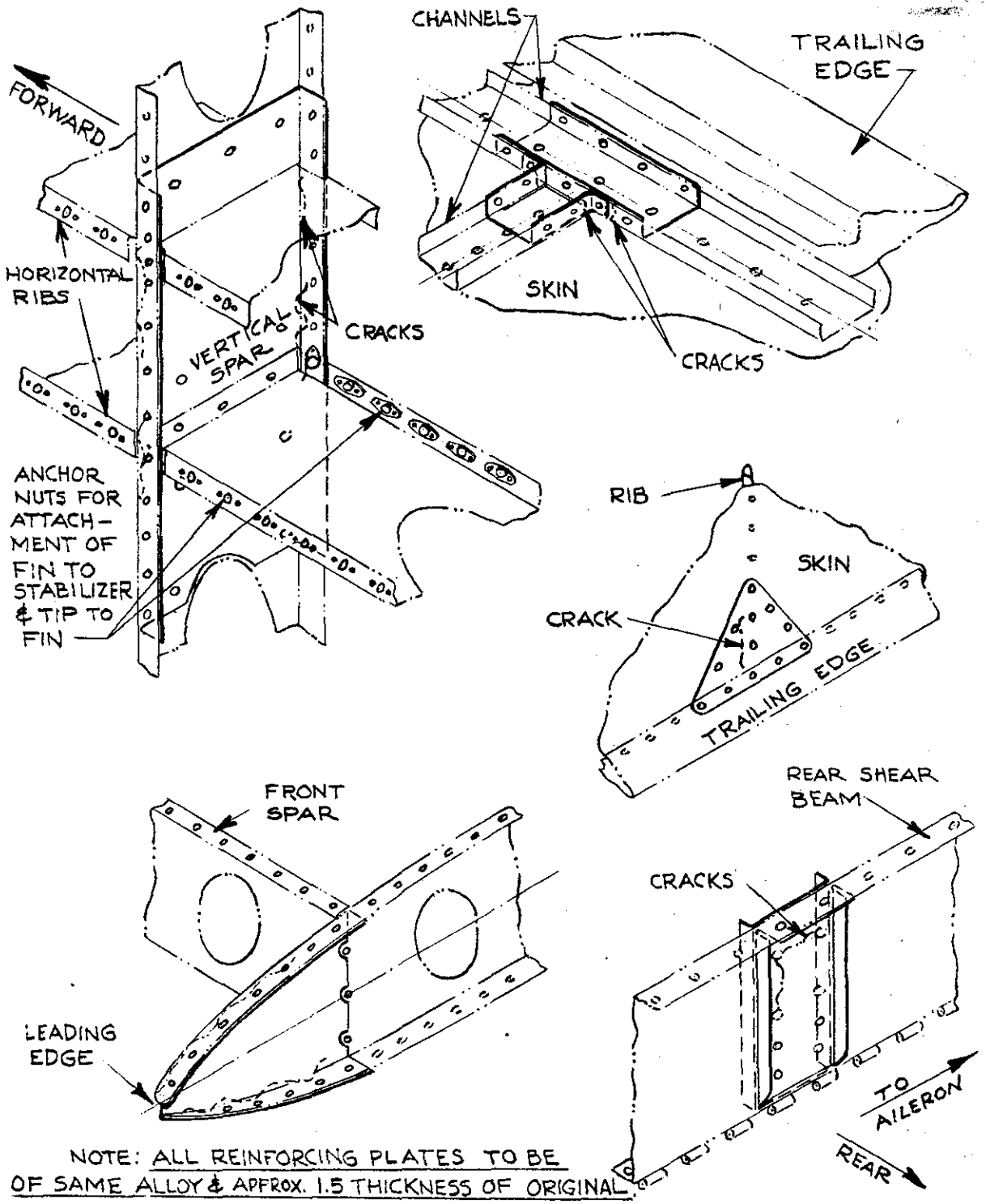
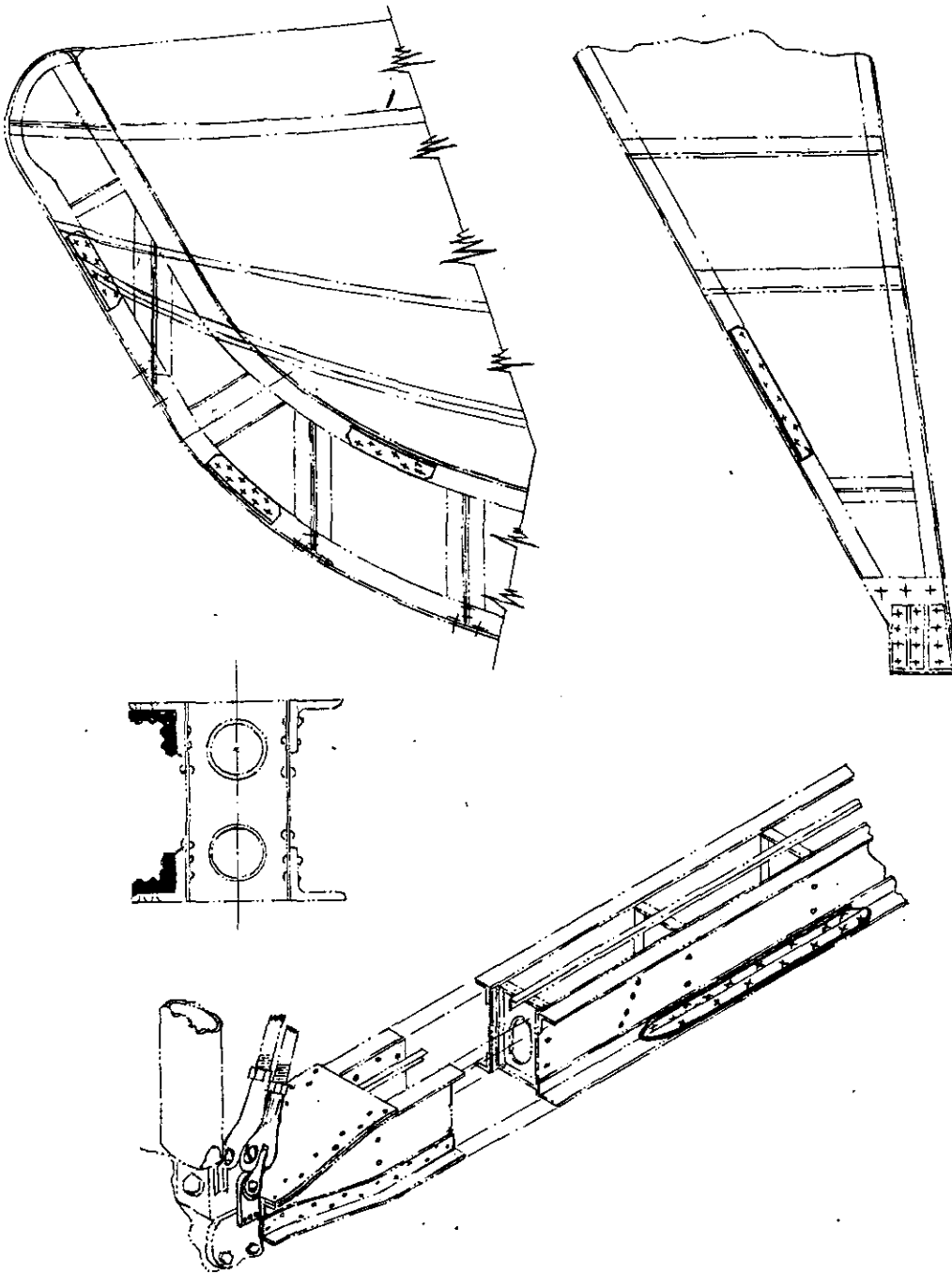

FIG. 32 - TYPICAL METHODS OF REPAIRING CRACKED LEADING & TRAILING EDGES & RIB INTERSECTIONS.

Reference - Section 18.6448



NOTE : STRENGTH INVESTIGATION USUALLY REQUIRED FOR THIS TYPE OF REPAIR.

FIG.33 — APPLICATION OF TYPICAL FLANGE SPLICES AND REINFORCEMENT.

Reference - Section 18.6447

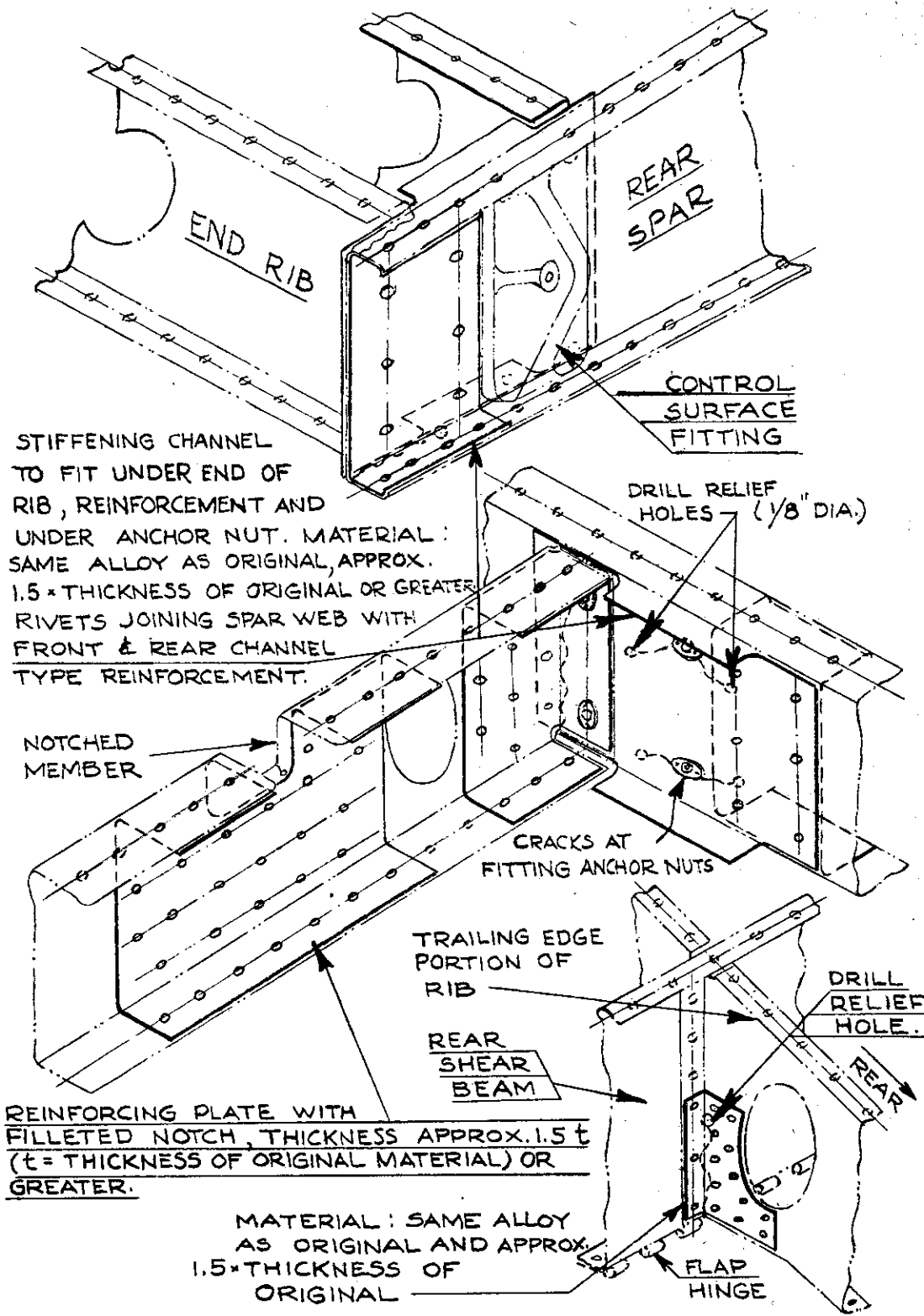

FIG. 34 - TYPICAL METHODS OF REPAIRING CRACKED MEMBERS AT FITTINGS. Reference - Section 18.6448

CRACKS IN WING SKIN & TRANS. STIFFENER AT DRAG RIB JUNCTION. REPAIR BY OUTSIDE GUSSETS.

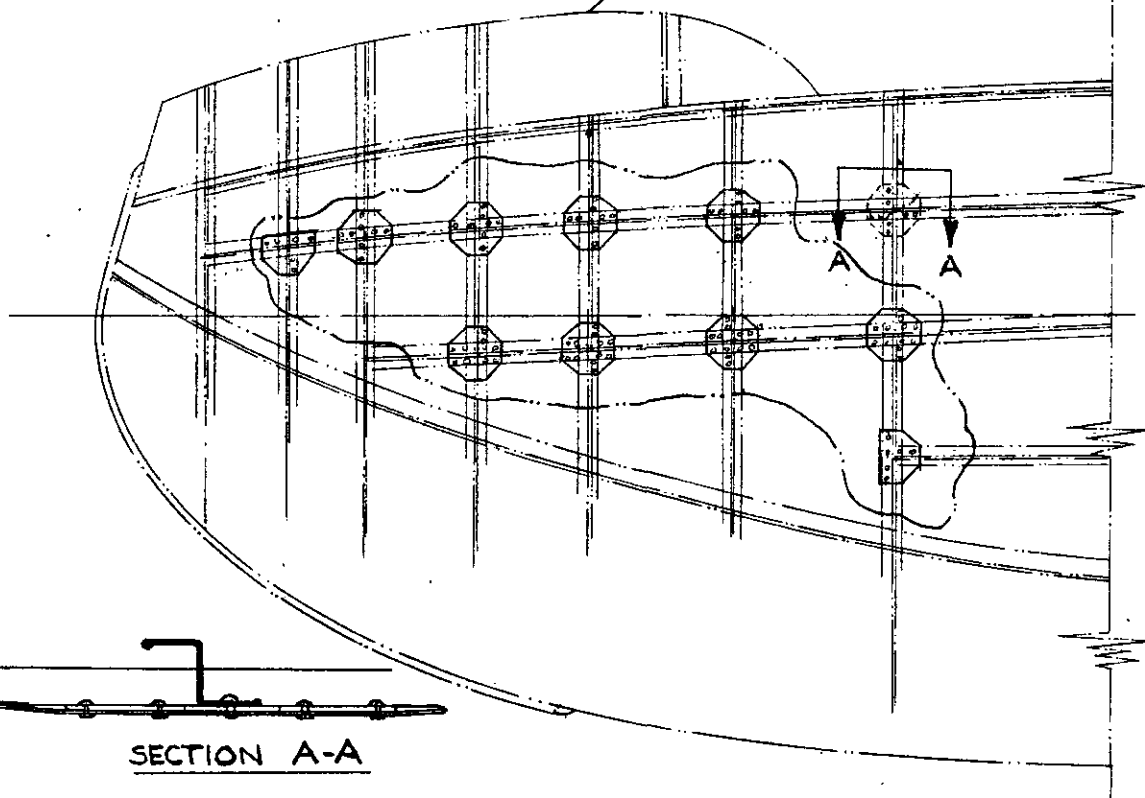
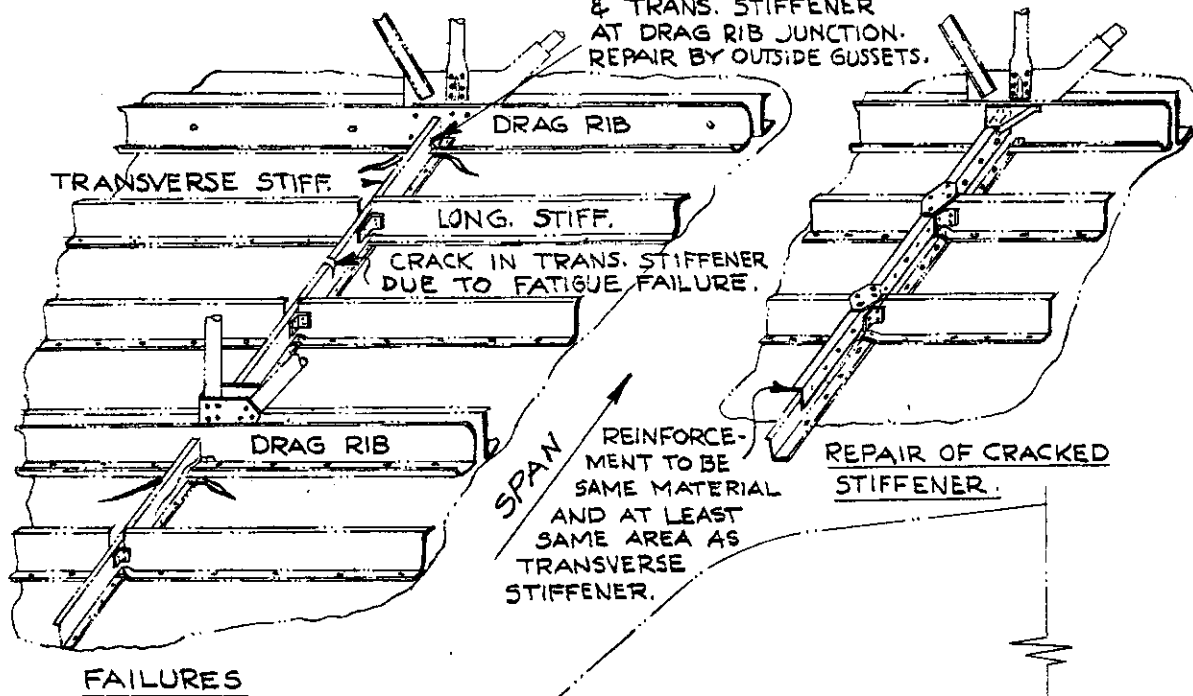
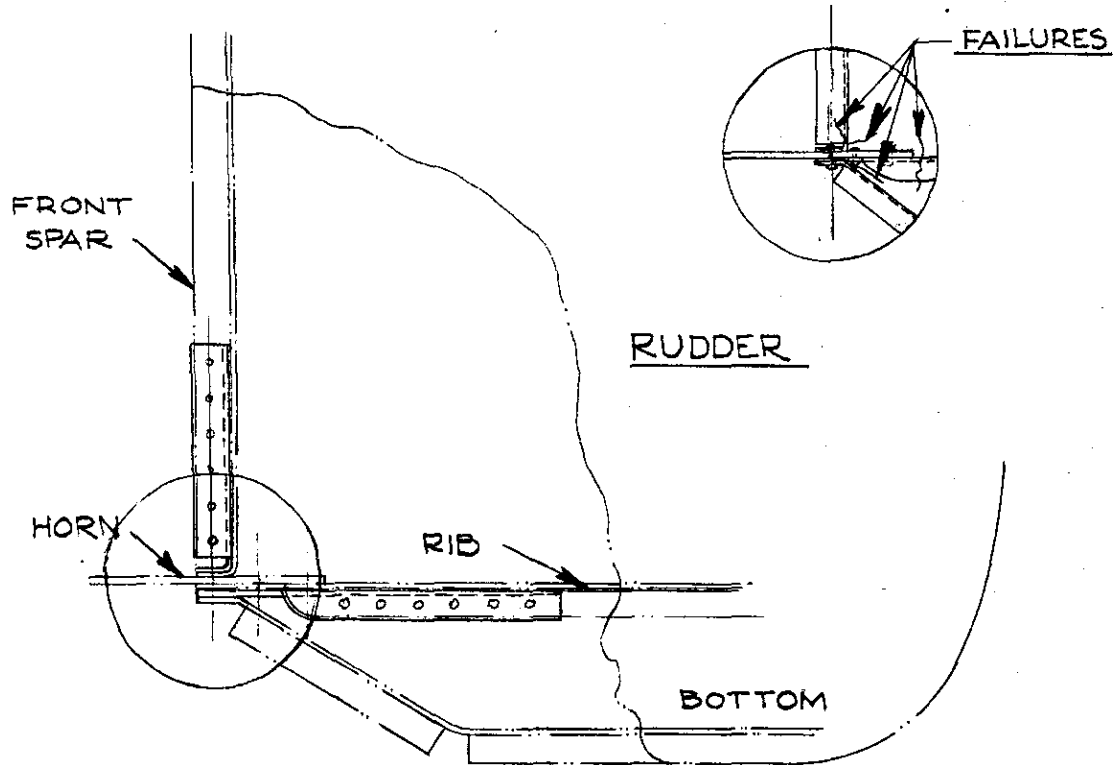

FIG. 35 - TYPICAL METHODS OF REPAIRING CRACKED FRAME AND STIFFENER COMBINATIONS.

Reference - Section 18.6448



NOTE : USE SAME MATERIAL, NEXT HEAVIER GAUGE FOR REINFORCEMENT.

FIG.36 - TYPICAL REPAIRS TO RUDDER AND TO FUSELAGE AT TAIL POST

Reference - Section 18.6448

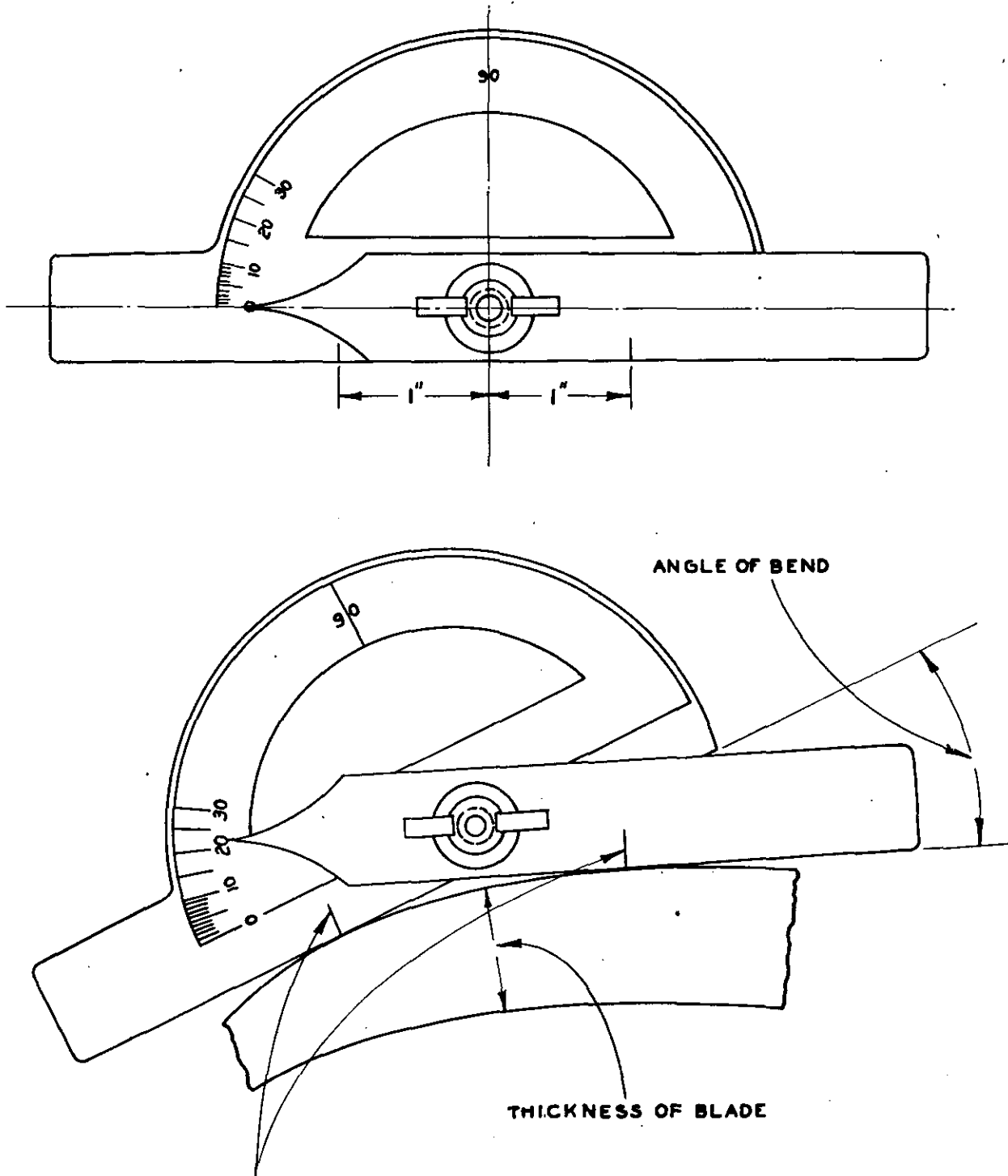

MEASURE AT A POINT OF TANGENCY TAKEN ONE INCH EACH SIDE C.L. OF BEND

FIG. 37 - PROTRACTOR AND METHOD OF MEASURING ANGLE OF BEND IN ALUMINUM ALLOY PROPELLERS.

Reference - Section 18.6821

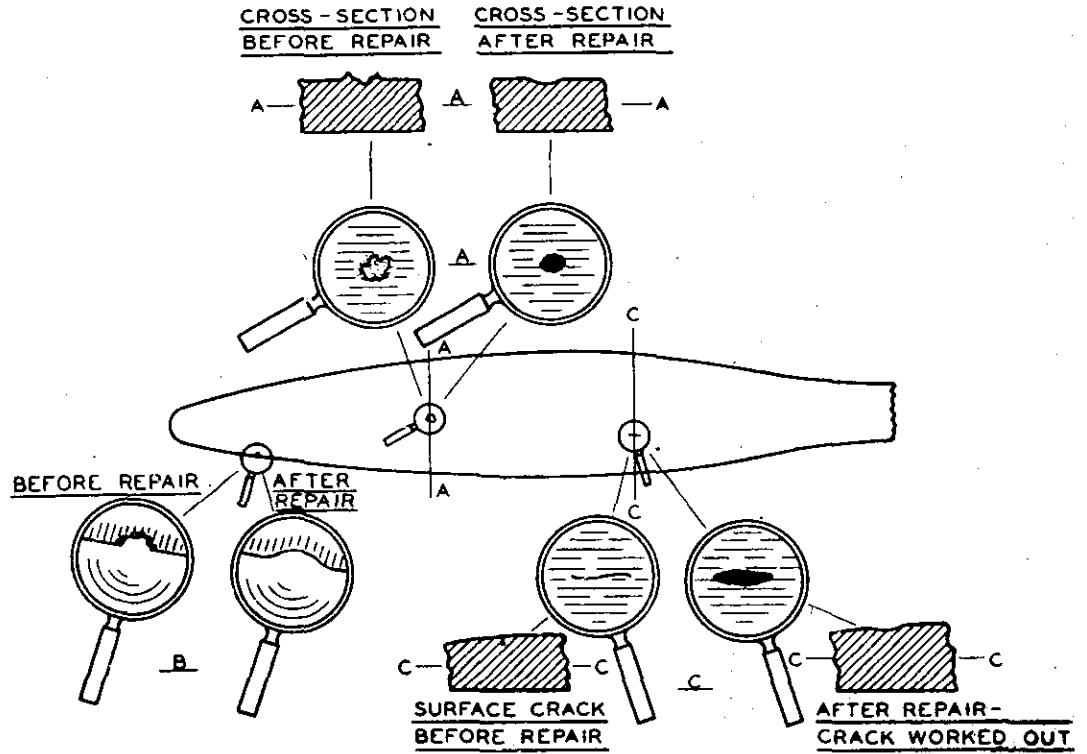

FIG. 38 - METHOD OF REPAIRING SURFACE CRACKS, NICKS, ETC.

Reference - Section 18.6825

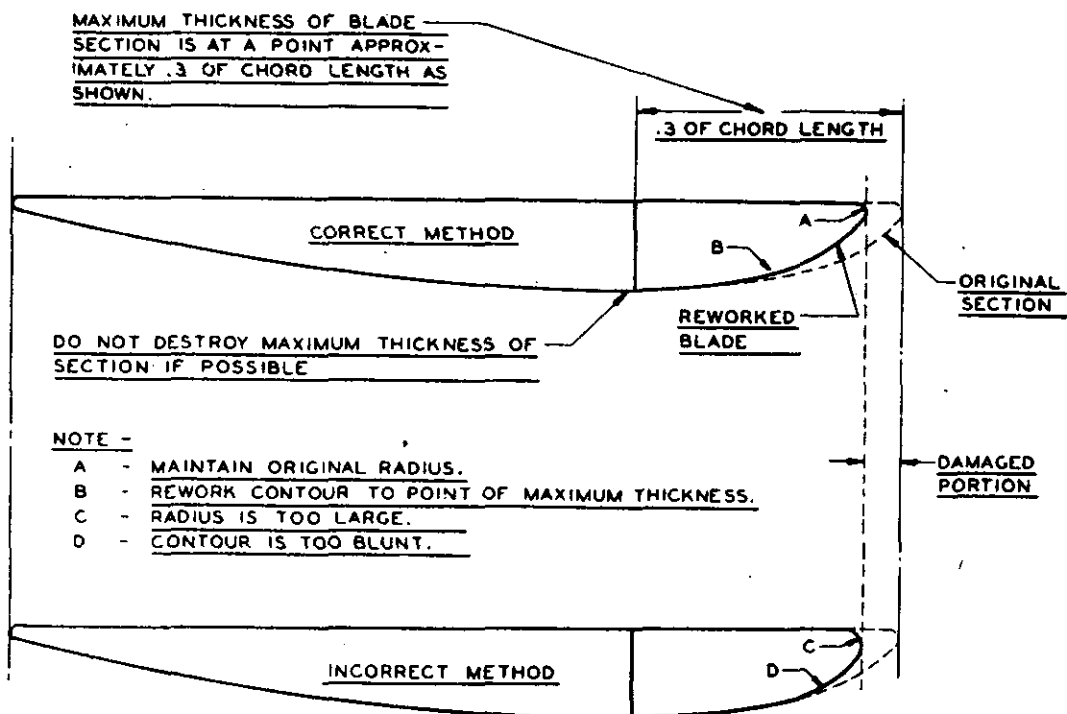

FIG. 39 - CORRECT & INCORRECT METHOD OF REWORKING LEADING EDGE

Reference - Section 18.6827

CIVIL AERONAUTICS MANUAL 18

REPAIR LIMITS TO SECTION WIDTH AND THICKNESS

FOR

ALUMINUM ALLOY PROPELLER BLADES

REDUCTIONS SHOWN ARE THE MAXIMUM ALLOWABLE BELOW THE MINIMUM DIMENSIONS REQUIRED BY THE BLADE DRAWING AND BLADE MANUFACTURING SPECIFICATION.

RADIUS - PER CENT OF REPAIRED BLADE RADIUS

0 10 20 30 40 50 60 70 80 90

REDUCTION IN WIDTH AND THICKNESS PER CENT

0 1 2 3 4 5 6 7 8 9 10 11 12 13

FIG. 40

Reference - Section 18.6827

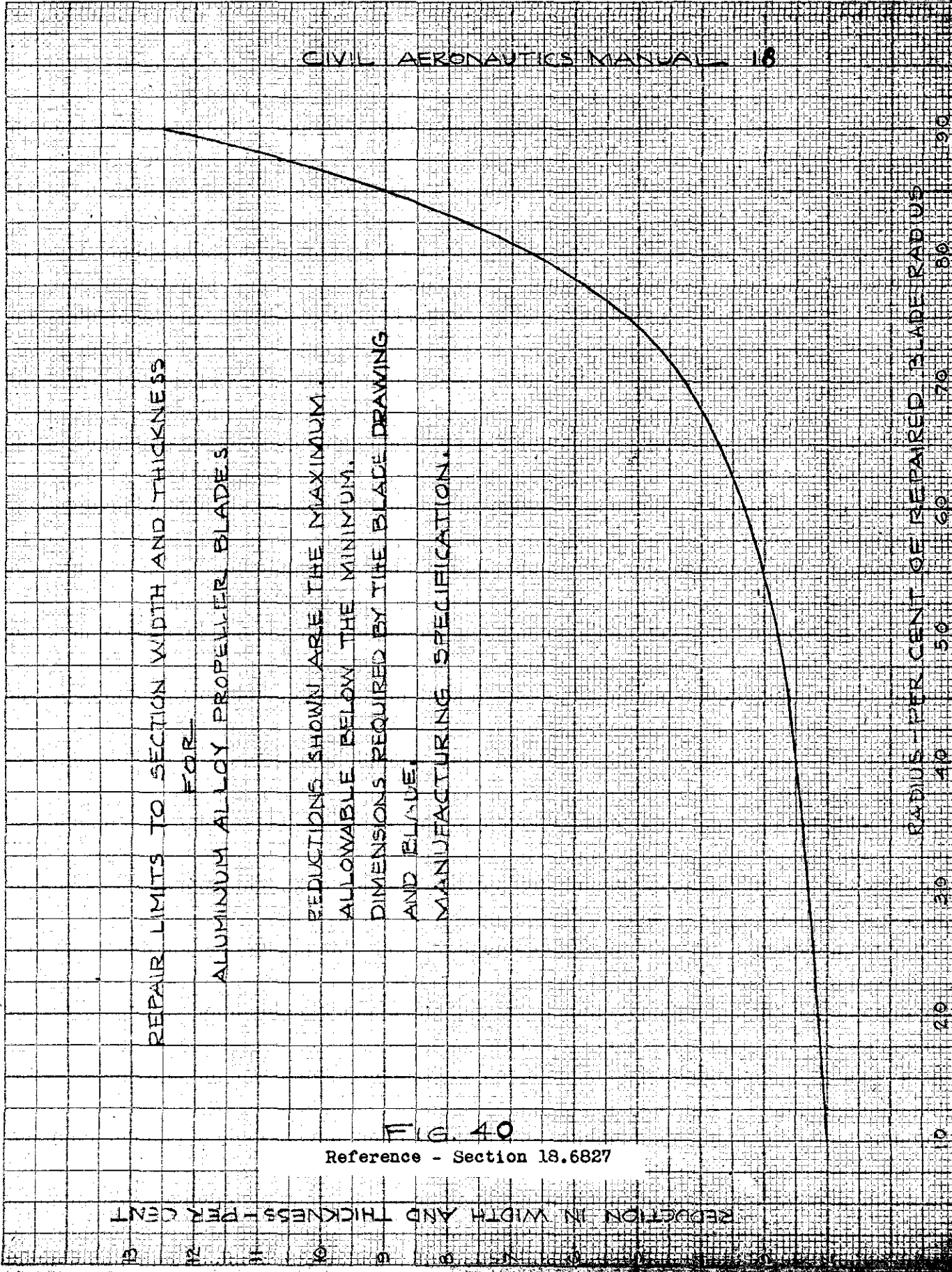

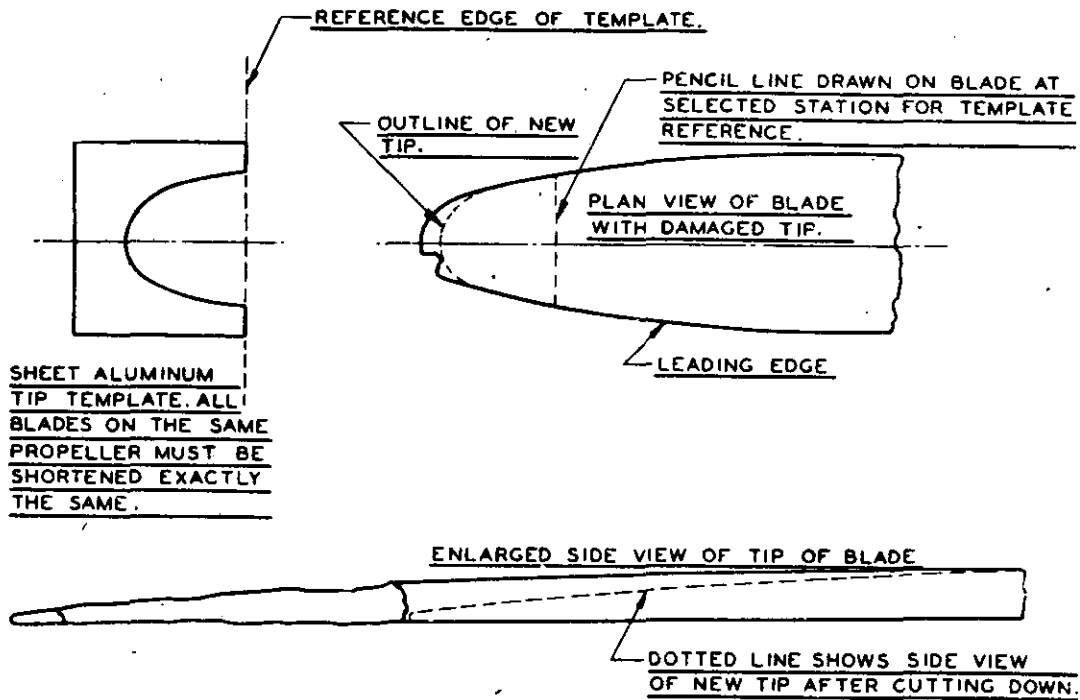

FIG. 41 - METHOD OF REPAIRING DAMAGED TIP

Reference - Section 18.6828

Table 3.—PROPERTIES OF TUBES FOR SPLICES USING OUTSIDE SLEEVES FOR CONDITIONS NOT COVERED BY TABLES 1 AND 2

[A, B, and C either SAE 1025 or 4130 steel]

Diameter		Wall thickness	
A and B	C	A and B	C
1 1/8 inches or less	Diameter A + 1/4 inch	<i>Inch</i> 0.095 or less	<i>Inch</i> 0.095
	Diameter A + 3/8 inch	0.120	.120
	Diameter A + 1/2 inch	3/32	5/32
	Diameter A + 5/8 inch	3/16	1 3/16
2 inches or more	Diameter A + 1/4 inch	0.095 or less	.095
	Diameter A + 3/8 inch	0.120	.120
	Diameter A + 1/2 inch	3/32	1 3/4
	Diameter A + 5/8 inch	3/16	1 3/4

¹ Sleeve C must be reamed to sliding fit.

Table 4.—(REFERENCE SECTION 18.6410) RECOMMENDED BEND RADII FOR 90° BEND—IN TERMS OF SHEET THICKNESS ("T")

Aluminum alloys	Specification and type	Condition	Thickness of sheet (inches) incl.					
			0.016 and under	0.018 to 0.032	0.036 to 0.064	0.068 to 0.125	0.129 to 0.188	0.203 to 0.250
17	SO	Annealed	0	0	0	0	0.5T	1T
		Heat-treated (not aged) worked within 1 hour	0.5T	0.5T	0.5T	1T	1T	1.5T
	ST	Heat-treated and aged	1T	1.5T	2T	3T	4T	5T
17 (Alclad)	SRT	Heat-treated and rolled	2T	3T	4T	5T	5T	7T
	SO	Annealed	0	0	0	0	0.5T	1T
		Heat-treated (not aged) worked within 1 hour	0.5T	0.5T	0.5T	1T	1T	1.5T
24	ST	Heat-treated and aged	1T	1.5T	2T	3T	3.5T	4T
	SRT	Heat-treated and rolled	2T	3T	4T	5T	5T	6T
	SO	Annealed (A)	0	0	0	0	0.5T	1T
A24 (Alclad)		Heat-treated and worked within 1/4 hour	1T	1T	2T	2.5T	3T	4T
	ST	Heat-treated (T)	2.5T	3.5T	4.5T	5T	6T	7T
	SRT	Heat-treated and rolled (TR)	3T	4T	5T	6T	7T	9T
52	SO	Annealed (A)	0	0	0	0.5T	1T	2T
		Heat-treated and worked within 1/4 hour	1T	1T	2T	2.5T	3T	4T
	ST	Heat-treated (T)	2T	3T	4T	5T	6T	7T
53	SRT	Heat-treated and rolled (TR)	2.5T	3.5T	4T	5T	6T	7.5T
	SO	Soft (A)	0	0	0	0	0	0
	S 1/4 H	Quarter hard (1/4 H)	0	0	0	0.5T	0.5T	1T
58	S 1/2 H	Half-hard (1/2 H)	0	0	0.5T	1T	1.5T	2.5T
	S 3/4 H	Three-quarter hard (3/4 H)	0.5T	1T	1.5T	2.5T	3.5T	4T
	SH	Hard (H)	1T	1.5T	2.5T	3T	4T	5T
58	SO	Annealed (A)	0	0	0	0	0	0
	SW	Quenched (W)	0.5T	1T	1.5T	2.5T	3T	4T
	ST	Heat-treated and aged (T)	1T	1.5T	2.5T	3T	4T	5T

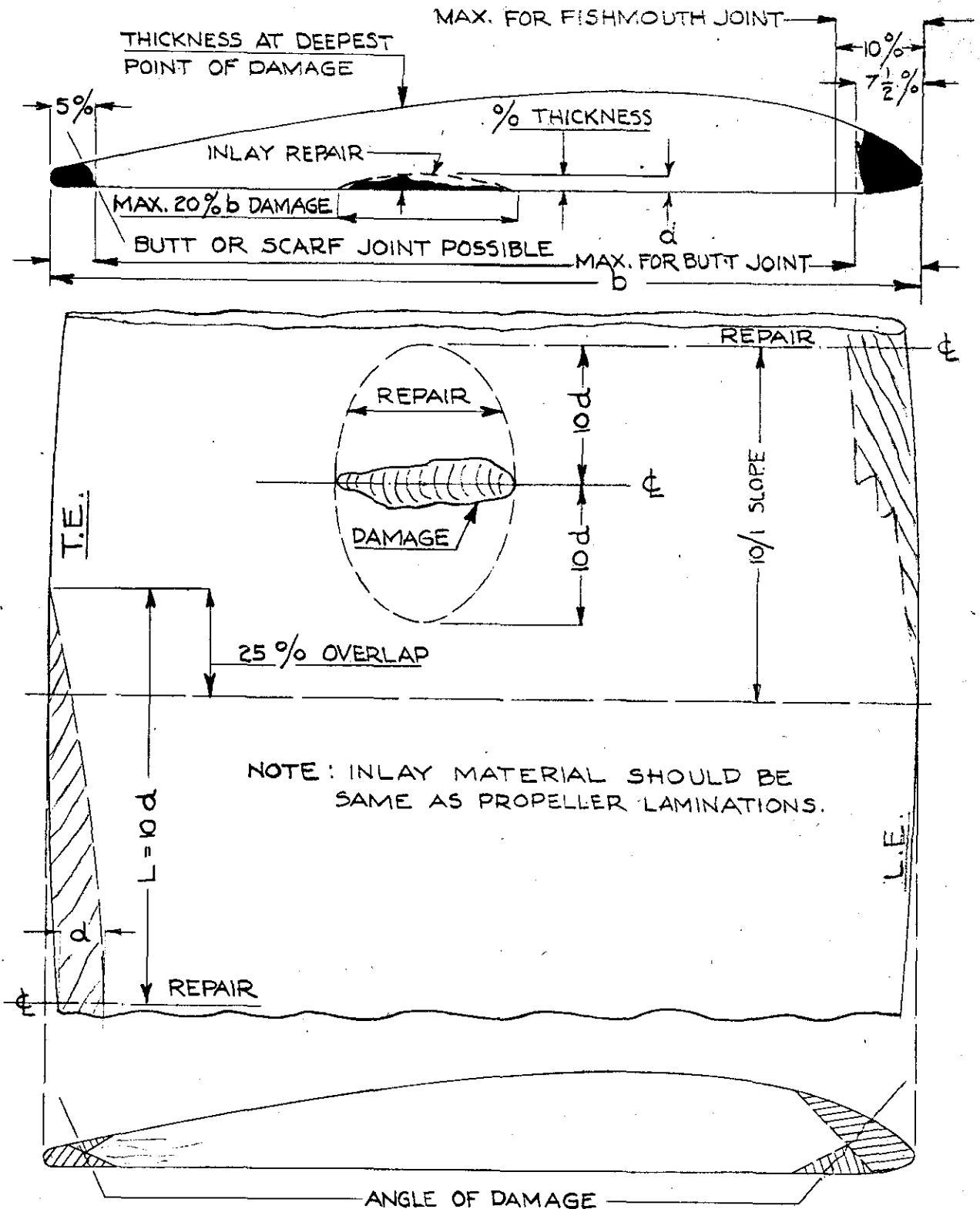
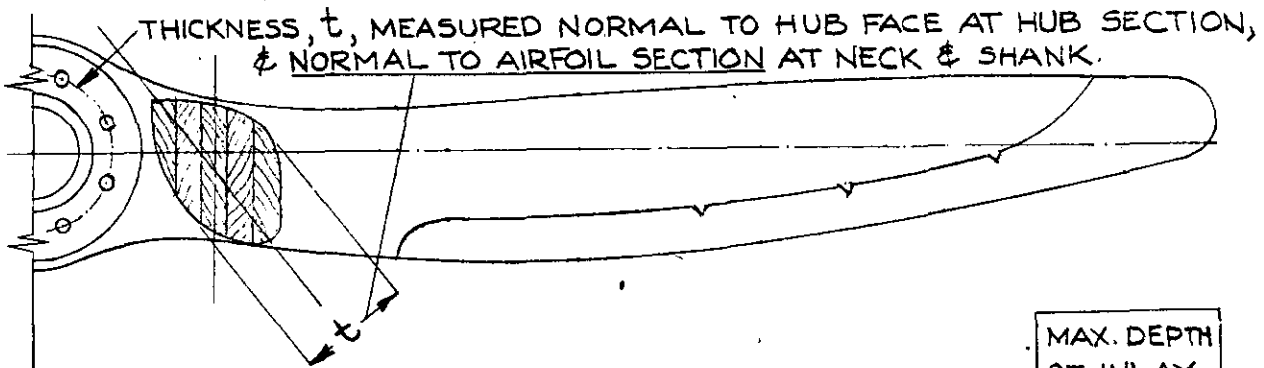

FIG. 42 - PROPELLER REPAIR BY ADDITION OF SMALL INLAY

Reference - Section 18.6853, 18.6855



	MAX. DEPTH OF INLAY, % OF THICKNESS t
 <p>HUB, NECK & SHANK PROPORTIONATELY HEAVY.</p>	<p>$7 \frac{1}{2}$</p>
 <p>SMALL HUB & EXCESSIVELY SMALL NECK & SHANK.</p>	<p>$2 \frac{1}{2}$</p>
 <p>SMALL HUB & HEAVY NECK & SHANK</p>	<p>5</p>

FIG. 43 - SPLICING PROPELLER LAMINATIONS.

Reference - Section 18.6854

Table 5.—ROCKWELL TENSILE STRENGTH RELATIONS

Rockwell conversion chart: Brale penetrator (diamond point)—“A” scale 60KG, “C” scale 150KG, “D” scale 100KG. Ball penetrator—“B” $\frac{1}{16}$ inch 100KG, “E” $\frac{1}{8}$ inch 100KG, “F” $\frac{1}{16}$ inch 60KG, “H” $\frac{1}{8}$ inch 60KG]

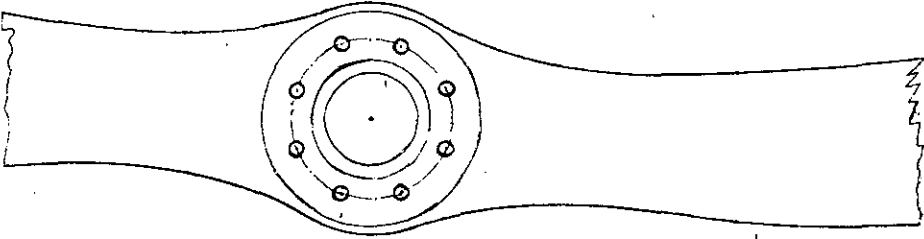
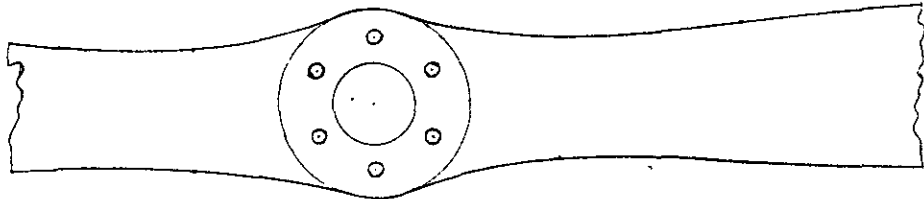
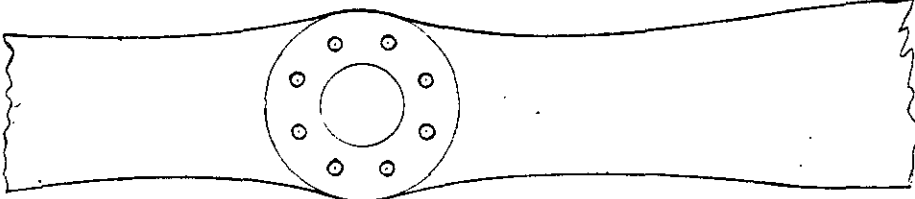
Tensile pound per square inch	Brale		Ball				Tensile pound per square inch	Brale				Tensile pound per square inch	Brale				Ball
	“A”	“B”	“E”	“F”	“H”	“A”		“C”	“D”	“B”	“A”		“C”	“D”	“B”		
30,000		3	58	59	88	80,700	52	1		85	129,500	63	26	44	103		
32,000		10	62	63	90	81,500	52	2		85	133,000	64	27	45	104		
34,000	20	15	65	65	92	82,800	53	3		86	135,000	64	28	46	105		
36,000	23	22	70	69	95	84,000	53	4		87	139,500	65	29	47	106		
38,000	25	28	73	73	97	85,000	54	4		88	142,500	65	30	47	106		
40,000	28	33	76	75	99	87,000	54	5		88	146,000	66	31	48	107		
42,000	30	38	79	78		88,000	54	6		88	150,000	66	32	49	108		
44,000	32	43	82	81		89,200	55	7		89	153,000	67	33	50	109		
46,000	34	47	85	84		90,600	55	8		89	158,000	67	34	50	110		
48,000	35	50	87	85		91,500	56	9		90	162,500	68	35	51	111		
50,000	37	54	89	87		93,800	56	10		91	167,500	68	36	52	111		
52,000	38	57	91	89		95,000	56	11		91	173,500	69	37	53	113		
54,000	39	60	93	91		95,800	56	12		92	179,500	69	38	54	114		
56,000	40	62	94	92		98,500	57	13		93	186,000	70	39	54	115		
58,000	42	65	96	94		100,500	57	14		94	193,000	70	40	55	116		
60,000	42	67	97	95		102,400	58	15		95	200,000	71	41	56	117		
62,000	43	69	99	96		104,600	58	16		96	206,500	71	42	57			
64,000	44	71	100	97		106,800	59	17		96	213,400	72	43	57			
66,000	45	73		98		109,000	59	18		97	221,000	72	44	58			
68,000	46	75		99		110,000	59	19		97	231,500	73	45	59			
70,000	47	76				113,200	60	20	40	98	236,600	73	46	60			
72,000	48	78				115,800	61	21	41	99	245,500	74	47	60			
74,000	49	80				118,500	61	22	41	100	255,500	74	48	61			
76,000	50	81				121,200	62	23	42	101	263,500	75	49	62			
78,000	50	82				124,000	62	24	43	102	273,000	76	50	63			
80,000	52	84				126,500	63	25	44	102	283,000	76	51	64			

Table 6.—TEXTILE MATERIALS AND SUPPLIES USED IN AIRPLANE COVERING

Material	Specification No.	Use	Fiber	Yarn size	Threads per inch	Tensile strength (minimum)	Normal weight	Sizing (maximum) (per cent)	Remarks
Airplane fabric	AN-CCC-C-399-1	Covering for any aircraft fabric surface. When wing loading is less than 11 rsf and design gliding speed (111 percent placard glide or dive speed) is less than 240 mph. Intermediate or light-weight fabric as specified below may be used.	Cotton	60 2-ply warp and fill.	80-84 in both warp and fill.	80 pounds per inch warp and fill (strip test).	4 ounces per square yard.	2.5	
CAA grade A airplane fabric.	CAM 04.415-A1	do	do	Optional—single or 2-ply.	80-84 in both warp and fill.	do	Optional	2.5	
CAA lightweight airplane fabric.	CAM 04.415-A2	Covering for components of light airplanes whose wing loadings are 8 rsf or less and whose design gliding speeds are 150 mph or less (light airplanes).	do	Optional—single ply.	110 maximum in both warp and fill.	50 pounds per inch warp and fill (strip test).	do	2.5	
Intermediate airplane fabric.	CAM 04.415-A3	Covering for components of light airplanes whose wing loadings and design speeds are between limitations noted for grade A and light-weight fabrics (straight line variation).	do	Optional—single or 2-ply.	Straight line variation between 84 and 110. (See "Use.")	Straight line variation between 80 and 50 pounds per inch (See "Use.")	do	2.5	
Surface tape.	CAM 04.415-A7	Over seams, leading edges, trailing edges, outer edges and ribs.	do	Same as fabric used.	Same as fabric used.	Same as fabric used.		2.5	Pinked, scalloped or straight edges.
Reinforcing tape.	CAM 04.415-A4, 5, 6 or AN-DDD-T-91.	Under rib lacing cord.	do	Optional	Optional	For use with grade A fabric—150 pounds light weight—75 pounds.	Optional	3.5	Tensile strength given for ½ inch width only. Other widths approximately in proportion.
Lacing cord.	6-Z, 6-203-A, 15-9, or CAM 04.415-A8.	Lacing fabric to structure.	Cotton or linen.	do		80 pounds double (minimum for all types).			Unless already waxed, must be lightly waxed before using.
Machine thread.	V-T-276-B	All machine sewing.	Cotton.	20 4-ply		5 pounds.	5,000 yards per pound.		
Hand sewing thread.	V-T-276-B Type III B.	All hand sewing.	do	8 4-ply		14 pounds.	1,650 yards per pound.		

APPENDIX I

EXAMPLES AND METHODS OF SHOWING COMPLIANCE WITH THE REQUIREMENTS IN CASE OF SPECIAL REPAIRS INVOLVING ALUMINUM ALLOY STRUCTURES

A. GENERAL CONSIDERATIONS WHEN RIVETING.

1. As outlined in the manual, when replacing rivets the original size should be used if this size will fit and fill the holes. If not, the holes should be drilled or reamed for the next larger size rivet, care being taken, however, that the edge distances and spacings are not less than the minimums shown in figure II. A general rule for the diameter of rivets used to join dural sheets is to use a diameter approximately three times the thickness of the sheet, or somewhat larger for thin sheet. Dimensions for formed flat rivet heads are shown in figure I.
2. A new or revised rivet pattern should be designed for the strength required, but in general practice the spacing should not be closer than the minimums shown in figure II. Rivets should not be used where they would be placed in tension tending to pull the heads off. A lap joint of thin sheets should be "Backed up" by a stiffening section.

B. RIVETING TECHNIQUE.

1. Rivet holes should be drilled, round, straight, and free from cracks. The snap used in driving the rivets should be cupped slightly flatter than the rivet head (fig. I). Rivets should be driven straight and tight, but not overdriven or driven while too hard, since the finished rivet must be free from cracks. Information on special methods of riveting, such as flush riveting, may usually be obtained from manufacturer's service manuals.

C. SPLICING OF SHEETS.

1. In some cases the method of copying the seams at the edges of a sheet may not be satisfactory, for example when the sheet has cut-outs, or doubler plates at an edge seam, or when other members transmit loads into the sheet. In these cases, the splice should be designed to carry the full allowable tension load for the sheet as illustrated in the following example:

Material: 17ST Alclad Sheet, 0.032 inch thickness.

Width of sheet (i. e. length at splice) = "W" = 10 inches.

To determine rivet size and pattern for a single lap joint, similar to figure II:

- a. Choose diameter the nearest size larger than three times the sheet thickness according to section A above. $3 \times 0.032 = 0.096$ inch. Use $\frac{1}{8}$ A17St rivets.
- b. Determine the number of rivets required per inch of width, "W," from table II. Number per inch = 5.9. Total number of rivets required = $10 \times 5.9 = 59$ rivets.
- c. Lay-out rivet pattern with spacings not less than those shown in figure II. Referring to figure II (b), it is seen that a 4-row pattern with the center rows spaced $\frac{1}{2}$ inch and the outer rows 1 inch will give a total of 60 rivets in the 10-inch splice, and is therefore satisfactory.

D. SPLICING OF STRINGERS.

Typical splices for various shapes of sections are shown in figures III and IV. Stringers are designed to carry both tension and compression and the splice shown in figure IV will be used as an example illustrating the following general principles:

1. To avoid eccentric loading and consequent buckling in compression, splicing or reinforcing parts should be placed as symmetrically as possible about

- the centerline of the member and attachment made to as many elements as necessary to prevent bending in any direction.
2. To avoid reducing the strength in tension of the original bulb angle, the rivet holes at the ends of the splice are made small (no larger than the original skin attaching rivets), and the second row of holes (those through the bulbed leg) are staggered back from the ends.
 3. To avoid concentration of load on the end rivet and consequent tendency toward progressive rivet failure, the splice is tapered off at the ends, in this case by tapering the backing angle and by making it shorter than the splice bar. (See fig. IV.)

The preceding principles are especially important in splicing stringers on the lower surface of stressed skin wings, where high tension stresses may exist. When several adjacent stringers are spliced, the splices should be staggered if possible.

1. *Size of splicing members.* When the same material is used for the splicing member as for the original member, the net cross sectional area (i. e., the shaded areas in fig. III) of the splicing member should be greater than the area of the section element which it splices. The area of a section element (e. g. each leg of an angle or channel) is equal to the width multiplied by the thickness. For example, in figure IV, the bar, "B" is assumed to splice the upper leg of the stringer, and the angle "A" to splice the bulbed leg of the stringer. Since the splice bar "B" is not as wide as the adjacent leg, and since the rivet diameter is also subtracted from the width, the bar is made twice as thick in order to obtain sufficient net area.
2. *The diameter of rivets in stringers.* The diameter of rivets in stringers should preferably be between two and three times the thickness, "t", of the leg, but should not be more than one-fourth the width, "W," of the leg. Thus, $\frac{1}{8}$ -inch rivets are chosen in the example, figure IV. If this splice were in the lower surface of a wing, the end rivets would be made the same size as the skin attaching rivets, say $\frac{3}{16}$.
3. *The number of rivets.* The number of rivets required on each side of the cut in the stringer may be found from tables I, II, or III as the case may be. In determining the number of rivets required in the example, figure IV, for attaching the splice bar, "B" to the upper leg, the thickness "t" of the element of area being spliced is $\frac{1}{16}$ inch (use 0.064), the rivet size is $\frac{1}{8}$ inch, and table II shows that 11.5 rivets are required per inch of width. Since the width, "W," is $\frac{1}{2}$ inch, the actual number of rivets required to attach the splice bar to the upper leg, on each side of the cut, is 11.5 (rivets per inch) $\times .5$ (inch width) $= 5.75$, use 6 rivets.

For the bulbed leg of the stringer, "t"— $\frac{1}{16}$ (use 0.064), AN3 ($\frac{3}{16}$) bolts are chosen, and the number of bolts required per inch of width $= 3.9$. The width "W" for this leg, however, is 1 inch, and the actual number of bolts required on each side of the cut is $1 \times 3.9 = 3.9$, use 4 bolts. When both rivets and bolts are used in the same splice, the bolt holes should be accurately reamed to size. It is preferable to use only one type of attachment, but in the above example, the dimensions of the legs of the bulb angle indicated rivets for the upper leg and bolts for the bulb leg.

E. SPLICING OF INTERMEDIATE FRAMES.

The same principles that are used for stringer splicing may be applied to intermediate frames, when the following points are also considered:

1. Conventional frames of channel or Z section are relatively deep and thin compared to stringers, and usually fail by twisting or by buckling of the free flange. The splice joint should be reinforced against this type of failure by using a splice plate heavier than the frame and by splicing the free flange

of the frame with a flange on the splice plate, as illustrated in figure V. Since a frame is likely to be subjected to bending loads, the length of splice plate "L" should be more than twice the width, "W₂," and the rivets spread out to cover the plate.

Table I.—NUMBER OF RIVETS REQUIRED FOR SPLICES (SINGLE LAP JOINT) IN 24ST, 24ST ALCLAD, 24SRT AND 24SRT ALCLAD SHEET

Thickness "t" in inches	Number of A17ST rivets required per inch of width "W"					
	3/32	1/8	5/32	3/16	1/4	3/16 bolts (AN-3)
0.016	7.4	5.6				
0.020	7.4	5.6	4.5			
0.025	9.0	5.6	4.6			
0.032	11.5	6.5	4.5	3.7		
0.036	13.0	7.3	4.7	3.7	2.8	
0.040	14.4	8.1	5.2	3.7	2.8	
0.051		10.3	6.6	4.6	2.8	
0.064		13.0	8.3	5.8	3.2	
0.081			10.5	7.3	4.1	3.7
0.091			11.8	8.2	4.6	3.7
0.102			13.2	9.2	5.2	3.7
0.128				11.5	6.5	3.8

NOTES.—(a) For stringers in the upper surface of a wing, or in a fuselage, 80 percent of the number of rivets shown in the table may be used.
 (b) For intermediate frames, 60 percent of the number shown may be used.

ENGINEERING NOTES.—The above table was computed as follows:

1. The load per inch of width of material was calculated by assuming a strip 1 inch wide in tension at a stress of 62,000 pounds per square inch, which is slightly unconservative for 24SRT and conservative for 24ST Alclad and 24SRT Alclad.
2. Number of rivets required was calculated for A17ST rivets, using allowable stress values of 25,000 pounds per square inch in shear, and a value in bearing calculated on the basis of a ratio between ultimate tensile strength and ultimate bearing strength of 1.43.
3. Combinations of sheet thickness and rivet size above the double line are critical in (i. e., will fail by) bearing on the sheet; those below are critical in shearing of the rivets.

Table II.—NUMBER OF RIVETS REQUIRED FOR SPLICES (SINGLE LAP JOINT) IN 17ST, 17ST ALCLAD, 17SRT AND 17SRT ALCLAD SHEET

Thickness "t" in inches	Number of A17ST rivets required per inch of width "W"					
	3/32	1/8	5/32	3/16	1/4	3/16 bolts (AN-3)
0.016	7.8					
0.020	7.8	5.9				
0.025	8.0	5.9				
0.032	10.2	5.9	4.7	3.9		
0.036	11.5	6.5	4.7	3.9		
0.040	12.8	7.2	4.7	3.9	2.9	
0.051		9.2	5.9	4.1	2.9	
0.064		11.5	7.4	5.1	2.9	3.9
0.081		14.6	9.3	6.5	3.6	3.9
0.091			10.4	7.2	4.2	3.9
0.102			11.7	8.1	4.6	3.9
0.128			14.7	10.2	5.7	3.9

NOTES.—(a) For stringers in the upper surface of a wing, or in a fuselage, 80 percent of the number of rivets shown in the table may be used.
 (b) For intermediate frames, 60 percent of the number shown may be used.

ENGINEERING NOTES.—The above table was computed as follows:

1. The load per inch of width of material was calculated by assuming a strip 1 inch wide in tension at a stress of 55,000 pounds per square inch, which is slightly conservative for 17SRT Alclad and 17ST Alclad.
2. Number of rivets required was calculated for A17ST rivets, using allowable stress values of 25,000 pounds per square inch, in shear, and a value in bearing calculated on the basis of a ratio between ultimate tensile strength and ultimate bearing strength of 1.56.
3. Combinations of sheet thickness and rivet size above the double line are critical in (i. e., will fail by) bearing on the sheet; those below are critical in shearing of the rivets.

**Table III.—NUMBER OF RIVETS REQUIRED FOR SPLICES (SINGLE LAP JOINT) IN 52S
(ALL HARDNESSES) SHEET**

Thickness "t" in inches	Number of A17ST rivets required per inch of width "W"					
	$\frac{3}{32}$	$\frac{1}{8}$	$\frac{5}{32}$	$\frac{3}{16}$	$\frac{1}{4}$	$\frac{3}{16}$ bolts (AN-3)
0.016.....	6.0	-----	-----	-----	-----	-----
0.020.....	6.0	4.5	-----	-----	-----	-----
0.025.....	6.0	4.5	-----	-----	-----	-----
0.032.....	7.3	4.5	3.6	-----	-----	-----
0.036.....	8.2	4.6	3.6	3.0	-----	-----
0.040.....	9.1	5.1	3.6	3.0	2.2	-----
0.051.....	11.6	6.5	4.2	3.0	2.2	-----
0.064.....	14.5	8.2	5.2	3.6	2.2	-----
0.081.....	-----	10.3	6.6	4.6	2.6	-----
0.091.....	-----	11.6	7.4	5.1	2.9	3.0
0.102.....	-----	13.0	8.3	5.8	3.2	3.0
0.128.....	-----	-----	10.4	7.2	4.1	3.0

NOTES.—(a) For stringers in the upper surface of a wing, or in a fuselage, 80 percent of the number of rivets shown in the table may be used.
(b) For intermediate frames, 60 percent of the number shown may be used.

ENGINEERING NOTES.—The above table was computed as follows:

1. The load per inch of width of material was calculated by assuming a strip 1 inch wide in tension at a stress of 39,000 pounds per square inch, which is slightly conservative for the $\frac{3}{4}$ hard, $\frac{1}{2}$ hard, and $\frac{1}{4}$ hard material.
2. Number of rivets required was calculated for A17ST rivets, using allowable stress values of 25,000 pounds per square inch in shear, and a value in bearing calculated on the basis of a ratio between ultimate tensile strength and ultimate bearing strength of 1.78.
3. Combinations of sheet thickness and rivet size above the double line are critical in (i. e. will fail by) bearing on the sheet; those below are critical in shearing of the rivets.

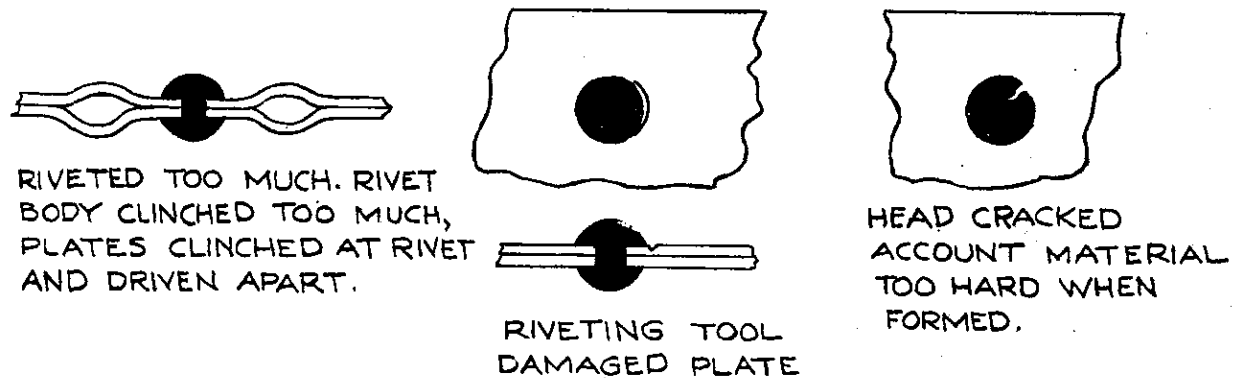
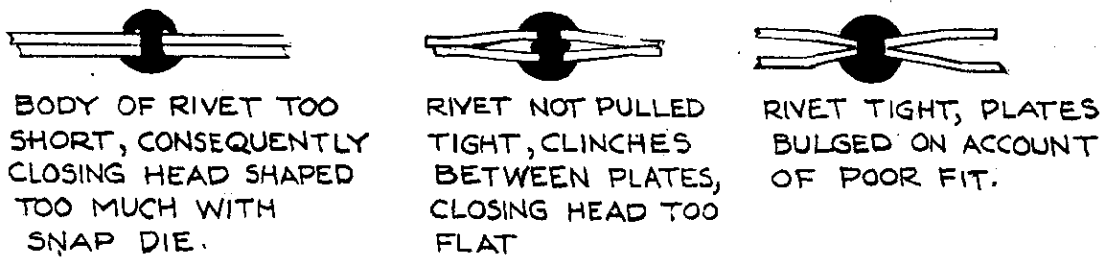
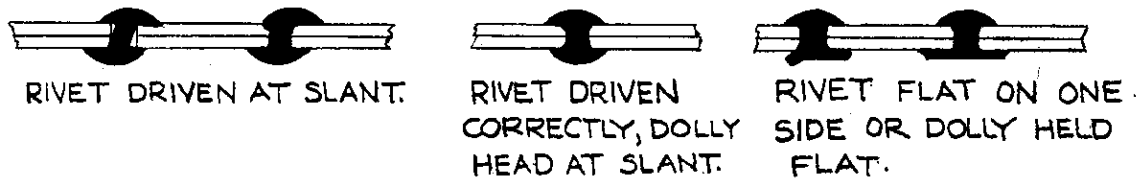
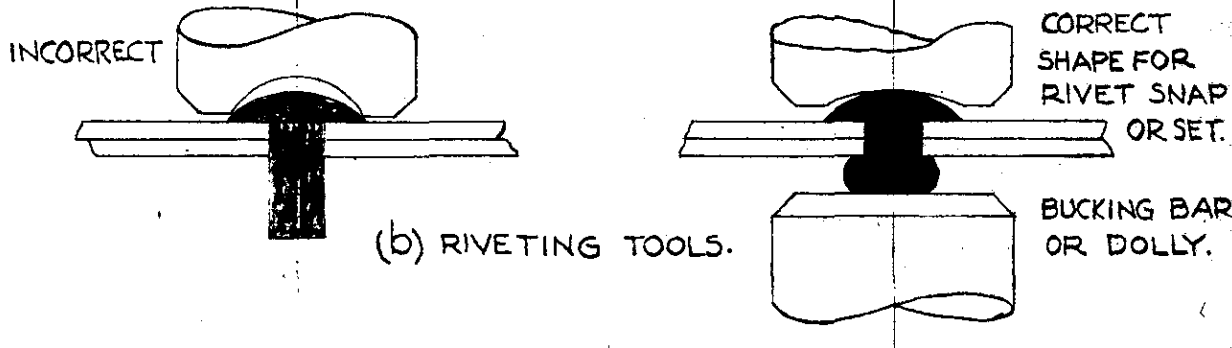
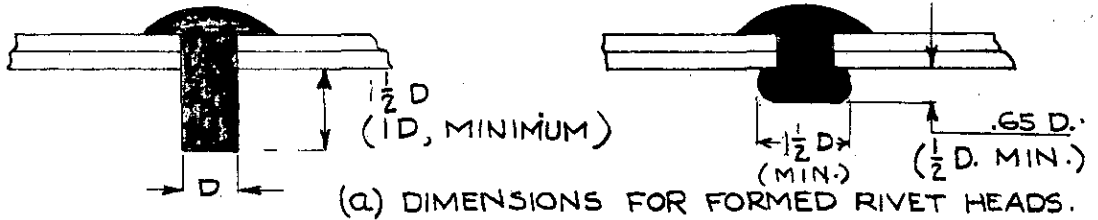
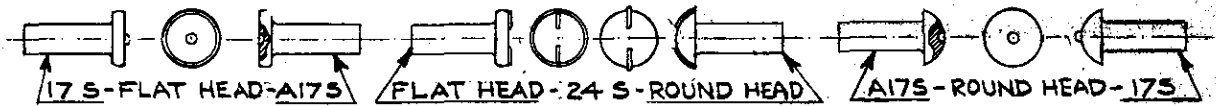

(c) RIVET IMPERFECTIONS.

FIG. I - RIVETING PRACTICE & RIVET IMPERFECTIONS.

STRENGTH THROUGH THIS SECTION IS 66% OF SHEET WITHOUT HOLES

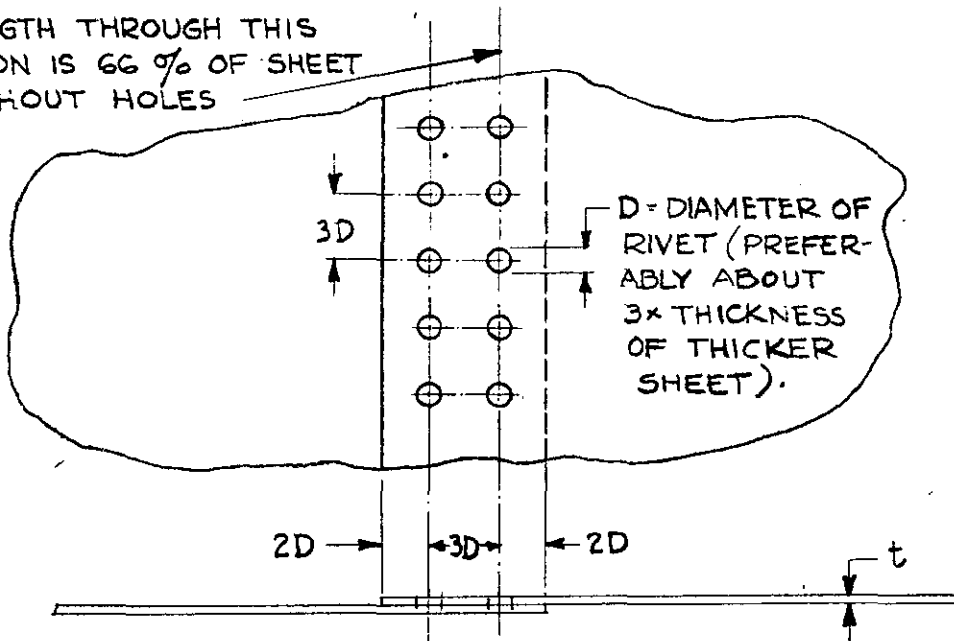

(a) SINGLE OR DOUBLE ROWS

STRENGTH THROUGH THIS SECTION IS 83% OF SHEET WITHOUT HOLES.

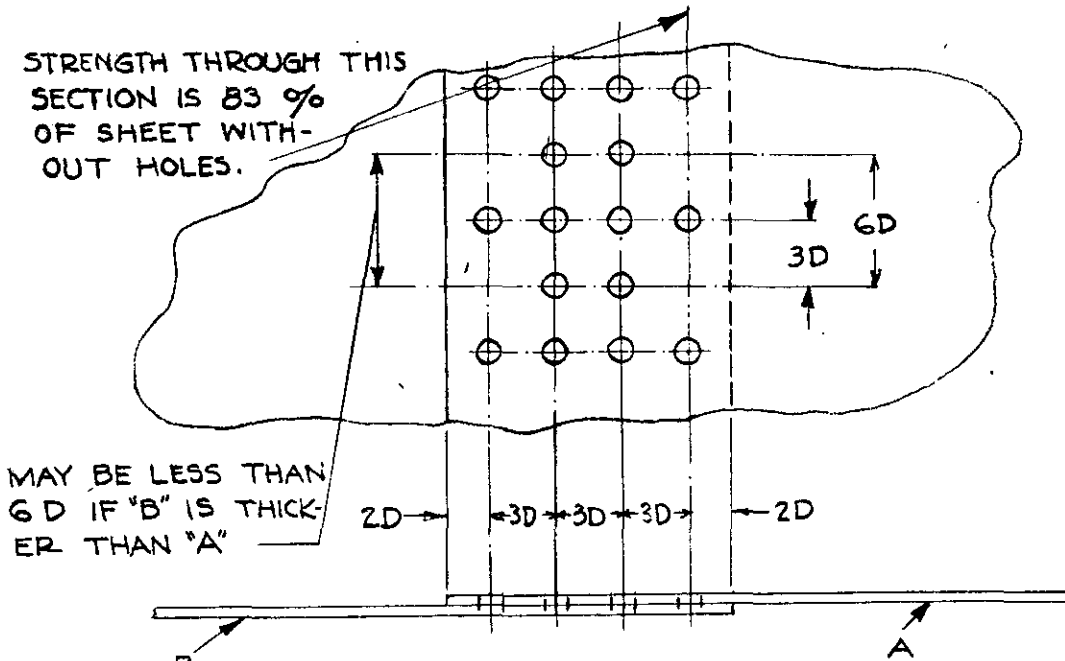

(b) MULTIPLE ROWS

FIG. II - RIVET HOLE SPACING AND EDGE DISTANCE

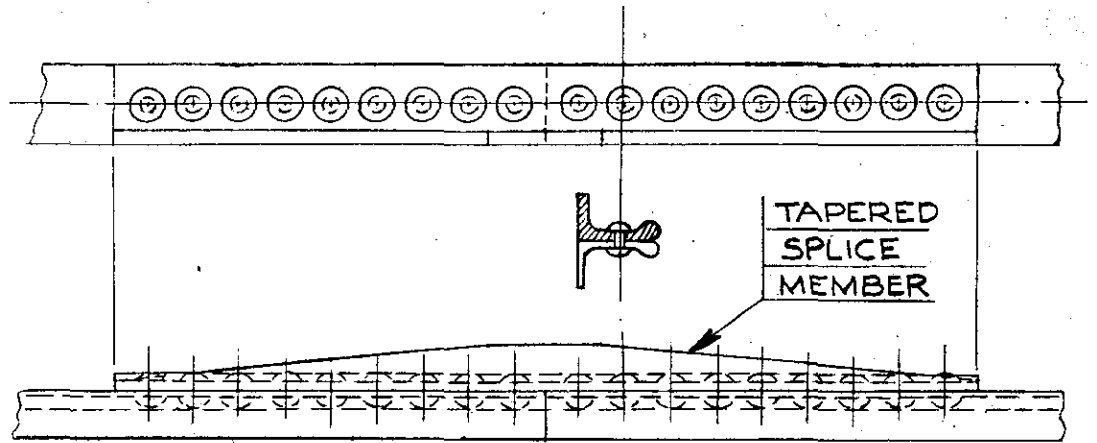

NOTE: UNSHADED SECTIONS ARE ORIGINAL AND/OR REPLACEMENT SECTIONS. SHADED SECTIONS ARE CONNECTING OR REINFORCING SECTIONS.

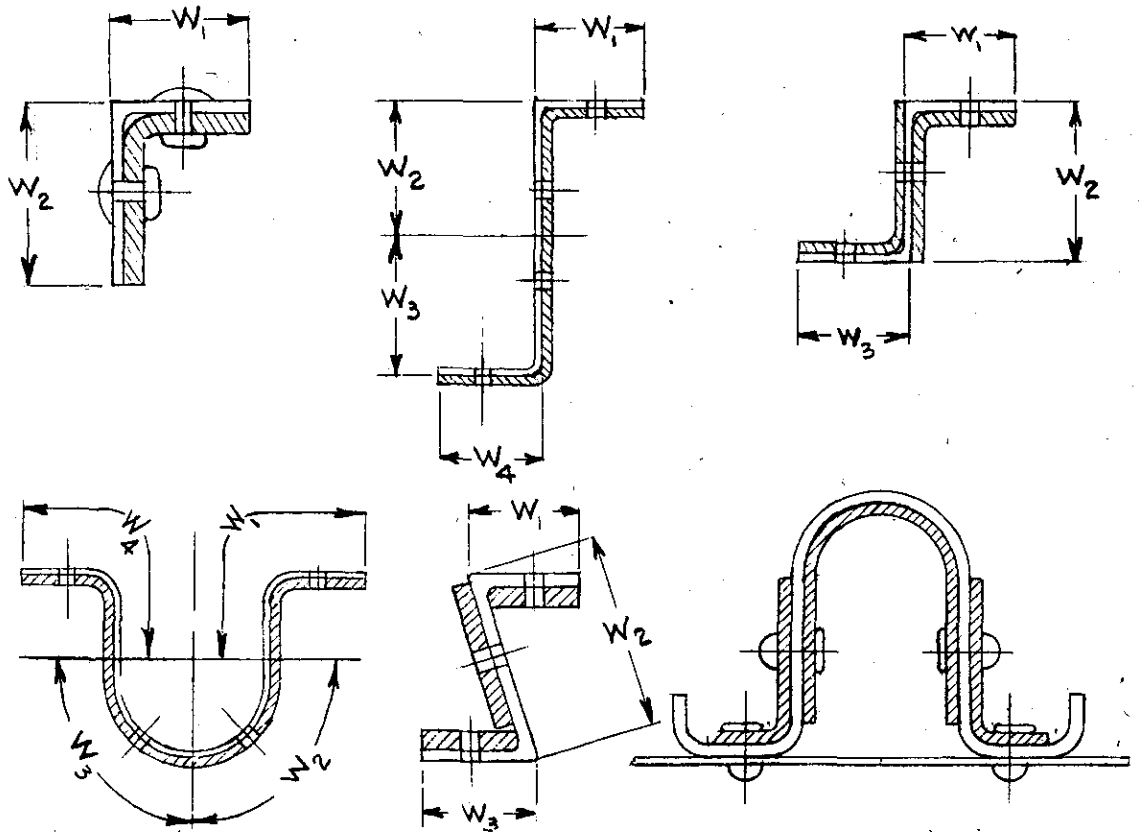
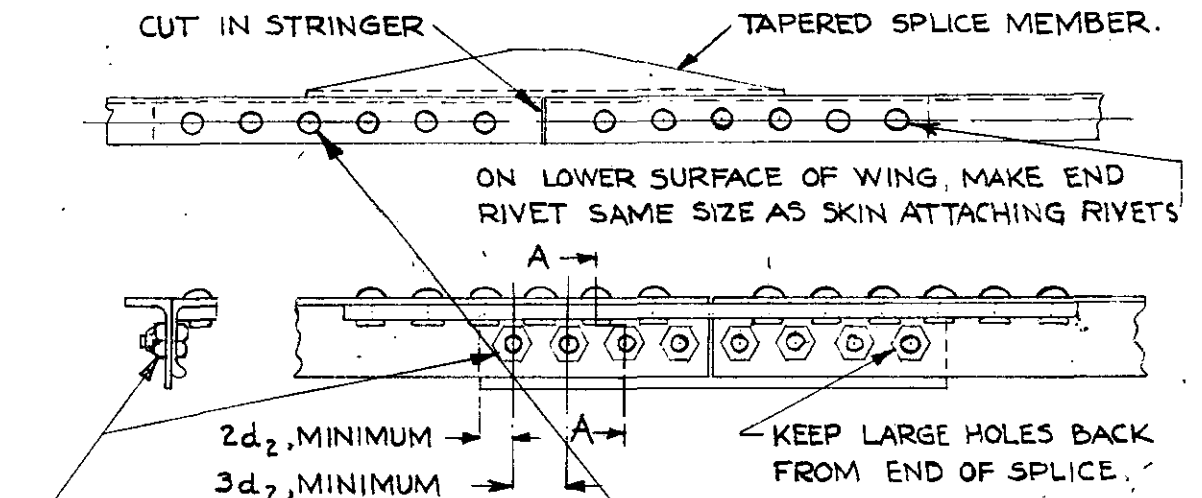

FIG III - TYPICAL STRINGER AND FLANGE SPLICES.



THE NUMBER OF BOLTS REQUIRED IN THE 'BULB' LEG OF THE STRINGER IS DETERMINED FROM TABLE II FOR 17ST AS FOLLOWS:

$$t_2 = \left(\frac{1}{16}\right), \text{ (USE .064)}$$

$$d_2 = \left(\frac{3}{16}\right), \text{ AN3 BOLT}$$

NO. OF BOLTS PER INCH OF WIDTH FROM TABLE = 3.9

ACTUAL NO. OF BOLTS ON EACH SIDE OF CUT = $W_2 \times 3.9$

$$= (1.0) \times 3.9 = 3.9 \text{ BOLTS}$$

USE 4 BOLTS

THE NUMBER OF RIVETS REQUIRED IN THE UPPER LEG OF THE STRINGER IS DETERMINED FROM TABLE II FOR 17ST AS FOLLOWS:

$$t_1 = \left(\frac{1}{16}\right), \text{ (USE .064)}$$

$$d_1 = \left(\frac{1}{8}\right), \text{ A17ST RIVET}$$

NO. OF RIVETS PER INCH OF WIDTH FROM TABLE = 1.5

ACTUAL NO. OF RIVETS ON EACH SIDE OF CUT = $W_1 \times 1.5$

$$= (.5) \times 1.5 = 5.75 \text{ RIVETS}$$

USE 6 RIVETS.

WHEN BOTH RIVETS & BOLTS ARE USED, BOLT HOLES SHOULD BE REAMED TO SIZE

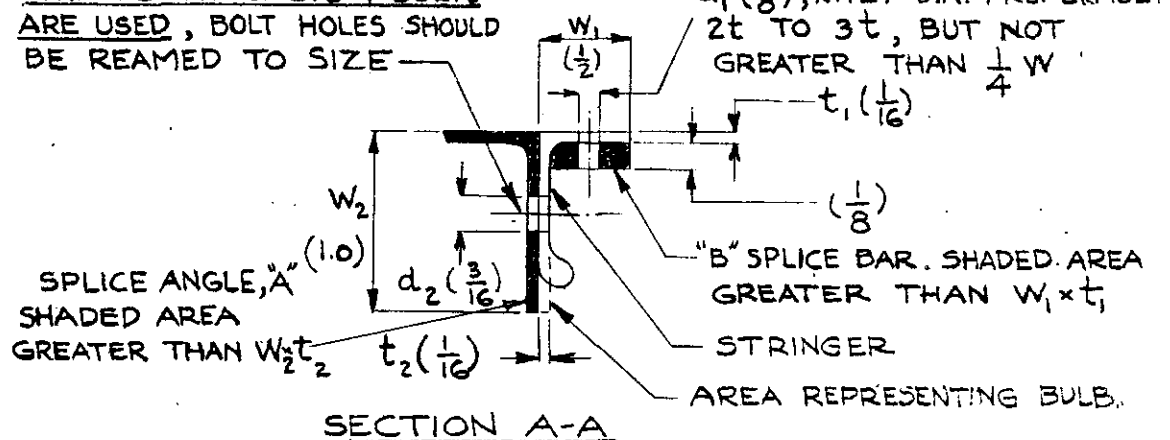
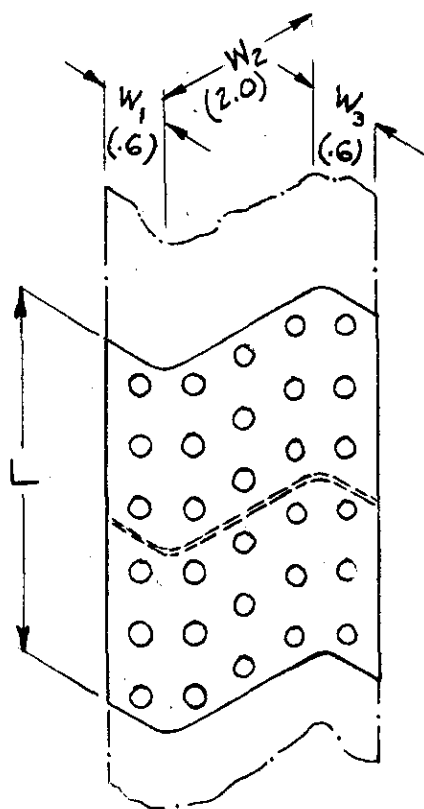

FIG. IV - EXAMPLE OF STRINGER SPLICE (MATERIAL - 17ST AL. ALLOY)

THE NUMBER OF RIVETS REQUIRED IN EACH LEG ON EACH SIDE OF THE CUT IS DETERMINED BY THE WIDTH "W", THICKNESS OF FRAME MATERIAL "t" AND RIVET DIAMETER "d", USING TABLE II (FOR 17ST)

IN A MANNER SIMILAR TO THAT FOR STRINGERS, FIG. IV
NOTE (b), TABLE II, INDICATES THAT ONLY 60% OF THE NUMBER OF RIVETS SO CALCULATED NEED BE USED IN SPLICES IN INTERMEDIATE FRAMES

EXAMPLE :-



FLANGE LEG

$$t = (.032)$$

$$d_1 = \left(\frac{1}{8}, \text{A17ST RIVET}\right)$$

$$W_1 = (.6) \text{ IN.}$$

NO. OF RIVETS PER IN. OF WIDTH,
FROM TABLE II (FOR 17ST) = 5.9

$$\text{NO. OF RIVETS IN LEG} = W_1 \times 5.9$$

$$= (.6) \times 5.9 = 3.54, \text{ SAY 4 RIVETS}$$

$$60\% \text{ OF } 4 = .6 \times 4 = 2.4 \text{ RIVETS}$$

USE 3 RIVETS, EACH SIDE OF CUT.

BACK OF ZEE (OR CHANNEL)

$$t = (.032)$$

$$d_2 = \left(\frac{1}{8}, \text{A17ST RIVET}\right)$$

$$W_2 = 2.0 \text{ INS.}$$

NO. OF RIVETS PER IN. OF WIDTH
FROM TABLE = 5.9

$$= (2) \times 5.9 = 11.8, \text{ SAY 12 RIVETS}$$

$$60\% \text{ OF } 12 = .6 \times 12 = 7.2 \text{ RIVETS.}$$

USE 8 RIVETS, EACH SIDE OF CUT.

"L" SHOULD BE AT LEAST TWICE W_2 .
THICKNESS OF SPLICE PLATE GREATER THAN THAT
OF FRAME.

FIG. V. - EXAMPLE OF SPLICE OF INTERMEDIATE FRAME.
(MATERIAL - 17ST AL. ALLOY)

APPENDIX II

INFORMATION ON WEIGHING PROCEDURE AND CHECK OF BALANCE FOR ALTERATIONS

(Supersedes IP-10 and Pars. 106-113 of Ch. XI, Inspection Handbook)

A. GENERAL.

The information contained herein has been prepared as an aid to aircraft owners in obtaining approval of alterations to certificated aircraft.

It is the responsibility of the owner, operator, or repair agency to furnish all data specified in CAR 18 and CAM 18. In addition to the required detail drawings, sketches, or analyses, such data may need to include a check of the critical balance condition showing that the approved C. G. limits will not be exceeded.

In view of the fact that weight and balance data on older aircraft are usually very meager or of questionable accuracy, it is considered advisable to weigh such aircraft whenever practicable in order to establish a rational basis for subsequent weight control. Inasmuch as it has been established that aircraft in general have a tendency to pick up weight in service, weighing would automatically account for such variation.

Although, *in general, this is merely a recommended practice*, it should be noted that *weighing may be required in certain cases for the purpose of establishing the actual empty weight*, useful load and center of gravity when alterations of an extensive nature are made.

B. DEFINITIONS.

1. *MAC* or mean aerodynamic chord. The chord of an imaginary airfoil used in aerodynamic computations.
2. *Datum*. A plane or line in a plane used as a reference in order to show relative locations of objects. In these computations, the datum is vertical and is usually tangent to the leading edge of the wing or some convenient bulkhead (with aircraft in level flight attitude). To avoid possible confusion, the datum noted on the pertinent aircraft specification will be used when given. In any case, the datum used should be properly identified in each set of computations submitted.
3. *Center of gravity*. The C. G. of an aircraft may be defined, for the purpose of balance computations, as an imaginary point about which the noseheavy (-) and tail-heavy (+) moments are exactly equal in magnitude. Thus, the aircraft, if suspended therefrom, would have no tendency to rotate in either direction (nose up or down). (See fig. 3.) The weight of the aircraft (or any object) may be assumed to be concentrated at its center of gravity.

The C. G. with useful load installed is allowed to range fore and aft within certain limits which are determined during the flight tests for type certification as those which are the most forward and most rearward loaded C. G. positions at which the aircraft will meet the Civil Aeronautics performance and flight characteristics requirements respectively. These limits are indicated on the pertinent Aircraft Specification (for current models) in percent of the MAC or in inches aft of the datum.

4. *Arm* (or moment arm) is the horizontal distance in inches to the C. G. of an item measured (plus) aft of and (minus) forward of, the datum.

On current Aircraft Specifications the arm of various items is included (in parentheses) immediately following its name or weight. When such information is not available, it must be obtained by actual measurement.

5. *Moment* is the product of a weight and its arm. Thus, the moment of an item about the datum is obtained by multiplying the weight of the item by its horizontal distance from the datum.

Moment manifests itself as a tendency to cause rotation of the aircraft about its C. G. and is represented, in figures, by a circular arrow indicating the direction of the tendency. (See par. H.1.)

6. *Minimum fuel* (for balance purposes) equals $\frac{1}{2}$ gallon per maximum except take-off

$$\text{horsepower} = \frac{\text{total HP}}{12}$$

7. *Equipment*. Current aircraft specifications list three classes of equipment as follows:

Class I. Required equipment which must be installed unless replaced by either a Class II or III equivalent item (such items then to be marked "required" on the Aircraft Operation Record) subject to *inspection and C. G. check*.

Class II. Optional equipment which may be installed or removed subject to *inspection and check of C. G. limits*.

Class III. Optional equipment which may be installed or removed subject to inspection only, except when the airplane is already equipped with any Class II item, in which case a C. G. check must be made to determine the effect on C. G. extremes of the Class III item installation. (Note that when any Class II item is installed, all Class III items are in effect Class II.) All optional items, the C. G. of which falls with the approved C. G. limits, are automatically Class III items.

C. WEIGHING OF AIRCRAFT.

Procedure: When it is desired to obtain the actual empty weight of an aircraft, the following procedure will apply:

1. Aircraft should always be weighed inside a closed building to prevent error in scale readings due to wind.
2. If the empty weight C. G. is to be determined, the aircraft must be weighed in a level flight attitude.
3. Determine that scales are correct, then level, set at zero and note tare before placing aircraft thereon.
4. Ascertain that fuel tanks are empty.
5. Oil tank may either contain the number of gallons noted on the filler cap or be drained. When weighed with full oil, the actual empty weight equals the actual recorded weight less the weight of the oil (7.5 lbs. per gallon). All reports must indicate whether weights include full oil or oil drained, *and that fuel tanks were empty*.
6. Radiators of liquid cooled engines, water coolers, etc., will be full.
7. Special items such as tools, anchors, stakes, ropes, ambulance equipment, etc., should be in place, if to be carried as standard equipment.

Actual weight empty as equipped then equals the sum of the net scale readings less the weight of any oil included.

D. DETERMINATION OF EMPTY WEIGHT CENTER OF GRAVITY LOCATION.

1. See part C for preliminary weighing procedure.
2. Record weights and dimensions indicated below and compute C. G. as in the following hypothetical example:

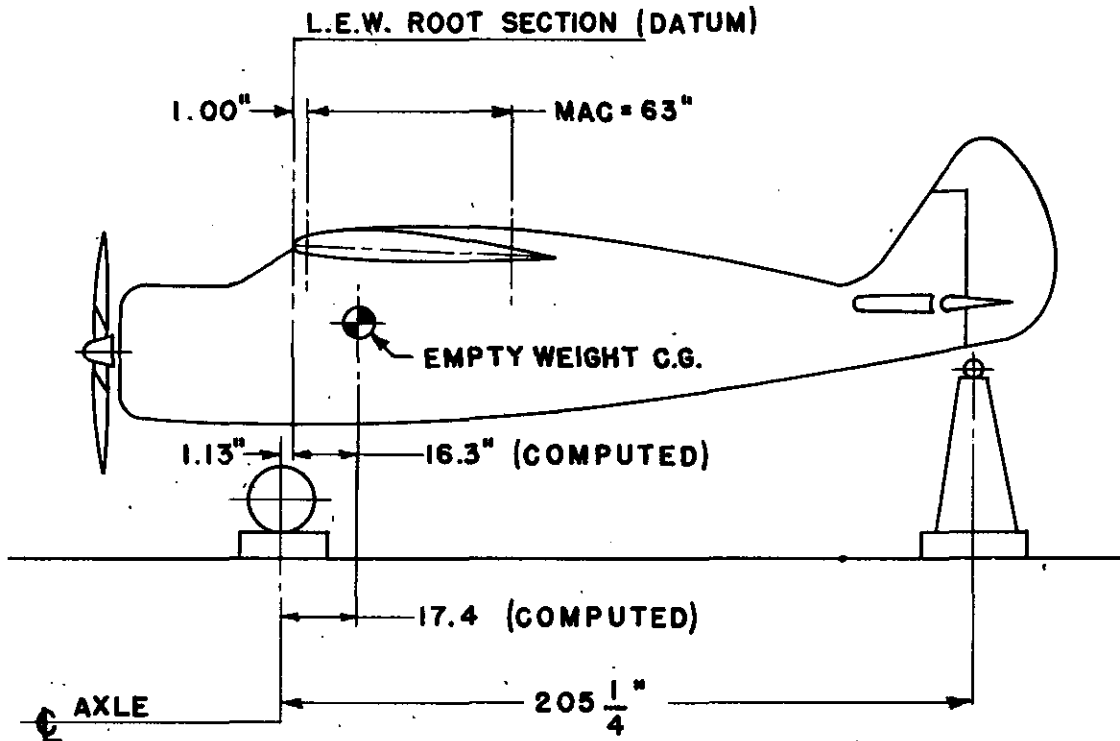

FIGURE 1.

	Scale reading	Tare	Net
	<i>Pounds</i>		<i>Pounds</i>
Left wheel.....	703	-0	703
Right wheel.....	707	-0	707
Tail wheel.....	201	-70	131
Actual weight empty (W. E.).....			1,541

The report submitted will include the following information:

Weight empty includes residual oil (system drained prior to weighing).

Weight empty includes the following equipment: (Indicate all Class I, II, III and other.) (See pertinent Aircraft Specification, or, if specification does not cover all equipment installed, a complete itemized list should be submitted.)

Item 101 to 106 inclusive (from pertinent Aircraft Specification).

Item 203. 2 special fuel tanks (30 gal. each).....pounds increase over standard... 17

Item 304. Tires (20 by 9-4).....do..... 5

Item 308. Safety glass windows.....do..... 8

Total (optional equipment).....pounds... 30

Distance of empty weight C. G. aft of wheel centerline = tail scale weight multiplied by distance between tail and main wheels divided by actual weight empty =

$$\frac{131 \times 205.25}{1541} = 17.4 \text{ inches.}$$

Distance of empty weight C. G. aft of datum = 17.4 - 1.1 = 16.3 inches.

E. APPROVED CENTER OF GRAVITY LIMITS.

1. *Current models.* Stated on pertinent aircraft specification in percent of the MAC or in inches aft of a given datum. This information may be obtained from the local Civil Aeronautics Inspector.
2. *Older models.* In the case of those models for which approved limits are not given on the specification or listing, it will usually be acceptable to assume the limits to be at 18 percent and 30 percent of the MAC for low and mid wing monoplanes and 22 percent and 34 percent of the MAC for high wing monoplanes and biplanes.

Inasmuch as several models are known to have satisfactory flight characteristics with the C. G. beyond such arbitrary positions, these should not be considered hard and fast limits. In such cases, approval will depend largely upon the recommendations of the examining inspector. The major consideration governing approval of such cases will be the relative change in the empty weight C. G. due to the alterations, rather than the absolute C. G. extremes.

If the approved forward limit thus determined is exceeded, it may be considered satisfactory provided that it is demonstrated to the local Civil Aeronautics Inspector that the aircraft can be landed in the three-point position when loaded in the extreme forward condition.

F. DETERMINATION OF MAC.

When the MAC is not known, it may be approximated closely enough for the purposes of C. G. determination, as follows:

1. In the case of a nontapered monoplane wing, the MAC may be assumed to be the same as the actual chord and the leading edge of the wing may be taken as the MAC leading edge.
2. In the case of a biplane with a rectangular or moderately staggered arrangement of nontapered wings, determine the MAC as shown by figure 2.

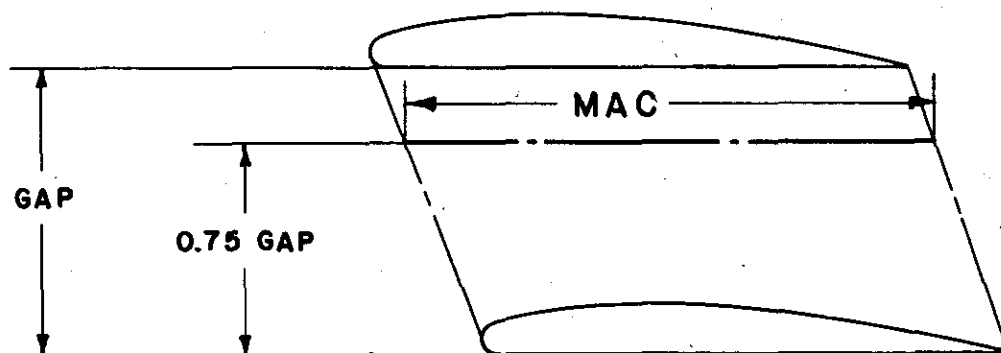

FIGURE 2.

It should be understood that this is only an approximation and when C. G. extremes expressed in percentage of an MAC thus determined seem unreasonable, the considerations outlined in the latter part of paragraph E.2. may pertain.

3. In the case of highly tapered wings, wings with considerable sweepback, or other unusual arrangements not covered by 1 or 2 above, the manufacturer should be contacted for the necessary information or calculations in accordance with Civil Aeronautics Manual 04 should be submitted.

G. DETERMINATION OF LOADED CENTER OF GRAVITY EXTREMES (The most forward and most rearward C. G. positions obtainable as equipped and with most critical distribution of useful load.)

The loaded C. G. extremes may be determined either, (1) by weighing in the two loaded conditions or, (2) by computation. Both procedures have a common objective;

namely, to demonstrate that, under the most adverse loading conditions (forward and aft), the C. G. positions will not exceed the approved limits (Part E) which have been determined by flight tests as the most extreme positions at which the model will satisfactorily comply with the Civil Air Regulations.

1. Weighing to determine C. G. extremes.

- (a) Follow preliminary weighing procedure of part C except as hereinafter modified.
- (b) The oil tank should be filled to capacity. (Wt.=7½ lbs. per gal.)
- (c) If the proposed equipment is not installed, an equivalent amount of ballast should be added at the same location prior to weighing.
- (d) Load aircraft with items of useful load or ballast simulating such items (crew and passengers at 170 lbs. each, fuel at 6 lbs. per gal., baggage, etc.) as follows:

Forward C. G. conditions:

- All items or passengers which are located ahead of the approved forward limit.
- Pilot in farthest forward seat equipped with controls (unless otherwise placarded).
- Fuel tanks ahead of approved forward limit to be filled. (If the fuel tank or tanks are to the rear of the forward limit minimum fuel should be included.)

Aft C. G. condition:

- All items or passengers which are located to the rear of the approved aft limit.
- Pilot in farthest aft seat equipped with controls (unless otherwise placarded).
- Fuel tanks to the rear of approved aft limit to be filled. (If the fuel tank or tanks are ahead of the approved aft limit, minimum fuel should be used.)

- (e) Record the weights and dimensions and compute distance of C. G. extreme aft of datum as illustrated in part D.
- (f) Check C. G. extremes thus determined against approved limits (part E).

2. Computation to determine C. G. extremes. The following computations are based upon the hypothetical 200 HP, 4 PCLM as weighed in part D.

(a) Forward C. G. extreme:

	Wt. (lbs.)	Arm	Moment
Aircraft W. E. as weighed.....	1, 541	+16. 3	25118
Pilot.....	170	+23	3910
Fuel (min.) (See par. B6.).....	100	+22	2200
Oil (3¼ gal.).....	28	-20	-560
Total.....	1, 839	-----	30668

$$\text{Forward C. G. extreme} = \frac{\text{Total moment}}{\text{Total weight}} = \frac{30668}{1839} = (+16.7)$$

Forward C. G. limit (from pertinent Aircraft Specification) (+16.5)
 Since approved limit is not exceeded, forward extreme is satisfactory.

(b) Aft C. G. extreme:

	Wt. (lbs.)	Arm	Moment
Aircraft W. E. as weighed.....	1, 541	+ 16. 3	25118
Pilot.....	170	+23	3910
Fuel.....	100	+22	2200
Oil.....	28	-20	-560
Passengers ¹ —rear (2).....	340	+48	16320
Baggage (placarded capacity).....	50	+70	3500
Total.....	2, 229	-----	50488

¹ Front passenger is omitted in both 1 and 2 since he is between approved C. G. limits in this example. Minimum fuel is used in both cases for the same reason.

$$\text{Aft C. G. extreme} = \frac{\text{Total moment}}{\text{Total weight}} = \frac{50488}{2229} = +22.6$$

Aft C. G. limit (from pertinent Aircraft Specification) (+24.6)

Since approved limit is not exceeded, aft extreme is satisfactory.

Note that the loadings in these computations agree with the rules of paragraph G-1-d.

H. CHECK OF BALANCE BY COMPUTATION.

The following data are included for the convenience of the inspectors and operators in checking the effect upon balance of adding, removing, or relocating equipment items when no information as to the balance status of the aircraft is available and if weighing is not contemplated.

For the purpose of these computations, the C. G. extreme (see pt. G) of the aircraft will be assumed to fall upon that approved limit which is critical for the change involved. (Forward limit for conditions outlined in par. H-1-b and aft limit for conditions outlined in par. H-1-a.) Although this assumption will, in certain cases, lead to unduly conservative results, it must be made when the actual empty weight C. G. is not known.

The object of such computations is to determine the resultant moment due to equipment changes or alterations in order that a compensating moment may be computed and applied. Hence, if a change is made per paragraph H-1-a, it will be necessary to apply a corresponding change per paragraph H-1-b and vice versa in order to maintain the previously satisfactory C. G. position and to prevent the possibility of exceeding the approved limit.

The following information is divided into two sections—one (1) concerns the theory of these computations while the other (2) presents several typical examples illustrating the fundamentals. It is suggested that the brief theoretical section be carefully studied and the illustrated figures memorized. When these figures are visualized, it is possible to easily and quickly compute the effect of, and compensation required for, any change or combination of changes which may subsequently be encountered.

NOTE.—Care should be exercised to insure retention of the proper algebraic sign (+ or -) throughout all balance computations and to always visualize the aircraft (for sake of uniformity in these computations) with the nose to the left. (See par. B-4.)

1. Graphic representation of basic weight and balance concepts.

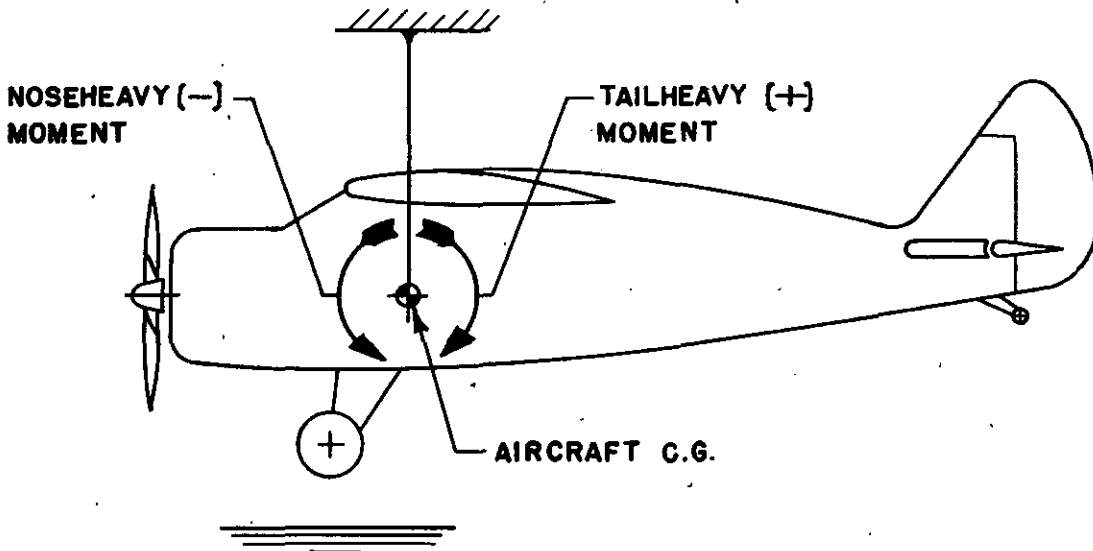

Figure 3 - Forces Acting Upon Suspended Aircraft

(a) Items removed forward of or added aft of the aircraft C. G. have the effect of increasing the tail-heavy (+) moment and thus of decreasing the nose-heavy (-) moment. This will upset the required equilibrium illustrated in figure 3 and cause the C. G. to move aft and the nose to rise. Therefore, a compensating change of the type illustrated in paragraph (b) should be applied.

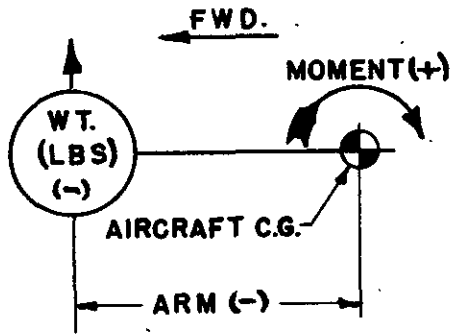

Fig. 4(a) Item removed forward.

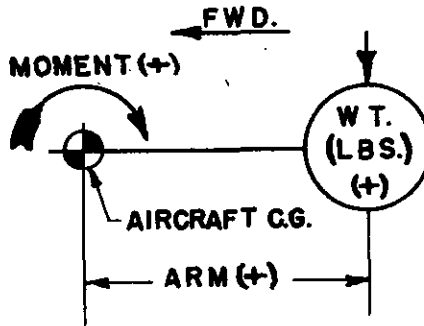

Fig. 4(b) Item added aft.

(b) Items added forward of or removed aft of the aircraft C. G. have the effect of increasing the nose-heavy (-) moment and thus of decreasing the tail-heavy (+) moment. This will upset the required equilibrium illustrated in figure 3 and cause the C. G. to move forward and the nose to drop. Therefore, a compensating change of the type illustrated in paragraph (a) should be applied.

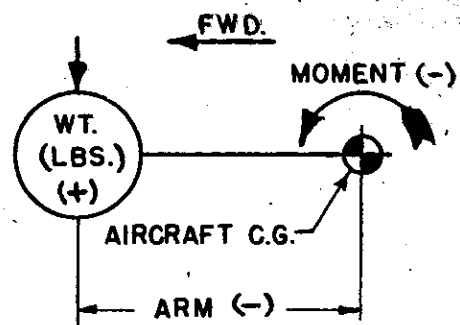

Fig. 5(a) Item added forward.

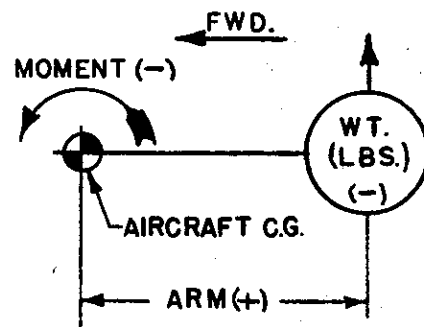

Fig. 5(b) Item removed aft.

2. Examples.

Case I. The operator of a Stinson SR-8D desires to install two special type pilot chairs.

Given: Weight empty = 2,538 pounds (from Aircraft Operation Record).

Actual weight increase due to special chairs 20 pounds (+18)

C. G. limits (+17.1) and (+27) (Specification No. 609, A-580).

Datum—wing L. E. (Specification No. 609, A-580).

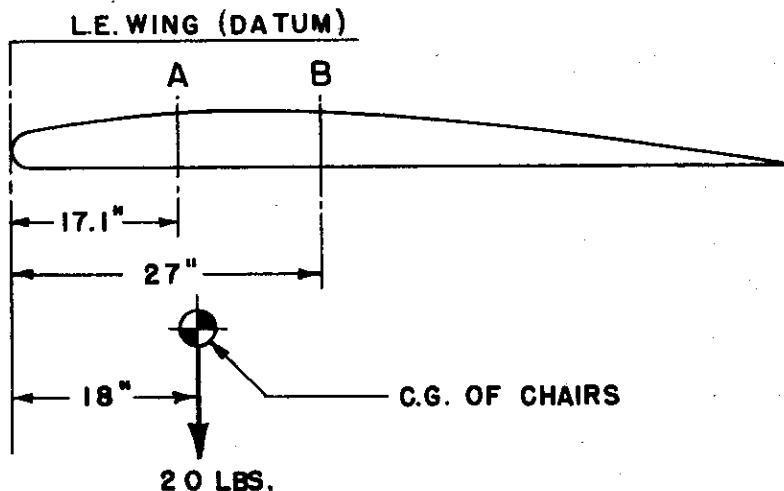

Figure 6

Find: Compensating changes required to prevent aircraft C. G. from exceeding approved limits.

Solution: If aircraft loaded C. G. is assumed to be at the forward limit (A), the chairs are aft of the C. G. and thus tend to decrease nose-heavy moment. (See fig. 4 (b).) If the aircraft loaded C. G. is assumed to be at the aft limit (B), the chairs are ahead of the C. G. and thus tend to decrease tail-heavy moment. (See fig. 5 (a).)

Conclusion: It may therefore be concluded that the addition of any item or combination of items whose C. G. falls within the aircraft approved limits is satisfactory from a balance standpoint without the necessity of a C. G. check.

Case II (a). An operator desires to install flares in a Howard DGA-15P. (see fig. 4 (b).)

Given: (Specification No. 717 (A-915)) Datum—wing L. E.
 Item 202 flares—25 pounds (+108).
 Baggage capacity—125 pounds (+84).
 C. G. limits—(+10.5) and (+21.8)
 C. G. limit affected is "B."

To find: Baggage reduction necessary to prevent possibility of aft loaded C. G. extreme from exceeding approved aft limit (B).

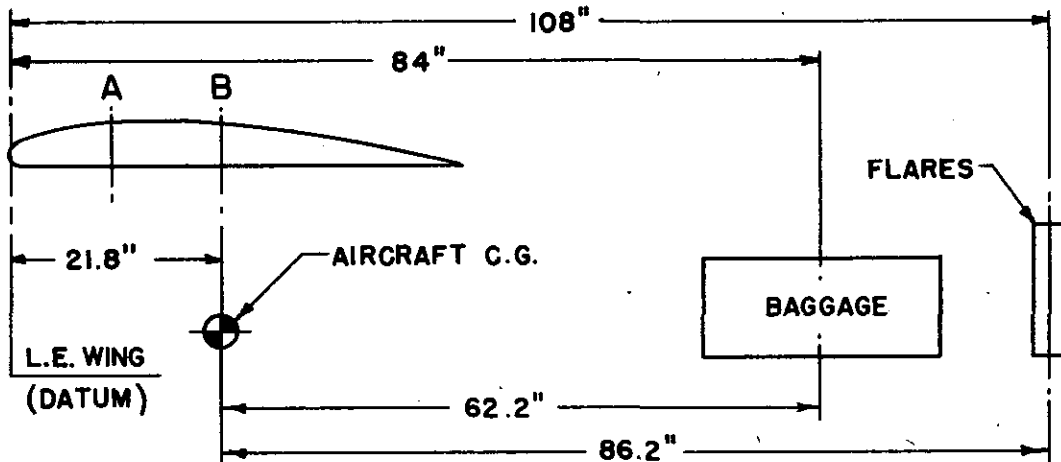

Figure 7

- Solution: (1) Assume aircraft C. G. to fall upon "B," the C. G. limit affected by a change of this type. (See fig. 4 (b).)
 (2) Compute arm of baggage and flares about "B" by subtracting 21.8 inches from arms about datum.
 (3) Moment about aft limit due to addition of flares = 86.2 inches \times 25 pounds = +2,155 inches-pounds.
 (4) Baggage reduction necessary to prevent shift of C. G. due to addition of flares = $\frac{+2,155}{62.2} = 34.6$ or (35) pounds.
 (5) Placard compartment for reduced capacity of 125 - 35 = 90 pounds.

(b) A battery is to be removed from a Rearwin 8090. (See fig. 4(a).)

Given: (Specification 711 (A-941)) Datum—wing leading edge.

Battery (item 201a)—31 pounds (-19).

Baggage—50 pounds (+44).

C. G. limits—(+13) and (+17.5).

To find: Baggage reduction necessary to prevent possibility of aft loaded C. G. extreme exceeding the approved aft limit (B). (C. G. affected is "B".)

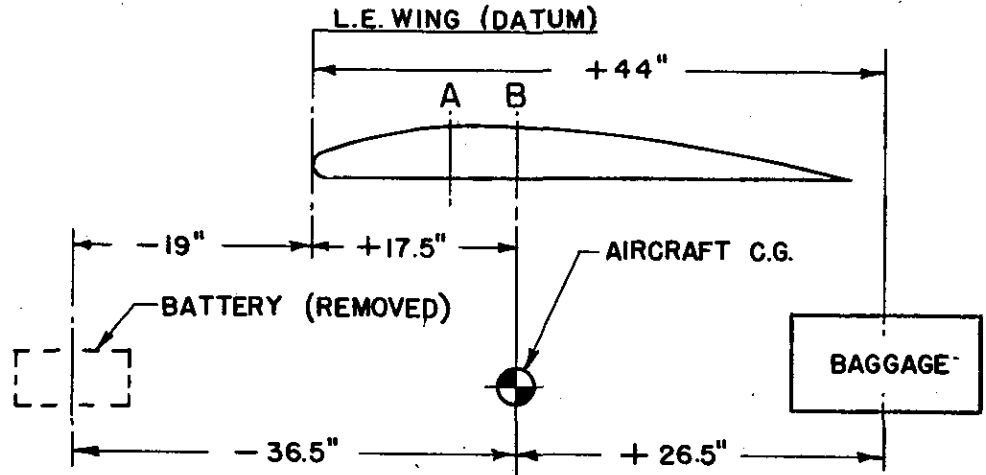

Figure 8

- Solution: (1) Assume aircraft loaded C. G. to full upon "B," the C. G. limit affected by a change of this type. (See fig. 4(a).)
- (2) By addition and subtraction refer all horizontal arms to "B," (See fig. 8.)
- (3) Moment about "B" due to removal of battery = -31 pounds \times -36.5 inches = $+1,131$ inch-pounds.
- (4) Baggage reduction necessary to prevent shift of assumed aircraft C. G. = $\frac{+1,131}{+26.5} = 42.7$ (or 43) pounds.
- (5) Placard baggage compartment for reduced capacity of $50 - 43 = 7$ pounds. (The wording of placard should be shown on report submitted.)

Case III. An electric starter is installed in Meyers OTW. (See fig. 5(a).)

Given: (Specification 2-550 (A-885)) Datum—fuselage station No. 1—

Approximately 3 inches ahead of upper wing leading edge.

Item 200 starter—15 pounds (—16) (measured).

C. G. limits—(+25.8) and (+32.7).

Baggage capacity—10 pounds (+91).

(C. G. limit affected is "A".)

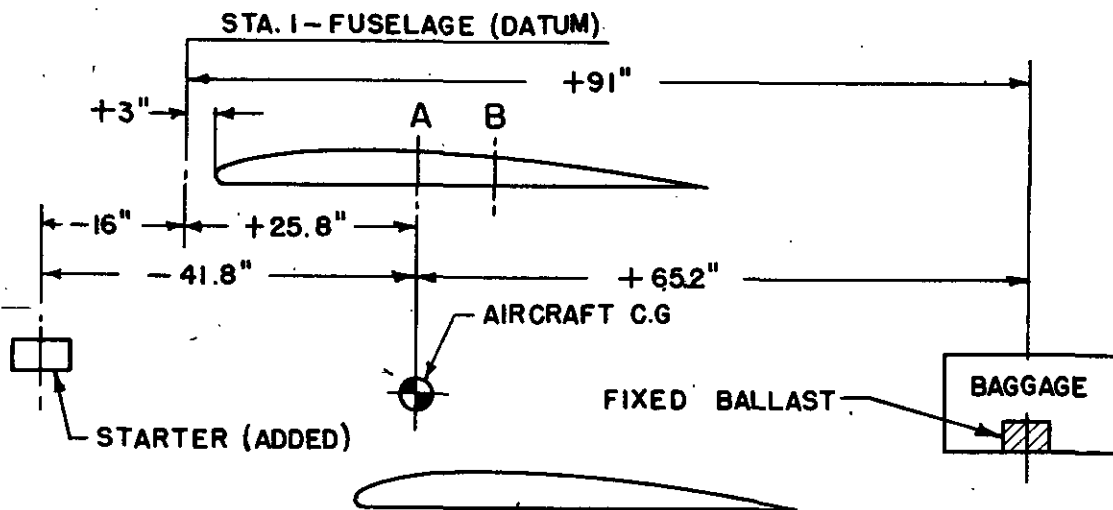

Figure 9

To find: Fixed ballast required in the baggage compartment to prevent forward movement of aircraft loaded C. G. due to starter installation.

- Solution:
- (1) Assume aircraft loaded C. G. to fall upon "A," the C. G. limit affected by a change of this type. (See fig. 5(b).)
 - (2) By addition and subtraction refer all horizontal arms to "A." (See fig. 9.)
 - (3) Moment about "A" due to addition of starter = +15 pounds \times -41.8 inches = -627 inch-pounds.
 - (4) Fixed ballast required in baggage compartment to create equal moment in opposite direction = $\frac{+627}{65.2} = 9.6$ (or 10) pounds.
 - (5) Install ballast in baggage compartment and placard as follows: "Fixed ballast 10 pounds—Not to be removed. Baggage capacity—zero."
 - (6) Revise weight empty to include the 25 pounds added. (Starter 15 pounds and ballast 10 pounds.)

Case IV. The radio receiver is removed from a Taylorcraft "A" seaplane (D-1070 floats). (See Fig. 5(b).)

Given: C. G. limits (+18.1) and (+20.4) (Specification 643, A-616).
 Item 202 Radio—9 pounds (+38).
 Tailpost at (+173) (measured).
 (C. G. limit affected is "A".)

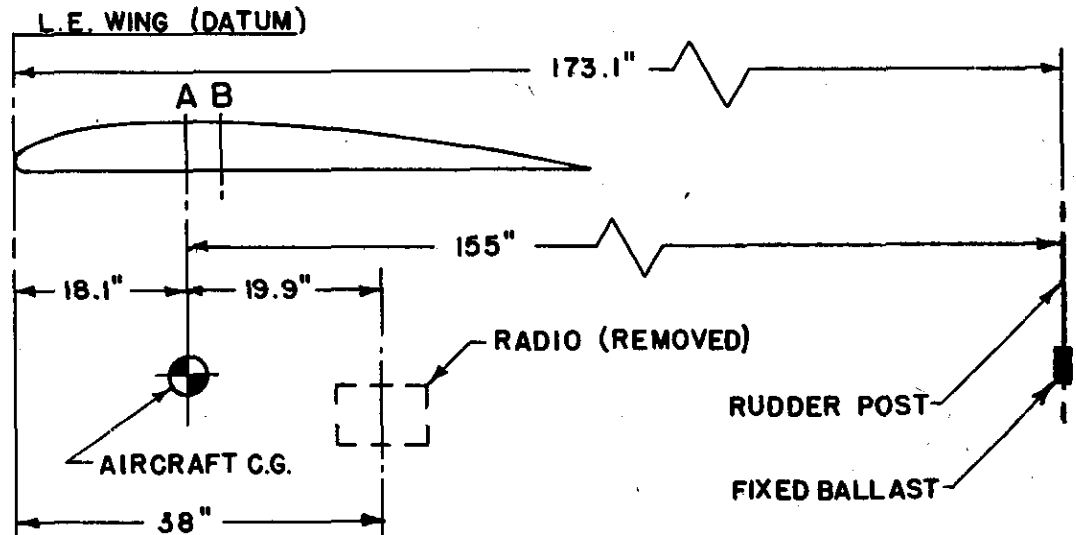

Figure 10

To find: Fixed ballast to be installed on rudder post to prevent possibility of aircraft loaded C. G. exceeding approved forward limit (A).

- Solution: (1) Compute moment about "A" due to removal of radio:
 $-9 \text{ pounds} \times (+19.9 \text{ inches}) = -179 \text{ inch-pounds.}$
 (2) Ballast required at tailpost to create equal moment in opposite direction:
 $\frac{+179}{155} = 1.1 \text{ (or 1) pound.}$
 (3) Install and placard "1 pound ballast—Do not remove."

Case V. Several items are added or removed throughout the aircraft.

Given: Weight and moment arm of each item. C. G. limits.

To find: Compensating change required to prevent possibility of the aircraft C. G. extremes exceeding the approved limits.

- Solution: (1) Obtain moment of each item about the datum listed on specification.
 (2) By addition, obtain net moment.
 (3) By addition, obtain net weight change.
 (4) Determine resultant C. G. position (inches aft of datum)

$$\text{C. G.} = \frac{\text{net moment}}{\text{net weight change}} = \frac{(2)}{(3)}$$

 (5) Consider as single change, assume aircraft C. G. to fall upon approved C. G. limit affected and proceed as in the foregoing examples.

When the necessary information is not contained in the pertinent specification (as for older models), it will be necessary to obtain such data by computation and actual measurement.

APPENDIX III
SPLICING AIRCRAFT CABLE

Aircraft cable should be spliced in accordance with the recommendations of the Civil Aeronautics Administration by using either the tuck or the wrapped and soldered splice. The kind of splice to be used in a specific case is determined by the diameter of the cable and its flexibility or nonflexibility. See CAM 18.605.

A. ARMY TUCK SPLICE.

The Army tuck splice is made in accordance with the procedure outlined in the following: The splice should have five full tucks and should be served (wrapped) with a 6-cord thread. In pounding the splice, a mallet made of fiber, wood, copper, or other non-abraiding material should be used. The anvil or surface on which the splice is pounded should be of hardwood.

In splicing loop terminals into a turnbuckle, clevis, etc., the following terms are used:

Standing wire—The measured length of wire which will be used when completed.

Bight—The loop around the thimble.

Free end—The loose end which will be opened up for splicing.

In making the splice, the first operation is to tie or clamp the cable around the thimble, leaving about 8 inches of free end with which to make the splice. With cable larger than $\frac{1}{8}$ inch or $\frac{1}{2}$ inch it is best to allow a little more free end.

Clamp the standing wire in a vise, with the free end to the left of the standing wire and away from the operator. Bend the thimble points back from the cable at an angle of about 45° to allow the tucked ends to be pulled back against the thimble.

Select the free strand lying directly under the thimble points and separate it from the rest of the free ends by inserting a marlinspike under it and spiraling the spike around the free end. The cable then should appear as in figure 1.



Fig. 1

Insert the marlinspike under the first three strands of standing cable, to the right of the thimble points. Insert the loose free strand under the three standing strands, tucking from left to right. Figure 2 will illustrate the condition of the cable at this point

1. *Separating second strand.* The second free strand to the left of the thimble points then should be separated from the others as before described. This wire should be the next to the left of the first free strand tucked. Insert the marlinspike under the first two standing strands to the right of the thimble points and tuck the loose end under these two standing strands, tucking from left to right as in figure 3.

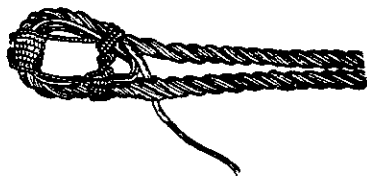

Fig. 2



Fig. 3

Take the third free strand to the left of the thimble points and separate. Insert the marlinspike under one standing strand to the right of the thimble points and tuck the loose free end under this standing strand; tuck from left to right. The cable now should appear as in figure 4.

Separate the center or core wire from the other free ends. This core wire can easily be distinguished from the outside wires by its smooth, even surface. The outside wires are waved evenly by being coiled around the center of the core wire. Tuck the center free end under the last two standing strands used and bring it out in the same opening as the second free end which was tucked. The core wire should lie between the vise and the second free end and should appear as in figure 5.

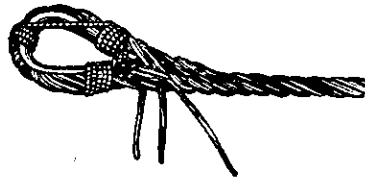

Fig. 4

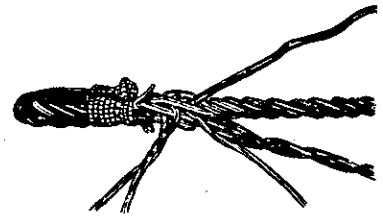

Fig. 5

Select the free strand which lies last to the left of the thimble points and separate. Insert the marlinspike from right to left under the two standing strands immediately to the left of the thimble points. Insert the loose free end from right to left under these two standing strands. This is the only place in the first round of tucks where the tuck is made from right to left. The cable now appears as in figure 6. To complete this operation, pull the free end of the last strand tucked, until the loop shown in figure 6 disappears and there is no slack in the strand.

Separate the two remaining free ends. Insert the marlinspike under the first standing strand to the left of the thimble points. Choose the free end which lies next in order of rotation to the first three wires tucked. This should be the fourth free strand to the left of the thimble points. Tuck this free strand under the lifted standing strand, tucking from left to right. Figure 7 illustrates the present condition of the splice.



Fig. 6

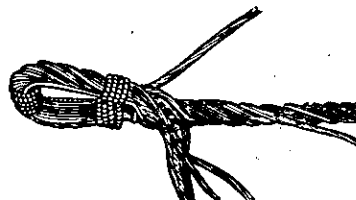

Fig. 7



Fig. 8

With the marlinspike, lift the second standing strand to the left of the thimble points. Tuck the remaining free strand under the lifted standing strand. Tuck from left to right. The cable now should appear as in figure 8.

2. *Finishing operation.* The finished condition of a splice depends considerably upon the following operation. Choose the tucking strand which lies in the opening with the center strand. Grasp it firmly in a pair of fairly heavy pliers and pull sharply

upon it several times away from the thimble. Then, keeping the strand always taut, describe a half circle with the pliers and pull steadily back into the throat of the thimble. (The throat of the thimble is the joint of the two ends lying between the four points, previously turned back at an angle of 45° .) Continue this operation completely around the standing cable until each of the tucking strands has been pulled down away from the thimble and then back against the throat. Next pull down the free center strand but do not pull it back.

In the next operation select the tucking strand to the right of the center free strand and tuck it over one standing strand and under the next standing strand. Tuck from right to left. (See fig. 9.) Continue this operation around the standing cable to the left until all six of the tucking strands have been tucked. Do not tuck the free center strand on this or any succeeding series of tucks. After tucking all six tucking strands repeat the finishing operation described in the preceding paragraph. This constitutes the second series of tucks and the cable should appear as in figure 10.

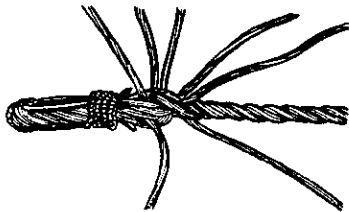

Fig. 9

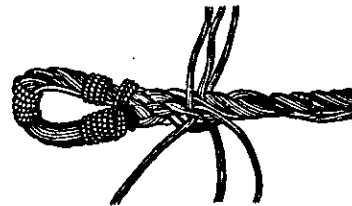

Fig. 10

The third series of tucks is made exactly in the same way as the second series and should be followed by the finishing operation previously described.

The six tucking strands are now split in half and a series of tucks is made in the same manner as that described for the full strands but using only one-half of each strand. After this operation repeat the finishing operation. (See fig. 11.)

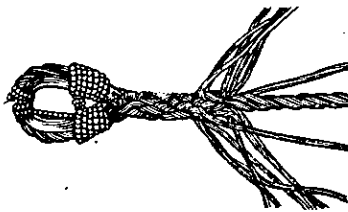

Fig. 11

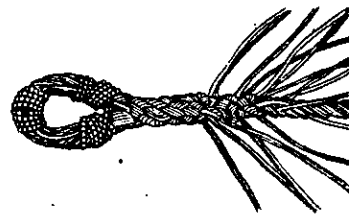

Fig. 12

The core wire or free center strand should now be cut off as close as possible to the standing cable. The six half strands which were tucked in the last operation are again halved, making them one-quarter the size of a full strand. A series of tucks is now made using six one-quarter strands and following with the finishing operation. This completes the tucking of all strands. (See fig. 12.)

3. *Hammering splice.* All that remains to be done now is to hammer the splice taut, cut off the protruding ends of the tucking strands, and serve with linen thread. A small hardwood mallet or rawhide faced hammer and a hardwood anvil should

be used to beat the splice. Starting at the thimble points (which now should be laid down upon the splice), drive the tucking strands from right to left, just as they were tucked. Roll the splice upon the anvil as it is beaten, in order that all the strands may receive an even tautness. When the splice is as taut and hard as it can be made, cut off the ends of the tucking strands as close to the splice as practicable. Pound the taper slightly to lay the sheared ends and then serve with six-cord linen thread.

In applying the serving, start about $\frac{1}{4}$ of an inch below the end of the taper and wrap smoothly up the taper until all of the sheared ends are covered. Then take five or six loose coils over thumb or finger and insert the end of the serving cord through the loose coils from the thimble and toward the taper. Now wrap the loose coils firmly over the inserted end and pull up any slack by drawing the inserted end down toward the taper. Cut off close to the serving and beat it lightly with the mallet to smooth it down. Two coats of shellac should be applied to the serving to make it as nearly waterproof as possible. The finished splice should appear as in figure 13.



Fig. 13

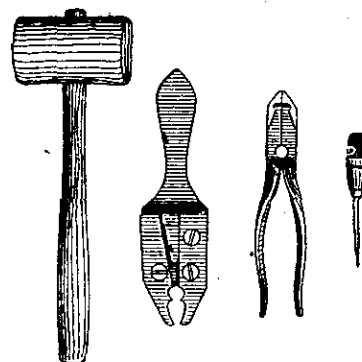

Fig. 14

The tools shown in figure 14, which include a marlinspike, side-cutting pliers, splicing clamp, and mallet, are recommended for use in splicing terminals of flexible cable.

B. NAVY TUCK SPLICE.

In making the tuck splice in accordance with Navy specifications, the following method is used:

Before the cable is cut it shall be thoroughly soldered for 2 or 3 inches to prevent any slipping of the wires after cutting. The flux used in this soldering shall be stearic acid rosin. Sal ammoniac or other compounds having a corrosive effect are not acceptable either as a flux or for cleaning the soldering tools.

The cable shall be cut to the proper length by mechanical means only. The use of oxyacetylene torches in any manner is not permitted.

The serving cord shall be a seven-strand linen machine cord or an equivalent cotton cord. In forming the splice, the cable is bent securely around the thimble and clamped, the tip of the thimble having previously been bent back to permit a tight splice. The length of the free end of the cable from point of thimble should be 2 or 3 inches longer than required to produce the number of tucks needed.

After the cable is securely clamped in the thimble, the strands are to be broken apart where soldered at the ends and separated back to the point of the thimble.

A small wood, fiber, or copper mallet is to be used in pounding the splice. The anvil on which it is pounded shall be of hardwood.

1. *Commencing splice.* In making the splice, take the first free strand on the right-hand side and tuck it under the first strand which is nearest the point of the thimble on the right. Take the free strand directly underneath the first strand and tuck

it through the center of the cable. Three longitudinal strands should then lie each side of this tucked strand. Then insert the core wire directly over the same strand so that these two strands will come out in the same position. Then take the free strand on the extreme left and tuck it underneath the strand which is nearest the point of the thimble on the left. Next, tuck the free strand which runs parallel to the first free strand on the right side under the longitudinal strand which had been tucked. Five strands should now have been tucked and two remain free. Then, take the free strand on the left and tuck it toward the right underneath the remaining longitudinal strand. This free strand must come out directly above the second free strand which has been tucked. Then take the remaining free strand which is located on the right and tuck it toward the left underneath the same longitudinal strand. At this point a free strand will be between each longitudinal strand with the exception of the core wire which comes out with the center strand. The whole of the preceding operation is called the first tuck. At this point two free strands which cross directly above one another at the eye will be prominent. These strands should be pounded down to tighten splice to the thimble.

For the second tuck, take the free strand on the opposite side of the splice which comes out to the right of the core strand and tuck it to the left over the longitudinal strand and underneath the next longitudinal strand. This binds in the core strand to the center of the splice. Repeat this operation with the all the remaining free strands to the left. The tucks now should again be pounded down to make the splice tight and symmetrical.

For the third tuck, take the strand which comes out to the right of the core strand and tuck it toward the left over the first longitudinal strand and under the next longitudinal strand. This operation will bind in the core strand. Repeat this operation with all the remaining free strands to the left. The core wire is then cut off close to the splice and the tucks are pounded as previously directed to tighten the splice and to make it symmetrical.

2. *Reducing strands.* All free strands now are reduced one-third but should not be cut until the following complete tuck has been made by the six remaining two-thirds strands as before directed for the full strand. This completes the fourth tuck.

The free untucked one-third strands should not be cut off close to the splice. The splice again is pounded as previously directed. The free strands should now be halved and tucked to the left, allowing the remaining one-third strands to be free, as indicated before. The six remaining one-third strands then are cut off close to the splice.

At this time the five tucks will have been completed and now should be pounded as before and the remaining one-third tucked strand cut off close to the splice. The complete splice then should then be turned away from the operator while it is being pounded so that the free strands are drawn up tight into the longitudinal strands. The thimble points should then be carefully flattened to the splice.

Cable $\frac{1}{4}$ inch in diameter and larger should be spliced with six tucks in place of five to insure strength and proportion. In this case four complete tucks are made in place of three before starting to taper.

In order to serve the splice, place the end of the serving cord on the cable $\frac{1}{4}$ inch above the fifth tuck. Carry the cord on the cable toward the thimble to a point midway between the thimble and the third tuck. From this point, the cord should then be tightly and closely served around the cable, covering all tucks to a distance on the unspliced portion equal to the diameter of the wire. The cord then is snubbed by inserting the end under four convolutions of the serving and the convolutions drawn tightly down on the cable. The serving is to be given two generous coats of shellac.

C. ARMY WRAPPED AND SOLDERED SPLICE.

In making the wrapped and soldered splice according to the Army method, wrapping wire of soft-annealed steel thoroughly and smoothly tinned by means of the hot process is used.

The soldering flux shall be stearic acid or a suitable mixture of stearic acid and rosin. Rosin dissolved in alcohol or other solvent approved by the Army Air Corps also may be used.

The cable is cut to length only by mechanical means, the use of oxyacetylene torch in any manner not being permitted.

The wrapping wire shall be applied either by machine or hand, under constant tension. All terminals shall be thoroughly cleaned before soldering by immersing in the flux.

The terminals shall be smoothly soldered. The space between the wrapping wire and the cable shall be completely filled with solder. Abrasive wheels or files are not to be used for removing solder.

D. NAVY WRAPPED AND SOLDERED SPLICE.

The Navy method of making the wrapped and soldered splice is as follows:

The serving or wrapping wire shall be of commercial soft-annealed steel wire or commercial soft iron wire, thoroughly and smoothly tinned or galvanized.

The solder shall be half-and-half tin and lead conforming to Navy specifications. The melting point of this solder varies from 320° to 390° F., and the tensile strength is approximately 5,700 pounds per square inch.

Solder flux shall be a compound of stearic acid (there shall be no mineral acid present) and rosin, with a composition of 25 to 50 percent stearic acid and 75 to 50 percent rosin. A warming gluepot to keep the flux in fluid state is desirable.

Before the cable is cut the wires are soldered or welded together to prevent slipping. The preferable process is to tin and solder the cable thoroughly for 2 or 3 inches by placing in a solder trough, finishing smooth with a soldering tool. The cable may be cut diagonally to conform to the required taper finish.

After being soldered and cut the cable is securely bent around the proper size thimble and clamped, taking care that the cables lie close and flat and that the taper end for finish lies on the outside. If it is necessary to trim the taper at this point in the process, it is preferable that it be done by nipping, but grinding is permissible, provided a steel guard at least 3 inches long and $\frac{1}{32}$ inch thick is placed between the taper end and the main cable during the operation, and that the heat generated from the grinding does not melt the solder and loosen the wires.

1. *Serving splice.* Serving may be done by hand or machine, but in either case each serving convolution must touch the adjoining one and be pulled tightly against the cable, with spaces for permitting a free flow of solder, and inspection.

Care must be exercised to prevent drawing of the temper of any cable wires by excessive temperature or duration of applied heat. The flux used in this soldering shall be stearic acid and rosin. The use of sal ammoniac or other compounds having a corrosive effect is not permitted either as a flux or for cleaning the soldering tools.

Soldering is accomplished by immersing the terminal alternately in the flux and in the solder bath, repeating the operation until thorough tinning and filling with solder under the serving wire and thimble is obtained. The temperature of the solder bath and place where terminal is withdrawn shall not be above 450° F. A soldering iron may be used in the final operation to give a secure and good-appearing terminal. Care must be taken that the solder completely fills the space under the serving wire and thimble. A slightly hollowed cast-iron block to support the splice during soldering may help in securing the best results. The use of abrasive wheels or files for removing excess solder is not permissible.

As an alternative process for making terminals for nonflexible cable, the oxyacetylene cutting method and the presoldering method (soldering before wrapping) are

permitted, but only on the following conditions: (1) That the process of cutting securely welds all wires together; (2) that the annealing of the cable does not extend more than one cable diameter from the end; (3) that no filing be permitted either before or after soldering; (4) for protection during the operation of grinding the tapered end of the cable, a steel guard at least 3 inches in length and $\frac{1}{2}$ inch thick shall be placed between the taper and the main cable; (5) the heat from grinding shall not draw the temper of the cable.

E. ROEBLING CABLE SPLICING METHOD.

In addition to the Army and Navy methods described above, the Roebling method of splicing flexible aircraft cable, described in the following, is also acceptable to the Civil Aeronautics Administration for use on certificated aircraft.

This type of splice differs essentially from the Army and Navy tuck splice, in that the tucks are made round and round the same strand, while in the Army and Navy methods the tucks are made over and under adjacent strands. Each strand is given five whole tucks, and the completed splice is wrapped with linen cord and shellacked.

The tools to be used in making the Roebling splice consist of two wooden mallets, a spike, a serving iron, knife, and nippers, and the procedure is as follows:

Measure off 2 to 4 feet from the end of the cable, depending on the size of the cable, and bend it at that point. Lay the proper size thimble into the bend and clamp in a splicing vise with the loose end of the cable at the right when looking toward the vise.

Unlay the cable back to the thimble, serve ends of strands with fine annealed wire, bend four strands to the right and two to the left, and cut the center wire or core off close to the thimble.

Untwist the lay of the cable somewhat, then drive the spike under the two top strands of the main part of the cable, and stick the strand lying on top (that is, under the point of the thimble) through the opening. The spike should be driven from right to left and the strand stuck through in the same direction. To make this clearer, a section of the cable and the loose ends are shown, the strands in the former being numbered 1 to 6 and in the latter a to f (fig. 15). The first step, then, as stated, is to drive the spike in between 1 and 2 and out between 6 and 5 (fig. 16) and stick a through this. Next pull the strand up tight and jam it back by twisting the spike up along the lay toward the thimble.

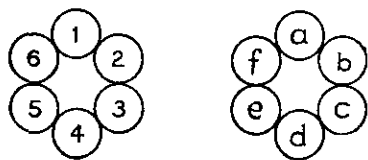

Fig. 15

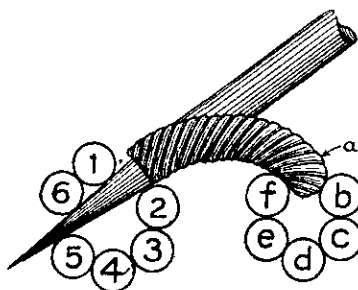

Fig. 16

1. *Tucking ends.* Then tuck in the other ends in the following manner: Follow strand around to where it lies on the bottom of the cable and drive the spike under it (that is, between 1 and 6 and 1 and 2), from the right (fig. 17), and stick end b through from the left, bringing it over the cable. Twist the spike back along the lay toward the thimble, after having pulled the end up tight, until the strand can be worked up no further. Next, drive the spike from the right under 2 where it is at the bottom of the cable, stick end c through from the left, and work back as before; and so on, d under 3, e under 4, f under 5.

All the ends having thus been tucked whole once, they are all tucked whole a second time. This second tucking consists merely in wrapping each end once around the strand from under which it comes out. Thus, a lies under 1 and 6 as a result of the first tuck just described (fig. 16). Lift 6 by means of spike (fig. 18), bring a around and back under 6, and pull up tight. B lies under 1 and is wrapped once around in the same way, and so on for c, d, e, and f.

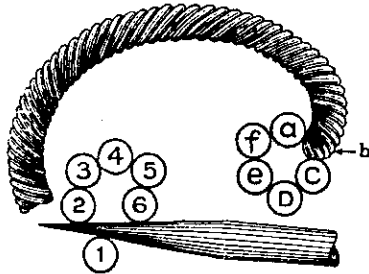

Fig. 17

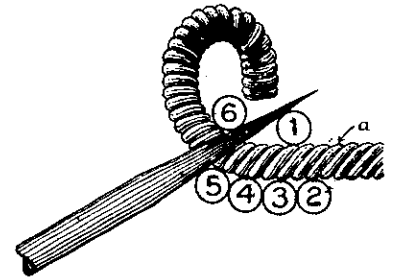

Fig. 18

The operations just described should be continued until each strand has been given five whole tucks. After the tucks are completed the ends of the strands are cut short, the splice is hammered lightly, and served with either 6- or 7-cord linen thread, or its equivalent cotton thread. The serving should start from a short distance beyond the end of the splice and end well up to the thimble points. This serving is then given two coats of shellac.

APPENDIX IV--FORMS

Form 337 (ACA 18-1)
(Rev. 6-1-41)

UNITED STATES OF AMERICA
DEPARTMENT OF COMMERCE
CIVIL AERONAUTICS ADMINISTRATION
WASHINGTON

Classification	Nature of work performed	
	Major repair	Major alteration
Aircraft.....
Engine.....
Propeller.....
Instrument.....

(To be filled in by inspector)	
After accident of	(Date)
Approved	
Disapproved	
Forwarded for engineering approval. (Submit complete details.)	
Date	
Inspector	

REPAIR AND ALTERATION FORM

AIRCRAFT—ENGINES—PROPELLERS—INSTRUMENTS

Aircraft Identification Mark No.

Owner's name

Owner's address

Aircraft manufacturer and model

Engine manufacturer and model*

Propeller manufacturer and model*

Propeller blade model*

Propeller hub model*

Serial No.

Serial No.

Serial No.

Serial No.

Serial No.

*To be filled in only for unit repaired or altered.

REPAIR OR ALTERATION AGENCY

..... Manufacturer. Approved repair station No. Certif. mechanic.

Agency's name and address

Date of repair or alteration

The following work has been accomplished in accordance with Part 18, Civil Air Regulations.
(For recommended practice refer to CAM 18.)

[If blank space is insufficient for clear presentation, attach separate pages (8" x 10 1/2" or multiples thereof) bearing aircraft identification mark.]

SUPERVISING MECHANIC'S CERTIFICATE

----- certifies that the foregoing statements are true of his own knowledge.

(Date)

(Mechanic's signature)

Mechanic's Certificate No. -----
(Rating)

Form ACA 309
(Rev. 5-1-40)

Page 5

REPAIRS AND ALTERATIONS

(Identification mark)

Record herein all major repairs and major alterations as well as those classed as minor when accomplished by a certificated repair station or the original manufacturer. (See "Maintenance, Repair and Alteration," CAA Manual 18.)

Details of repairs or alterations shall be entered below by the agency making or supervising same, including the signature of such person in the appropriate space. Entries shall be with typewriter or in ink.

The original of the "Repair and Alteration Form" shall be attached hereto by the agency responsible for repairs or alterations, and will be picked up and forwarded by the inspector for the Authority when he approves the repairs or alterations.

The inspector endorsing an entry in item 3 of this sheet shall attach an additional sheet 5. All such sheets will become a permanent part of this Operation Record.

1. Repair and Alteration Form _____ (Dated) _____
 covers repairs or alterations by _____ and
 supervised or released by _____ (Agency name and number)
 and described as follows: _____ (Signature of official or mechanic. Title or rating and number)

Repairs were of damages incurred in accident of _____, at _____
(Date) (Place)

Approved by _____
(Inspector's signature)

2. Repair and Alteration Form _____ (Dated) _____
 covers repairs or alterations by _____ and
 supervised or released by _____ (Agency name and number)
 and described as follows: _____ (Signature of official or mechanic. Title or rating and number)

Repairs were of damages incurred in accident of _____, at _____
(Date) (Place)

Approved by _____
(Inspector's signature)

3. Repair and Alteration Form

(Dated)

covers repairs or alterations by _____ and

(Agency name and number)

supervised or released by _____

(Signature of official or mechanic. Title or rating and number)

and described as follows: _____

Repairs were of damages incurred in accident of _____, at _____

(Date)

(Place)

Approved by _____

(Inspector's signature)

4. Repair and Alteration Form

(Dated)

covers repairs or alterations by _____ and

(Agency name and number)

supervised or released by _____

(Signature of official or mechanic. Title or rating and number)

and described as follows: _____

Repairs were of damages incurred in accident of _____, at _____

(Date)

(Place)

Approved by _____

(Inspector's signature)

5. Repair and Alteration Form

(Dated)

covers repairs or alterations by _____ and

(Agency name and number)

supervised or released by _____

(Signature of official or mechanic. Title or rating and number)

and described as follows: _____

Repairs were of damages incurred in accident of _____, at _____

(Date)

(Place)

Approved by _____

(Inspector's signature)

Form ACA 455
(Rev. 9-1-40)

UNITED STATES OF AMERICA
DEPARTMENT OF COMMERCE
ADMINISTRATOR OF CIVIL AERONAUTICS
WASHINGTON, D. C.

POWERPLANT FAILURE REPORT

Submit as a supplement to Aircraft Accident Report (Form 453 or 454) when an accident involves a failure of the engine, propeller, or any part of the powerplant installation.

This form should be used also by owners, operators, pilots, mechanics, inspectors, and investigators to report powerplant failures within their positive knowledge which affect safety but have not resulted in accidents.

Form 456 should be used for reporting failures involving the airplane structure.

I. Location and date of failure _____
(City) (State) (Date) (Hour)

II. Pilot _____
(Full name) (Address) (Certificate number and ratings)

III. Aircraft _____
(Manufacturer and model) (Manufacturer's serial number) (Identification mark)

IV. Registered owner of aircraft _____
(Name) (Address)

V. Engine _____
(Manufacturer and model) (Serial numbers)

VI. Did an accident occur? _____ Was it reported on Accident Form 453 or 454? _____
(Check which)

VII. Failure occurred on ground , in take-off , climb , cruising , or landing .

VIII. If in take-off or in flight, did an immediate forced landing result? _____
(Check which)

IX. Landing place was: Established airport , intermediate field , undeveloped field .

X. Describe failure in detail. (Include pertinent events before failure, altitude at time of failure, and when possible use sketches or photographs marked to show location and origin of failure. If failure involves other than factory-built parts, describe parts.) _____

(Sketch location of failure on part)

- XI. If failure concerns specific part, answer following:
1. Manufacturer of part _____
 2. Name and manufacturer's No. _____
 3. Service hours of part _____
 4. Last overhaul or inspection _____
 5. Who made inspection? _____

XII. Probable cause and recommendations to prevent a future failure:

(Answer pertinent questions on back)

XIII. If failure in engine structure, answer following:

- 1. Date engine first used ----- Total engine hours -----
- 2. Date last overhaul ----- Hours since overhaul -----
- 3. Who made overhaul, and describe extent -----
- 4. Propeller used on engine ----- Gasoline used -----

XIV. If failure in ignition system, answer following:

- 1. Make and model of magnetos or distributors -----
- 2. Make and model of spark plugs -----
- 3. Was engine equipped with single or dual ignition? -----
- 4. Date of last overhaul of each and condition of system -----

XV. If failure in lubrication system, answer following:

- 1. Name and grade of oil ----- Hours of use -----
- 2. Date of overhaul and condition of system -----

XVI. If failure in fuel system, answer following:

- 1. Name and octane number of fuel -----
- 2. When and where was fuel purchased? -----
- 3. Model of carburetor ----- Jet sizes -----
- 4. Describe changes from fuel system supplied by manufacturer -----
- 5. Date and hours since entire system was inspected and drained of residue -----
- 6. Who made this inspection? -----
- 7. Which tanks turned on at time of failure? -----
- 8. Quantity of fuel in each tank turned on -----
- 9. Describe exact location and extent of any water, sediment, or stoppage found in system (includes tanks, sumps, valves, lines, fittings, strainers, carburetor bowl) -----

XVII. If failure due to ice formation in carburetor air intake system, answer following:

- 1. Outside air temperature at the altitude and time icing occurred? -----
- 2. Describe any high humidity, rain or snow conditions (include dew point or relative humidity if possible) -----
- 3. Describe use of carburetor heat control and state when full heat was first used -----

XVIII. If propeller failure, answer following:

- 1. Manufacturer and name of propeller -----
- 2. Model of propeller ----- Blades ----- Hub -----
- 3. Serial number of propeller ----- Blades ----- Hub -----
- 4. Number of blades ----- Diameter ----- Pitch -----
- 5. Date propeller was first used ----- Total hours -----
- 6. Hours since last detailed inspection ----- Describe inspection -----
- 7. Names, models, and hours of operation on other engines and aircraft -----
- 8. If propeller has had previous accident, give full particulars including description of repair and by whom made -----
- 9. Hours of operation in salt air ----- Salt spray -----
- 10. If a tip failure, describe condition of under surface of blade near tip -----

(Signature) -----
(Owner, operator, pilot, mechanic, inspector or investigator)

(Address) -----

Date of this report -----

Form ACA 456
(Rev. 9-1-40)

UNITED STATES OF AMERICA
DEPARTMENT OF COMMERCE
ADMINISTRATOR OF CIVIL AERONAUTICS
WASHINGTON, D. C.

AIRCRAFT STRUCTURAL FAILURE AND DEFECTS REPORT

Submit as a supplement to Aircraft Accident Report (Form 453 or 454) when an accident involves a failure of the airplane structure or any part thereof.

This form should be used also by owners, operators, pilots, mechanics, inspectors and investigators to report airplane structural failures within their positive knowledge which affect safety but have not resulted in accidents. Form 455 should be used for reporting failures involving the powerplant installation.

- I. Location and date of failure -----
(City) (State) (Date) (Hour)
- II. Pilot -----
(Full name) (Address) (Certificate number and ratings)
- III. Aircraft -----
(Manufacturer and model) (Manufacturer's serial number) (Identification mark)
- IV. Registered owner of aircraft -----
(Name) (Address)
- V. Did an accident occur? ----- Was it reported on Accident Form 453 or 454? -----
- VI. Check components involved:
Wing ----- Wing bracing ----- Landing gear ----- Control surfaces -----
Control system ----- Fuselage ----- Engine mount ----- Hull -----
Fitting ----- Appliance -----
- VII. DESCRIPTION: (Include pertinent events prior to failure *and if other than factory-built parts*, describe same. Complete details, including sketches or photographs properly marked to show location of failure, should be provided. In case of fitting failure, submit part, if possible, to the nearest Civil Aeronautics office. Parts submitted for inspection should be plainly tagged, giving identification number of aircraft from which taken and owner's desires as to whether or not the part should be returned to him.)
- VIII. Approximate hours of service on part prior to failure -----
- IX. Condition of aircraft relative to maintenance: Excellent ----- Fair ----- Poor -----
- X. Probable cause and recommendations to prevent a recurrence:

Date of this report ----- (Signature) -----
(Owner, operator, pilot, mechanic, inspector or investigator)

(Address)

